



**Rail Telecommunications (RT);
Next Generation Communication System;
Radio performance simulations and
evaluations in rail environment;
Part 1: Long Term Evolution (LTE)**

Reference

RTR/RT-0051

Keywords

FRMCS, LTE, radio, railways, simulation

ETSI

650 Route des Lucioles
F-06921 Sophia Antipolis Cedex - FRANCE

Tel.: +33 4 92 94 42 00 Fax: +33 4 93 65 47 16

Siret N° 348 623 562 00017 - NAF 742 C
Association à but non lucratif enregistrée à la
Sous-Préfecture de Grasse (06) N° 7803/88

Important notice

The present document can be downloaded from:

<http://www.etsi.org/standards-search>

The present document may be made available in electronic versions and/or in print. The content of any electronic and/or print versions of the present document shall not be modified without the prior written authorization of ETSI. In case of any existing or perceived difference in contents between such versions and/or in print, the prevailing version of an ETSI deliverable is the one made publicly available in PDF format at www.etsi.org/deliver.

Users of the present document should be aware that the document may be subject to revision or change of status.

Information on the current status of this and other ETSI documents is available at

<https://portal.etsi.org/TB/ETSIDeliverableStatus.aspx>

If you find errors in the present document, please send your comment to one of the following services:

<https://portal.etsi.org/People/CommiteeSupportStaff.aspx>

Copyright Notification

No part may be reproduced or utilized in any form or by any means, electronic or mechanical, including photocopying and microfilm except as authorized by written permission of ETSI.

The content of the PDF version shall not be modified without the written authorization of ETSI.

The copyright and the foregoing restriction extend to reproduction in all media.

© ETSI 2020.

All rights reserved.

DECT™, **PLUGTESTS™**, **UMTS™** and the ETSI logo are trademarks of ETSI registered for the benefit of its Members.

3GPP™ and **LTE™** are trademarks of ETSI registered for the benefit of its Members and of the 3GPP Organizational Partners.

oneM2M™ logo is a trademark of ETSI registered for the benefit of its Members and of the oneM2M Partners.

GSM® and the GSM logo are trademarks registered and owned by the GSM Association.

Contents

| | |
|---|----|
| Intellectual Property Rights | 5 |
| Foreword..... | 5 |
| Modal verbs terminology..... | 5 |
| Executive summary | 5 |
| Introduction | 6 |
| 1 Scope | 7 |
| 2 References | 7 |
| 2.1 Normative references | 7 |
| 2.2 Informative references..... | 7 |
| 3 Definition of terms, symbols and abbreviations..... | 8 |
| 3.1 Terms..... | 8 |
| 3.2 Symbols..... | 8 |
| 3.3 Abbreviations | 8 |
| 4 Assumptions and parameters for simulations and evaluations..... | 10 |
| 4.1 Introduction | 10 |
| 4.2 Simulation tools..... | 10 |
| 4.3 Scenarios | 11 |
| 4.4 Bandwidth and transmit power..... | 12 |
| 4.4.1 Bandwidths | 12 |
| 4.4.1.1 900 MHz band..... | 12 |
| 4.4.1.2 1 900 MHz band..... | 12 |
| 4.4.2 Transmit powers | 13 |
| 4.4.2.1 900 MHz band..... | 13 |
| 4.4.2.2 1 900 MHz band..... | 13 |
| 4.5 Antenna diagrams..... | 14 |
| 4.5.1 Antenna diagrams at the base station..... | 14 |
| 4.5.1.1 For 900 MHz band | 14 |
| 4.5.1.2 For 1 900 MHz band | 14 |
| 4.5.2 Antenna diagrams at the UE | 14 |
| 4.6 Radio propagation aspects..... | 14 |
| 4.6.1 Radio propagation model..... | 14 |
| 4.6.2 Conclusion | 16 |
| 4.7 Frequency reuse scheme..... | 16 |
| 4.8 Summary | 16 |
| 4.9 Outcomes of the simulations | 18 |
| 5 Simulation results..... | 18 |
| 5.1 Results set 1..... | 18 |
| 5.1.1 Description..... | 18 |
| 5.1.2 Specific assumptions and parameters | 20 |
| 5.1.2.0 Frequency reuse scheme | 20 |
| 5.1.2.1 FDD 900 MHz band..... | 20 |
| 5.1.2.2 TDD 1 900 MHz band..... | 22 |
| 5.1.3 Results | 22 |
| 5.1.3.1 Introduction..... | 22 |
| 5.1.3.2 Results for 900 MHz band | 23 |
| 5.1.3.2.1 Results at 1,4 MHz - First round | 23 |
| 5.1.3.2.2 Results at 1,4 MHz - Second round..... | 25 |
| 5.1.3.2.3 Results at 3 MHz | 27 |
| 5.1.3.2.4 Results at 5 MHz | 30 |
| 5.1.3.3 Results for 1 900 MHz band | 34 |
| 5.1.4 Notes and remarks | 40 |
| 5.1.4.1 Notes and remarks on first round of results (900 MHz band)..... | 40 |

| | | |
|-----------------|--|------------|
| 5.1.4.2 | Notes and remarks on second round of results (900 MHz band) | 41 |
| 5.1.4.3 | Notes and remarks for results in 1 900 MHz band | 43 |
| 5.2 | Results set 2 (900 MHz band) | 43 |
| 5.2.1 | Description | 43 |
| 5.2.1.1 | Lab setup high level description | 43 |
| 5.2.1.2 | Lab setup: 3GPP RF Channel Emulator | 44 |
| 5.2.1.3 | Lab setup: FRMCS Traffic Generator and Analyser | 45 |
| 5.2.2 | Specific assumptions and parameters | 45 |
| 5.2.3 | Results | 45 |
| 5.2.4 | Notes and remarks | 45 |
| 5.3 | Results set 3 (900 MHz band) | 45 |
| 5.3.1 | Description | 45 |
| 5.3.2 | Specific assumptions and parameters | 46 |
| 5.3.2.1 | Common assumptions | 46 |
| 5.3.2.2 | Hilly channel model | 47 |
| 5.3.2.3 | Rural channel model | 47 |
| 5.3.3 | Results | 49 |
| 5.3.3.1 | Hilly channel model | 49 |
| 5.3.3.2 | Rural channel model | 49 |
| 5.3.4 | Notes and remarks | 51 |
| 6 | Results evaluation | 52 |
| 6.1 | Analysis at 900 MHz | 52 |
| 6.1.1 | General | 52 |
| 6.1.2 | Overhead analysis | 52 |
| 6.1.2.1 | General | 52 |
| 6.1.2.2 | IP stack, PDCP and RLC overhead | 52 |
| 6.1.2.3 | Physical layer overhead | 53 |
| 6.1.2.4 | Link-level comparison | 53 |
| 6.1.3 | Train speed impact | 54 |
| 6.1.4 | Neighbouring cells interference impact | 56 |
| 6.1.5 | HARQ impact estimation | 56 |
| 6.1.6 | Results comparison and <i>net throughputs</i> at hand-over point | 58 |
| 6.2 | Analysis at 1 900 MHz | 59 |
| 6.2.1 | Overhead analysis | 59 |
| 6.2.2 | Train speed impact | 59 |
| 6.2.3 | MIMO impact | 60 |
| 6.2.4 | <i>Net throughput</i> at cell edge | 60 |
| 7 | Conclusion | 61 |
| Annex A: | Theoretical peak throughput for LTE | 63 |
| Annex B: | Throughput curves for simulation results set 1 | 64 |
| B.1 | First round of simulations (900 MHz) | 64 |
| B.2 | Second round of simulations (900 MHz) | 73 |
| Annex C: | Data Throughput Measurements for results set 3 | 121 |
| Annex D: | Antenna diagrams | 123 |
| Annex E: | Propagation models | 128 |
| Annex F: | Change history | 129 |
| History | | 130 |

Intellectual Property Rights

Essential patents

IPRs essential or potentially essential to normative deliverables may have been declared to ETSI. The information pertaining to these essential IPRs, if any, is publicly available for **ETSI members and non-members**, and can be found in ETSI SR 000 314: "*Intellectual Property Rights (IPRs); Essential, or potentially Essential, IPRs notified to ETSI in respect of ETSI standards*", which is available from the ETSI Secretariat. Latest updates are available on the ETSI Web server (<https://ipr.etsi.org/>).

Pursuant to the ETSI IPR Policy, no investigation, including IPR searches, has been carried out by ETSI. No guarantee can be given as to the existence of other IPRs not referenced in ETSI SR 000 314 (or the updates on the ETSI Web server) which are, or may be, or may become, essential to the present document.

Trademarks

The present document may include trademarks and/or tradenames which are asserted and/or registered by their owners. ETSI claims no ownership of these except for any which are indicated as being the property of ETSI, and conveys no right to use or reproduce any trademark and/or tradename. Mention of those trademarks in the present document does not constitute an endorsement by ETSI of products, services or organizations associated with those trademarks.

Foreword

This Technical Report (TR) has been produced by ETSI Technical Committee Railway Telecommunications (RT).

The present document is part 1 of a multi-part deliverable covering radio performance simulations and evaluations in rail environment, as identified below:

Part 1: "Long Term Evolution (LTE)";

Part 2: "New Radio (NR)".

Modal verbs terminology

In the present document "**should**", "**should not**", "**may**", "**need not**", "**will**", "**will not**", "**can**" and "**cannot**" are to be interpreted as described in clause 3.2 of the [ETSI Drafting Rules](#) (Verbal forms for the expression of provisions).

"**must**" and "**must not**" are **NOT** allowed in ETSI deliverables except when used in direct citation.

Executive summary

In order to assess 3GPP LTE radio performance in a rail environment, three scenarios have been defined: Rural, Hilly and Urban, representing various radio conditions typical to rail environment. Each scenario has been defined with its radio parameters, load condition and train speeds.

UIC and E-UIC spectrum bands have been assumed, with bandwidth of 1,4 MHz, 3 MHz and 5 MHz, corresponding to possible deployments with LTE and GSM-R co-existence and deployment with a standalone LTE.

Three different studies are described. One is based on simulation with a software chain tool using a Monte-Carlo statistical approach, including multiple cells in a linear deployment along the track. The two others are based on laboratory radio test bench, featuring hardware communication devices and wireless channel emulators, but not taking into account multiple cells interferences.

The present document includes results from software chain tool study and from one of the two laboratory radio test bench study.

The impact of using a TDD mode in other frequency bands will need to be added to the present document.

Introduction

3GPP LTE radio access is one candidate for the radio access technology to be used for the Future Rail Mobile Communications System (FRMCS). In the present document, the term FRMCS refers -unless stated otherwise- to the radio part of the communication system.

Radio performance evaluation of an LTE system could be done by simulation, through software and processing resources only, or through a test bench incorporating pieces of equipment emulating parts of the chain, e.g. the RF. In both cases, it is important to align the parameters and the assumptions made in the simulation and in the evaluation chain to be able to reflect better a deployment in a rail environment, and to better compare and understand the simulation and the evaluation results.

1 Scope

The present document:

- Defines the simulation parameters relevant to rail environment relating to 3GPP LTE radio performance. This includes in particular operating frequency bands, bandwidths, deployment scenario (inter-site distance), and antenna characteristics, transmit powers and channel models, along with relevant metrics to be evaluated.
- Collects and analyse the simulation results of an LTE system in the rail environment operating in the 900 MHz frequency band (UIC and E-UIC bands).
- Collects and analyse the simulation results of an LTE system in the rail environment operating in a 1 900 MHz frequency band.
- Identifies limitations of an LTE system in the rail environment.

2 References

2.1 Normative references

Normative references are not applicable in the present document.

2.2 Informative references

References are either specific (identified by date of publication and/or edition number or version number) or non-specific. For specific references, only the cited version applies. For non-specific references, the latest version of the referenced document (including any amendments) applies.

NOTE: While any hyperlinks included in this clause were valid at the time of publication ETSI cannot guarantee their long term validity.

The following referenced documents are not necessary for the application of the present document but they assist the user with regard to a particular subject area.

- [i.1] ETSI TS 145 005 (V14.4.0) (04-2018): "Digital cellular telecommunications system (Phase 2+) (GSM); GSM/EDGE Radio transmission and reception (3GPP TS 45.005 version 14.4.0 Release 14)".
- [i.2] ETSI TS 136 104 (V14.7.0) (04-2018): "LTE; Evolved Universal Terrestrial Radio Access (E-UTRA); Base Station (BS) radio transmission and reception (3GPP TS 36.104 version 14.7.0 Release 14)".
- [i.3] ETSI TS 136 101 (V14.7.0) (04-2018): "LTE; Evolved Universal Terrestrial Radio Access (E-UTRA); User Equipment (UE) radio transmission and reception (3GPP TS 36.101 version 14.7.0 Release 14)".
- [i.4] Recommendation ITU-R M.2135-1 (12-2009): "Guidelines for evaluation of radio interface technologies for IMT advanced".
- [i.5] IST-4-027756 Winner II D1.1.2 V1.2 Winner II Part I: "Channel Models", European Commission, Deliverable IST-WINNER D.
- [i.6] Ikuno, J. Colom, Martin Wrulich, and Markus Rupp.: "Performance and modelling of LTE H-ARQ." Proc. International ITG Workshop on Smart Antennas (WSA 2009), Berlin, Germany, 2009.
- [i.7] ETSI TS 136 211 (V14.6.0) (04-2018): "LTE; Evolved Universal Terrestrial Radio Access (E-UTRA); Physical channels and modulation (3GPP TS 36.211 version 14.6.0 Release 14)".

- [i.8] Recommendation ITU-R M.1225 (1997): "Guidelines for evaluation of radio transmission technologies for IMT-2000".
- [i.9] European Integrated Railway Radio Enhanced Network System Requirements Specification, UIC CODE 951, GSM-R Operators Group, December 2015.
- [i.10] ETSI TR 145 050 (V15.0.0) (07-2018): "Digital cellular telecommunications system (Phase 2+) (GSM); GSM/EDGE Background for Radio Frequency (RF) requirements (3GPP TR 45.050 version 15.0.0 Release 15)".
- [i.11] Kapsch CarrierCom: "Power limitations in the extension part of the ER-GSM band", Contribution to CEPT FM56(17)047, December 2017.
- NOTE: Available at https://cept.org/Documents/fm-56/39947/fm56-17-047_power-limitations-in-the-extension-part-of-the-er-gsm-band.
- [i.12] Loic Brunel, Hervé Bonneville, Akl Charaf and Émilie Masson: "System-Level Evaluation of Next-Generation Radio Communication System for Train Operation Services", Proceedings of 7th Transport Research Arena TRA 2018, April 16-19, 2018.
- [i.13] ECC PT1(19)131: "FRMCS deployment parameters to be used in SE7 studies".

3 Definition of terms, symbols and abbreviations

3.1 Terms

Void.

3.2 Symbols

For the purposes of the present document, the following symbols apply:

λ wavelength

3.3 Abbreviations

For the purposes of the present document, the following abbreviations apply:

| | |
|--------|--|
| ACS | Adjacent Channel Selectivity |
| AMC | Adaptive Modulation and Coding |
| AWGN | Additive White Gaussian Noise |
| BS | Base Station |
| BTS | Base Transceiver Station |
| BW | BandWidth |
| CDF | Cumulative Distribution Function |
| CDL | Clustered Delay Line |
| CoMP | Coordinated Multi Point |
| COST | Cooperation of Scientific and Technical |
| CP | Cyclic Prefix |
| DL | Down Link |
| ECC | European electronic Communications Committee |
| EIRENE | European Integrated Railway radio Enhanced Network |
| EIRP | Effective Isotropic Radiated Power |
| eNB | evolved Node B |
| ETU | Extended Typical Urban model |
| E-UTRA | Evolved UMTS Terrestrial Radio Access |
| FDD | Frequency Division Duplex |
| FEC | Forward Error Correction |
| FRMCS | Future Rail Mobile Communications System |

| | |
|-------|--|
| FSTD | Frequency Switched Transmit Diversity |
| GSM | Global System for Mobile communications |
| GSM-R | Global System for Mobile communication for Railway application |
| HARQ | Hybrid Automatic Repeat-Request |
| HO | Hand Over |
| HST | High Speed Train |
| ICIC | Inter-Cell Interference Coordination |
| IMT | International Mobile Telecommunications |
| IP | Internet Protocol |
| ISD | Inter Site Distance |
| ISI | Inter-Symbol Interference |
| ITU-R | International Telecommunication Union - Radio communication sector |
| LOS | Line Of Sight |
| LTE | Long Term Evolution |
| MAC | Media Access Control |
| MCS | Modulation and Coding Scheme |
| MIMO | Multiple Input, Multiple Output |
| MISO | Multiple Input, Single Output |
| MOS | Mean Opinion Score |
| MRS | Mobile Relay Station |
| NLOS | Non Line Of Sight |
| NR | New Radio |
| OFDM | Orthogonal Frequency Division Multiplexing |
| PBCH | Physical Broadcast Channel |
| PDCCH | Physical Downlink Control Channel |
| PDCP | Packet Data Convergence Protocol |
| PDP | Power Delay Profile |
| PER | Packet Error Rate |
| PHY | PHYSical layer |
| PUCCH | Physical Uplink Control Channel |
| QAM | Quadrature Amplitude Modulation |
| QCI | QoS Class Identifier |
| RB | Resource Block |
| REC | Railways Emergency Call |
| RF | Radio Frequency |
| RLC | Radio Link Control |
| RT | Rail Telecommunications |
| SFBC | Space-Frequency Block Coding |
| SGW | Serving Gateway |
| SIMO | Single Input, Multiple Output |
| SINR | Signal to Interference-plus-Noise Ratio |
| SISO | Single Input, Single Output |
| SNR | Signal to Noise Ratio |
| SRS | System Requirement Specification |
| SSF | Special Sub-Frame |
| TCP | Transmission Control Protocol |
| TDD | Time Duplex Division |
| TRX | Transmitter/Receiver |
| UDP | User Datagram Protocol |
| UE | User Equipment |
| UIC | Union Internationale des Chemins de fer |
| UL | Up Link |
| UMTS | Universal Mobile Telecommunications System |
| USB | Universal Serial Bus |

4 Assumptions and parameters for simulations and evaluations

4.1 Introduction

In the scope of the present document, the following points are addressed:

- Simulations take into account railway specifics.
- Simulations are flexible in order to simulate different system configurations, parameter settings and scenarios.
- Consideration of different carrier band-widths (at least 1,4 MHz, 3 MHz and 5 MHz for 900 MHz band, 10 MHz for 1 900 MHz band).
- Consideration of TDD (for 1 900 MHz band) and FDD (for 900 MHz band) duplex modes.
- Consideration of different subscriber and train densities and distributions.
- Consideration of FRMCS system parameters (e.g. Cyclic Prefix).
- Different power classes of FRMCS equipment.
- Different antenna radiation patterns and tilts.
- SISO, SIMO, MISO und MIMO.
- Different installation heights of antennas.
- Different distances and densities of fixed transmitter equipment (eNB).
- Different specified and appropriate coding and modulation schemes.
- Different 3GPP Releases (e.g. LTE: ≥ 13) to take into account new features, e.g. performance improvements for high speed.

4.2 Simulation tools

Software simulations are made at radio level, i.e. above the physical layer as depicted in Figure 1. Overhead like pilots and cyclic prefixes are taken in to account, but not the overhead that are added by layers above PHY, in particular PDCP and IP headers.

Other simulations, e.g. hardware simulations and laboratory tests, could have a reference point at application level.

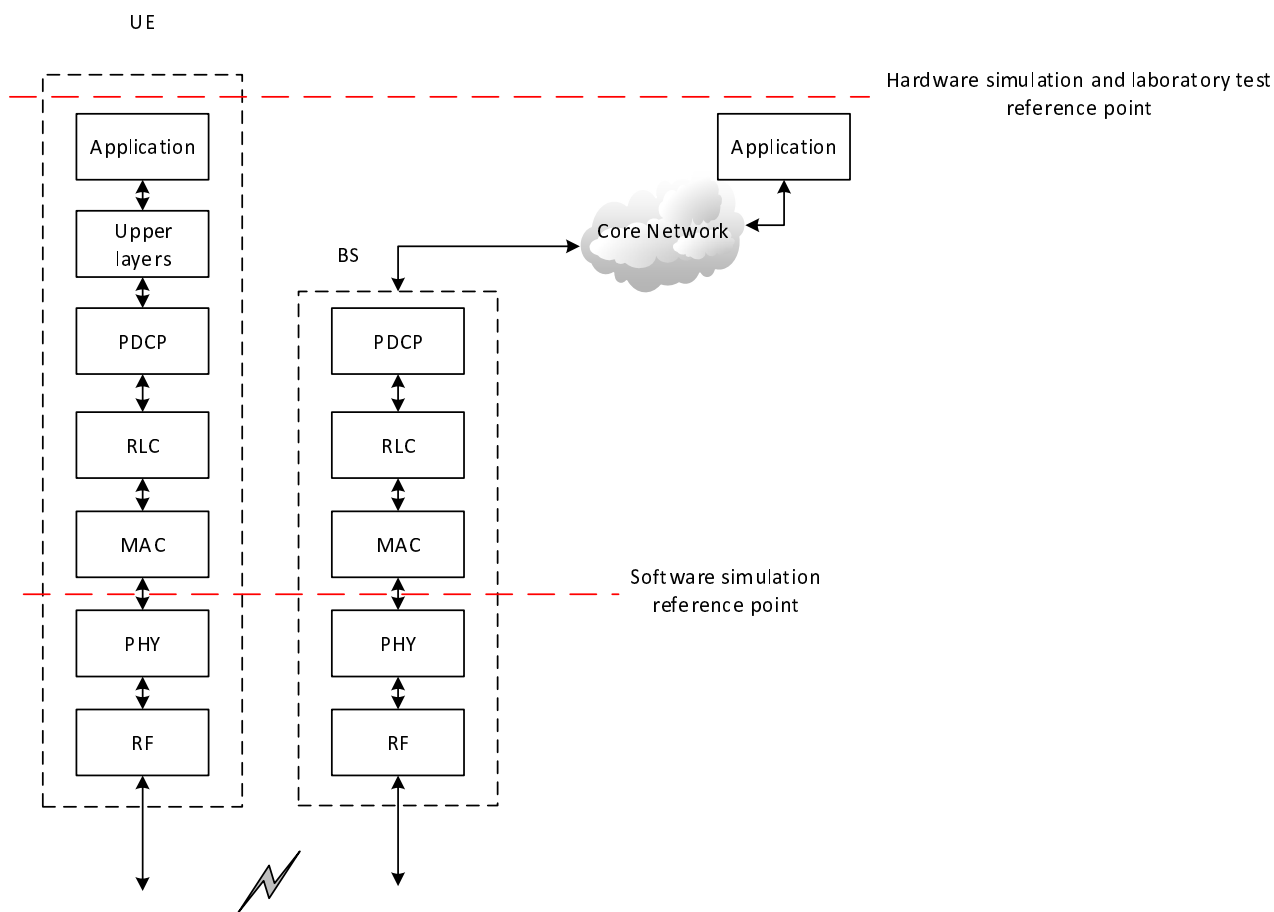

Figure 1: Reference point for the software simulations

4.3 Scenarios

The objective is to define the minimum number of scenarios which cover the majority of the radio environment.

Three scenarios have been retained: Urban, Rural, and Hilly. Urban is relative to areas where train density is high, but move at moderate speed. Rural scenario typically intends to model high speed lines. Hilly scenario intends to handle more complex situations from radio propagation point of view, with in particular extensive multi-path propagation.

Tunnels are complex scenarios, since they depend widely on tunnel shape and tunnel/train relative geometry. They are not considered in the present document as they would require a more long and thorough work.

Only train-ground communications are considered in the present document. Handset or shunting area scenarios are for further study.

Whether it is possible to have several antennas on trains roof tops and what could be their characteristic needs further discussions.

4.4 Bandwidth and transmit power

4.4.1 Bandwidths

4.4.1.1 900 MHz band

The band is operated in FDD. Three scenarios are considered on bandwidths of 1,4 MHz, 3 MHz and 5 MHz in the UIC and E-UIC bands, as depicted in Figure 2:

- 1) Scenario 1 considers GSM-R in UIC band as per today, with the addition of a 1,4 MHz LTE carrier in the upper part of E-UIC band. This scenario corresponds to a migration phase, with co-existence of both GSM-R and LTE systems.
- 2) Scenario 2 is an extension of scenario 1 with an LTE carrier extended to 3 MHz in the E-UIC band.
- 3) Scenario 3 assumes a deployment with no GSM-R and one LTE 5 MHz carrier in UIC band, overlapping the E-UIC band.

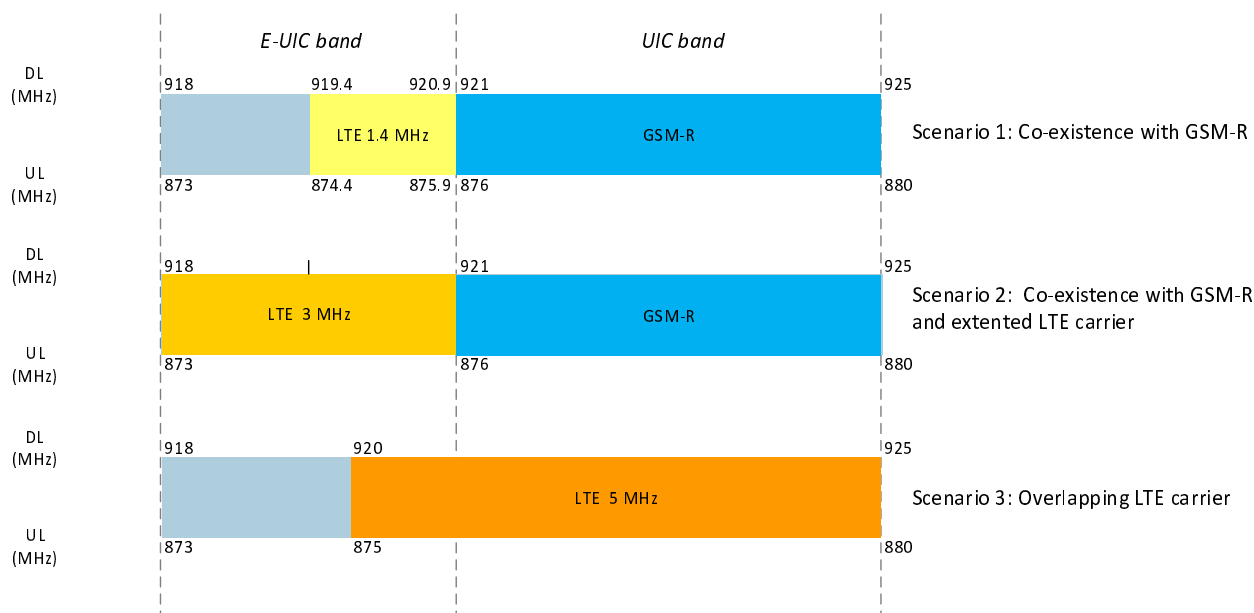

Figure 2: Carriers and bandwidths in the deployment scenarios considered

4.4.1.2 1 900 MHz band

The band is operated in TDD, with 10 MHz channel bandwidth within 1 900 MHz - 1 910 MHz frequency range.

In LTE Release 8, seven TDD configurations are specified (Table 1). Two of them are selected for the study:

- Configuration 1: providing 4 uplink subframes, 4 downlink subframes and two special subframes. This configuration is designated as 50 %/50 % (UL, DL).
- Configuration 0: providing 6 uplink subframes, 2 downlink subframes and two special subframes. This configuration is designated as 75 %/25 % (UL, DL).

The above percentage are just an indication while actual percentages of UL, DL depend on the special subframe configuration and the associated overhead (see clause 6.2.2).

Table 1: UL/DL frame configuration in LTE Rel.8 [i.7]

| Configurati on | 3GPP relea se | Downlink to uplink switch point periodicity (ms) | Subframe number | | | | | | | | | | Number of subframes / frame | | | |
|-------------------|---------------------|--|-----------------|---|---|---|---|---|---|---|---|---|-----------------------------|--------|---------|---|
| | | | 0 | 1 | 2 | 3 | 4 | 5 | 6 | 7 | 8 | 9 | DL | U L | SS F | |
| 0 | 8 | 5 | D | S | U | U | U | | D | S | U | U | U | 2 | 6 | 2 |
| 1 | 8 | 5 | D | S | U | U | D | | D | S | U | U | D | 4 | 4 | 2 |
| 2 | 8 | 5 | D | S | U | D | D | | D | S | U | D | D | 6 | 2 | 2 |
| 3 | 8 | 10 | D | S | U | U | U | | D | D | D | D | D | 6 | 3 | 1 |
| 4 | 8 | 10 | D | S | U | U | D | | D | D | D | D | D | 7 | 2 | 1 |
| 5 | 8 | 10 | D | S | U | D | D | | D | D | D | D | D | 8 | 1 | 1 |
| 6 | 8 | 5 | D | S | U | U | U | | D | S | U | U | D | 3 | 5 | 2 |

Dynamic TDD extensions introduced in later LTE releases are not considered.

However, the commercial availability of LTE chipsets with support of configuration 0 could be limited, due for example of lack of conformance testing.

4.4.2 Transmit powers

4.4.2.1 900 MHz band

Transmit power in the E-UIC band is subject to limitations in case of FRMCS system deployment uncoordinated with commercial systems operating in neighbouring bands.

The method to compute the maximum transmit power derives the impact from the adjacent channel selectivity related specifications (wideband blocking and narrow band blocking), takes into account applicable effects (0,8 dB desensitization, slope of the filtering, etc.) as well as corrections resulting from spurious emissions from base station transmission and from UE. Power limitations and ACS (Adjacent Channel Selectivity) have been found as not relevant for the present document.

Summary of the acceptable maximum transmit power of a FRMCS system in case of uncoordinated deployment is shown in Table 2.

Table 2: FRMCS acceptable transmitted power at eNB connector taking into account impact of BS Tx spurious emissions and Noise Rise from UE

| FRMCS 1,4 MHz channel centre frequency (MHz) | 918,7 | | | 920,3 | | |
|--|-------|------|----------------|-------|------|----------------|
| Standard under consideration in adjacent bands | UMTS | LTE | Multi-Standard | UMTS | LTE | Multi-Standard |
| FRMCS acceptable Tx power (dBm) | 24,2 | 22,2 | 22,2 | 48,8 | 45,8 | 48,8 |

In coordinated scenario, the maximum transmit power at 918,7 MHz can be the same than at 920,3 MHz.

More detailed information can be found in [i.11].

4.4.2.2 1 900 MHz band

Conversely to 900 MHz band, where the transmit power limitation is defined at the base station antenna connector, transmit power limitation in the 1 900 MHz band is defined through base station EIRP.

BTS EIRP 1 900 MHz: 40 dBm and 63 dBm (incl. feeder losses and antenna gain).

4.5 Antenna diagrams

4.5.1 Antenna diagrams at the base station

4.5.1.1 For 900 MHz band

Different types of antennas are deployed depending on the area. For the study, two different antennas are selected: One with a horizontal beam angle of 65° , devoted to Non Line Of Sight (NLOS) situations - typically hilly terrains and urban areas, and one more directive, with a horizontal beam angle of 30° , more suited to Line Of Sight (LOS) situations - typically rural areas.

Antenna characteristics are summarized in Table 3 and an extended description is provided in annex D.

Table 3: Summary of base station antenna patterns

| Horizontal Pattern | Vertical Pattern | Gain | Polarization | Usage |
|--------------------|------------------|---------|----------------|----------|
| 65° | 7° | 18 dB | $\pm 45^\circ$ | NLOS |
| 30° | $8,5^\circ$ | 20,5 dB | $\pm 45^\circ$ | LOS/NLOS |

4.5.1.2 For 1 900 MHz band

Table 4

| Horizontal Pattern | Vertical Pattern | Gain | Polarization | Usage |
|--------------------|------------------|---------|----------------|----------|
| 65° | 11° | 15,8 dB | $\pm 45^\circ$ | LOS/NLOS |

In document ECC PT1(19)131 "FRMCS deployment parameters to be used in SE7 studies" [i.13], common assumptions for FRMCS have been provided such as BS antenna gain (18 dB peak gain) as well as half-power beam width in azimuth (65°) and elevation ($8,5^\circ$) planes. Compared to 1 900 MHz antenna parameters used in this study, peak gain is not the same (15,8 dBi vs 18 dBi). However, this has no impact on cell edge link budget since EIRP output power includes by definition the peak antenna gain. The slight difference of the elevation half-power beam width (11° vs $8,5^\circ$) has a minor impact on the spatial distribution of signal power and can be neglected.

4.5.2 Antenna diagrams at the UE

The on-board antenna is considered as being omnidirectional with vertical polarization in case of one mounted antenna, and with vertical polarization and a separation $> 10 \lambda$ in case of two mounted antennas.

It is assumed that the UE antenna gain at low angles of elevation compensates the feeder loss.

4.6 Radio propagation aspects

4.6.1 Radio propagation model

It is beneficial that simulations be based on railway specific time-variant channel impulse responses of the radio channel in order to take into account multi-path radio propagation and Doppler-effects.

Four families of standards have been considered:

- 1) Okumura-Hata, Cost 207-GSM, COST 231 models and GSM specified models (see ETSI TR 145 050 [i.10]).
- 2) ITU-R 1997 for IMT 2000 (see Recommendation ITU-R M.1225 [i.8]) and LTE specified scenarios (see ETSI TS 136 104 [i.2] and ETSI TS 136 101 [i.3]).
- 3) ITU-R for IMT advanced (see Recommendation ITU-R M.2135-1 [i.4]).
- 4) Winner II (see [i.5]).

Recent propagation models and multipath profiles have been aimed at being used for wireless systems with a small or medium range. This is coherent since 3G and 4G standards have been developed for capacity rather than for coverage. Early defined models such as COST 207 or 231 were derived at a time when coverage was the main priority rather than high speed operation which is of particular significance within the scope of the present document.

Most relevant parameters in rail environment are then:

- Frequency range.
- Delays in Cluster Delay Line models.
- Geometry, most of models are considering 1,5 m for handheld User Equipment.
- Inter Site Distances (ISD).
- LOS scenarios are using Ricean factor with high domination of the direct path.

Characteristics of models are summarized in the following Table 5, discrepancies are in bold.

Table 5: Summary of model characteristics

| | | Railway current | Okumura-Hata, COST 207-GSM COST 231 | ITU-R IMT 2000 | ITU-R IMT advanced | Winner II |
|---|-----------------------------|----------------------------------|---|--|--|--|
| Propagation aspects | Frequency range | Band 8 (900 MHz) | 150 to 1 500 MHz | 2 000 MHz | Rural: 450 MHz to 6 GHz | Rural: 2 GHz to 6 GHz |
| | Inter Site Distance | Up to 12 km | Range up to 100 km | Max = 1 732 m | 20 km for Rural (RMa) (see note 1) | MRS 1 to 2 km 20 km for Rural (see note 1) |
| | Path clearance | LOS, Ricean < 3 dB | Ricean Factor = 0 dB air | ETU has no direct path, HST has only direct path | LOS, Ricean factor = 6 dB | LOS, Ricean factor = 6 dB |
| | Delayed paths | Up to 20 μ s | HTx: up to 20 μ s | Max delay = 5 μs | Max delay = 0,22 μs (not in line with 20 km ISD) | Max delay < 0,5 μs (not in line with 20 km ISD) |
| | Train speed | 360 km/h, projection to 500 km/h | Max = 250 km/h in R 1, no double Doppler | Max = 350 km/h with double Doppler | Max = 350 km/h | Max = 350 km/h |
| Geometry | Base Station Antenna Height | 10 to 45 m | 30 to 200 m | $\Delta hb = 0$ to 50 m, i.e. up to 46 m for 4 m train antenna height (see note 2) | Up to 35 m | 20 to 70 m |
| | Train Antenna Height | 4 m to 4,5 m | 1 to 10 m | | 1,5 m | 1,5 m/2,5 m |
| NOTE 1: Delays are shorter than what can be expected with such ISD. | | | | | | |
| NOTE 2: Δhb is the height difference between base station and train antennas. | | | | | | |

Table 6: Main characteristics of Railway context

| | | |
|---|-----------------------------|-------------------------------|
| Indeed, propagation and geometry parameters that are deemed particularly relevant for Railways are summarized below in Table 6. | Frequency range | Band 8 (900 MHz) |
| | Inter Site Distance | Up to 12 km |
| | Path clearance | LOS, Ricean < 3 dB |
| | Delayed paths | Up to 20 μ s |
| | Train speed | 360 km/h, projection 500 km/h |
| Propagation aspects | Base Station Antenna Height | 10 m to 45 m |
| | Train Antenna Height | 4 m to 4,5 m |

The Ricean factor taken here corresponds to worst case scenario. In actual deployments, higher values could be encountered, leading to more favourable channel conditions.

4.6.2 Conclusion

Okumura-Hata models and COST 207-GSM COST 231 family (see ETSI TR 145 050 [i.10]) are taken as the basis.

4.7 Frequency reuse scheme

In LTE radio, the frequency band is split in Resource Blocks (RBs) which can be allocated individually to UEs by the base station scheduler for each frame. All LTE cells may operate on the same frequency band; however, to mitigate interference from neighbouring LTE cells, one technique is to coordinate RB allocations among cells. One possible coordination scheme is fractional frequency reuse, which consists for example in allocating different RBs among two neighbouring cells to cell edge UEs, while still allocating all the RBs (at a reduced power) for cell centre UEs (see Figure 3). This can be seen as a frequency reuse factor 1 for cell centre UEs, and a frequency reuse factor > 1 (equal to 2 in Figure 3 example) for cell edge UEs. Hence, not all RBs are allocated to cell edge UEs, but this is compensated by a better SINR for those blocks.

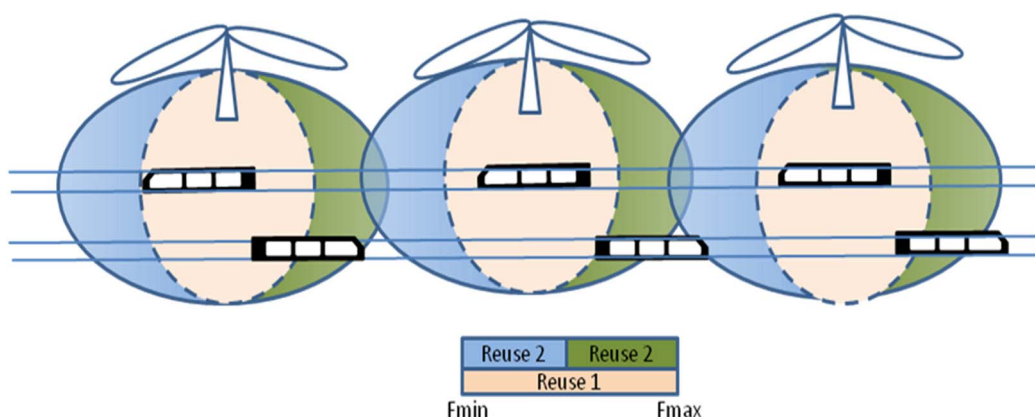

Figure 3: Example of fractional frequency reuse for rail deployment

Results should indicate which kind of Fractional Frequency Reuse techniques is used.

4.8 Summary

Table 7 sums up all the parameters.

Table 7: Summary of evaluation parameters

| Environment/scenario | Rural/Urban |
|--|--|
| Railway shape and LOS/NLOS propagation | Rural: Straight: LOS Curves: NLOS (2 separate sets of results) Hilly: NLOS only Urban: NLOS only |
| Carrier Frequency (DL/UL) (MHz) | 875,2/920,2 (for 1,4 MHz bandwidth) 874,5/919,5 (for 3 MHz bandwidth) 877,5/922,5 (for 5 MHz bandwidth) 1 905 (TDD) |
| Bandwidth (MHz) | 900 MHz 1,4 (mandatory) 3 (optional) 5 (optional) 1 900 MHz 10 MHz |

| Environment/scenario | Rural/Urban |
|--|---|
| Inter-site distance (ISD) (km) | Rural: (900 MHz) 8 Rural (1 900 MHz): 8, 6 and 4 Urban (900 MHz and 1 900 MHz): 2 and 4 |
| BS antenna height (m) | 900 MHz 18 (urban) - 30 or 40 (rural) 1 900 MHz 20 (urban) - 35 (rural) |
| Train antenna height (m) | 4,5 or 4 |
| Tower to track distance (m) | 15 |
| Neighbour cells load | Rural: 4 trains (2 in each direction) High speed: 2 trains (1 in each direction) Urban: <ul style="list-style-type: none"> • 6 trains (3 in each direction) • 4 trains (2 in each direction) See note 1 |
| Train speeds (km/h) | Urban: 80 Rural: 350 Hilly: 160 |
| DL max power (dBm) | In UIC-band: 46 before feeder (output of the BTS) 3 dB feeder loss In E-UIC band (see clause 4.4.2) 46 (output of the BTS) 3 dB feeder loss In 1 900 MHz band 40 EIRP 63 EIRP |
| UL max Power (dBm) | 23 26 31 See note 2 |
| UL Power Control | For instance: Open loop full compensation to be mentioned along with the results |
| Channel Estimation | For instance: Real channel estimation Time interpolation - to be mentioned along with the results |
| Link Channel Model Tap delay lines Clustered delay lines | Based on ETSI TS 145 005 [i.1] Urban area 6 taps Rural area 6 taps Hilly terrain 12 taps Channels for different antennas are not correlated. ETSI TS 145 005 [i.1] channel models are Tapped Delay Line models. Other Models (Recommendation ITU-R M.2135-1 [i.4]) provide additional small scale parameters (Angles of arrival/departure (AoA/AoD) of the rays). To take into account some small scales parameters, ETSI TS 145 005 [i.1] channel models can be combined with the AoA/AoD provided in ITU-R models. Since the number of taps in ETSI TS 145 005 [i.1] models (6 taps/12 taps) is generally different from ITU-R models, AoA/AoD from ITU-R models corresponding to the strongest first 6/12 taps are considered for this hybrid channel model |
| Path Loss Model (propagation model) | Urban: Okumura-Hata (LOS/NLOS effect is only taken into account in link channel model through Rice coefficient distribution for the first tap) Rural: Hata sub-urban (LOS/NLOS effect is only taken into account in link channel model through Rice coefficient distribution for the first tap) Hilly: Hata sub-urban See details in annex E |
| Shadowing standard deviation (dB) | Urban: Okumura-Hata 8 dB (NLOS only) Rural: Hata sub-urban 6 dB in LOS, 8 dB in NLOS Hilly: 8 dB (NLOS only) See details in annex E |
| Noise (dBm) | -121,4 See note 3 |

| Environment/scenario | Rural/Urban |
|---|--|
| Cyclic prefix | Rural: Extended prefix Urban: Normal prefix Hilly: Extended prefix |
| Fractional frequency reuse technique | To be mentioned along with the results |
| Antenna pattern eNB/Antenna gain | See clause 4.5.1 See note 4 |
| eNB antenna downtilt (°) | To be mentioned along with the results |
| Antenna pattern UE/antenna gain | One antenna: Omnidirectional/0 dBi - Vertical polarization Two antennas: Vertical polarization, > 10 λ separation See note 5 |
| Transmission modes | To be mentioned along with the results |
| NOTE 1: The aggregate data traffic per cell is 100 %. | |
| NOTE 2: It is considered that the UE antenna gain compensates the feeder loss. | |
| NOTE 3: Corresponds to thermal noise in a Resource Block of 180 kHz. | |
| NOTE 4: In rural environment with straight line railway shape, the 30° Horizontal Polarised antenna is assumed. | |
| NOTE 5: See clause 4.5.2. | |

4.9 Outcomes of the simulations

Output metrics need to include at least throughputs for DL and UL under the following conditions:

- Peak Data Rate.
- Average.
- 5 %-tile cell edge. This metric corresponds to the worst case of radio propagation conditions at the worst position in the cell (maximum throughput experienced by the 5 % of trains with worst throughput).

NOTE: This 5 %-tile cell edge (or Worst Cell Edge) differs from coverage specification as defined in EIRENE SRS ([i.9]), in which the specified GSM-R radio coverage probability is 95 % in each location intervals of 100 m.

Worst cell edge is 5 %-tile on every location starting from the hand over point, and therefore the associated data throughput corresponds to a much more severe criteria than the one used in EIRENE specification [i.9].

5 Simulation results

5.1 Results set 1

5.1.1 Description

The simulator used for this result set is a software chain tool using a Monte-Carlo statistical approach. It simulates a complete LTE PHY layer, i.e. it operates at '*Software simulation reference point*' as defined in Figure 1.

The simulator considers multiple cells in a linear deployment along the track and encompasses link-level simulation as well as system-level simulation.

Link level simulations allow to compute the bit error rate and Packet/block Error Rate (PER) of the radio transmission scheme, including detailed simulation of modulation and coding, MIMO scheme, channel estimation, small-scale fading effects and AWGN. However, link level simulation does not include any effect of large-scale fading, i.e. distance-dependent path-loss and shadowing, which impacts the (experienced) Signal to Noise Ratio (SNR) as well as the inter-cell interference level.

System level simulations allows to quantify the impact of inter-cell interference on the system throughput at cell level.

The simulation tool comprises then (see also [i.12]):

Step 1: Link level simulation

- 1) Computation of the PER_i vs. Signal to Interference-plus-Noise Ratio (SINR) for N different transmission schemes (characterized by a specific modulation, coding rate, and MIMO scheme) that results in link level throughputs T_i , $i=1, \dots, N$ (assuming AWGN interference).
- 2) For each transmission scheme i and each SINR value, computation of the resulting throughput $T_{res,i}(SINR)$ taking into account PER as:

$$T_{res,i} = T_i \times (1 - PER_i(SINR))$$

- 3) For each SINR, storage in a look-up table of the maximum resulting throughput as shown in Figure 4 among all transmission schemes (modulation, coding rate, MIMO) as a result of ideal link adaptation to large-scale channel properties:

$$T_{\max}(SINR) = \arg \max_i (T_{res,i}(SINR))$$

Step 2: System level simulation

- 1) For many drops of User Equipments (UEs) and many large-scale channel realizations (including large-scale fading statistics), computation of the resulting SINR for each UE:
 - A drop is a realization of UE positions within the cells. These positions are randomly drawn under the constraints of the scenario of interest. For instance, the UE distribution depends on UE density.
- 2) From all the drops, computation of the Cumulative Distribution Function (CDF) of the throughput by using the obtained SINR values as inputs in the look-up table $T_{\max}(SINR)$ obtained in the link-level evaluation step.

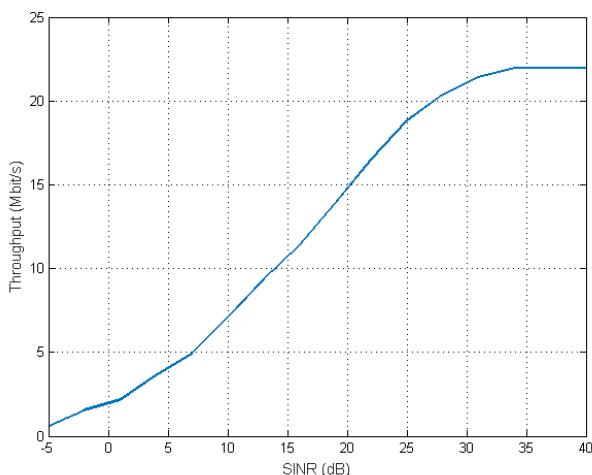

Figure 4: Maximum resulting throughput example for a given transmission scheme and UE speed (link level simulation)

Antenna patterns are taken into account together with antenna down-tilt in the system level step. Large-scale fading statistics follows a log-normal distribution.

In this railway environment, a straight railway line is assumed, with trains moving on both directions (see Figure 5). The Inter Site Distance (ISD) is set depending on the scenario, i.e. ISD is set to 8 km for rural and to 2 km for urban, as proposed in clause 4.8.

Each train embeds one UE and train positions are drawn following a uniform random distribution ensuring the train density requirement for each scenario, i.e. 1 train per cell in each direction in high velocity train scenario, 2 in rural scenario and 3 in urban scenario. These train positions form a train position set, each set corresponding to a UE drop.

A worst-case interference level is assumed: all active cells are fully loaded in both UL and DL, i.e. transmission occurs over the whole bandwidth. DL interference experienced by the train in the serving cell depends on its position. UL interference in the serving cell depends on the position of the trains in neighbour cells.

In total, 1 600 train positions sets have been considered during simulations, with 400 channel models realizations per set.

From system-level simulations, the cell average spectral efficiency and the cell-edge throughput (e.g. the 5 %-tile throughput) are computed. For getting the 5 %-tile throughput, the throughput CDF at any position of a track is computed. This is different from the cell-edge throughput computed in 3GPP, which is the cell 5 %-tile throughput taken over the entire cell coverage. The resulting curve allows evaluating the 5 %-tile data throughput at the worst position of the train on the track.

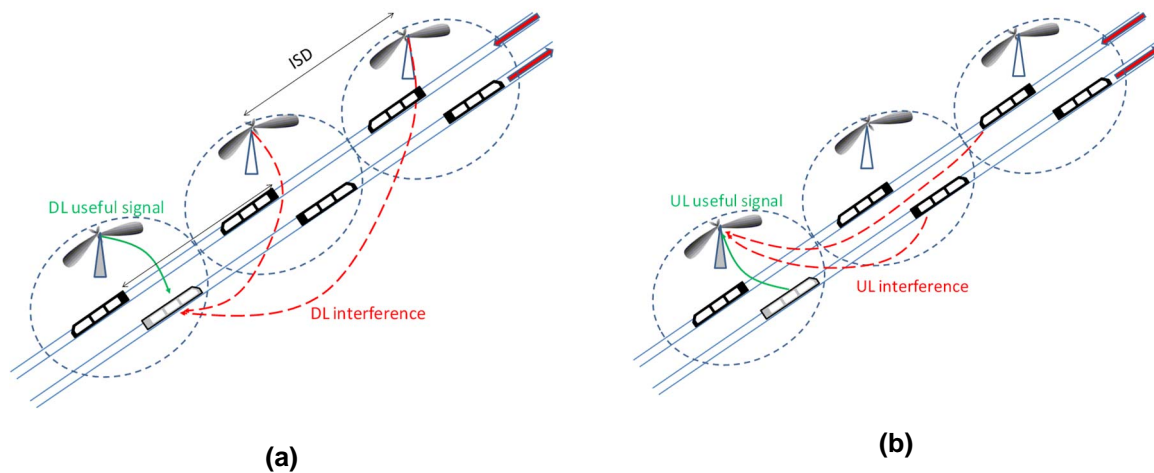

Figure 5: Railway line configuration and inter-cell interference (a: downlink; b: uplink)

5.1.2 Specific assumptions and parameters

5.1.2.0 Frequency reuse scheme

The simulations do not consider any fractional frequency reuse algorithm. Separate results are provided for different frequency reuse factors (hard frequency reuse), leading to a strong decrease of offered throughput in cell centres for frequency reuse > 1 .

However, with a fractional frequency reuse algorithm, the throughput results with frequency reuse 2 or 3 will be the ones cell edge UEs could experience, while frequency reuse 1 results should be considered for cell centre UEs.

5.1.2.1 FDD 900 MHz band

A **first round** of simulations has been made with the following assumptions:

- The noise figures at eNB and UE have not been considered.
- Link channel model: As foreseen in clause 4.7, link level simulations combine Power Delay Profiles (PDPs) taken from ETSI TS 145 005 [i.1] and geometrical aspects (angle of arrival and angle of departure of the rays) of Clustered Delay Lines (CDLs) from Recommendation ITU-R M.2135-1 [i.4].
- Channel estimation includes a time-interpolation between consecutive subframes. It introduces a small processing delay (0,07 ms in downlink with 2 transmit antennas, 0,14 ms with 4 transmit antennas and 0,29 ms in uplink) but lowers Doppler effect.

- In DL, the MIMO schemes that have been chosen for the simulations are transmission schemes providing transmit diversity (see clause 6.3.4.3 of ETSI TS 136 211 [i.7]), as they are more robust to the high train velocity:
 - The transmit diversity scheme with two transmit antennas is the Alamouti Space Frequency Block Code (SFBC) applied on two adjacent sub-carriers (spatial diversity of $2 N_R$ with N_R number of receive antennas).
 - The transmit diversity scheme with four transmit antennas is a combination of Alamouti SFBC and Frequency Switched Transmit Diversity (FSTD) on four adjacent sub-carriers (spatial diversity of $4 N_R$).
- In UL, single-antenna transmission only is considered (SIMO) (diversity gain of N_R).
- Transmit power in DL is 43 dBm taking into account a 3 dB feeder loss. This power is spread over all the antennas.
- Transmit power in UL is 23 dBm.
- Antenna tilt is 3 degrees downtilt, if not stated otherwise.
- Bandwidth is 1,4 MHz, centred at 875,2/920,2 MHz.
- Rice factor for rural model (high speed scenario) is 0,4475 dB. There is no line of sight component in the other models.
- Large scale shadowing standard deviation is 4 dB in Rural model, and 8 dB for Urban and Hilly models.
- It is considered that antennas at base station and on train are using vertical polarization.

A **second round** of simulations has then been made, with some differences in the assumptions. In the first round, the path loss computed to assess neighbouring cells interference for Rural and Hilly scenarios is computed with Okumura-Hata model, whatever the distance from the victim and the interference source. After analysis, this was considered too pessimistic, since the probability of LOS component for far away interference source becomes low. For the second round of simulations, a breakpoint distance of 8 km has been introduced. For source-victim distance below this breaking point, Okumura-Hata model is kept. However, for distance above the breaking point, a stronger attenuation (Hata model) is assumed for interfering signals. As a consequence, the serving cell in Rural and Hilly scenarios is subject to lower interference levels compared with previous results.

In order to better align with result set §3 assumptions, the following two parameters have been modified:

- Train antenna height: 4 m.
- BS antenna height: 40 m.

In this second round:

- Transmit powers in UL are 23 dBm, 26 dBm and 31 dBm.
- At the base station, one TRX (Transmitter/Receiver) is assumed per antenna, and the feeder loss (distribution cable) of 3 dB is assumed per antenna connector. Hence, the maximum transmit power is 43 dBm at each antenna connector. For a DL 2x2 transmission mode, the total power transmitted is 46 dBm (2 x 43 dBm), and 49 dBm for 4x2 transmission mode (4 x 43 dBm). In the first round, the transmitted power was assumed to be spread among the antennas, with one feeder loss for all the antennas, i.e. total transmit power was 43 dBm in all transmission modes.
- A noise figure at receiver of 3 dB at the base station and of 5 dB at the UE is introduced (was not considered in the first round).
- The noise power is applied only to the resource blocks actually used. Bandwidths are 1,4 MHz, 3 MHz and 5 MHz.
- Large scale shadowing standard deviation is 6 dB in Rural model, and 8 dB for Urban and Hilly models (in line with Table 7).

Other assumptions are kept unchanged.

The following points are clarifications that apply to first and second rounds of simulations:

- Only co-channel interference is taken into account. This co-channel interference is added as noise over the wanted signal. Hence, for frequency reuse 2 and 3 schemes, the interference is considered in the sub-bands only.
- The total transmit power is used independently of the frequency reuse scheme. This turns into a higher transmit power density in frequency reuse 2 and 3 compared to frequency reuse 1.
- The antenna polarization mismatch between base station and UE due to the usage of cross-polarized antennas at the base station has not been taken into account.
- The shadowing is correlated over a distance of 100 m.

5.1.2.2 TDD 1 900 MHz band

One round of simulation has been made.

For TDD mode, UL and DL are simulated separately and a scaling is made based on UL/DL configuration, and some additional overhead.

Simulation did not consider HARQ.

5.1.3 Results

5.1.3.1 Introduction

Simulations have been made for the different scenarios foreseen in clause 4 and considering frequency reuse factors of 1, 2 and 3.

The different scenarios simulated are described in Table 8.

Table 8: Scenarios summary

| Scenario name | Model and speed | ISD (km) | Neighbour cell load (trains) |
|---------------|------------------------|----------|------------------------------|
| Urban | Urban (NLOS, 80 km/h) | 2 | 6 |
| High Density | Urban (NLOS, 80 km/h) | 4 | 4 |
| Hilly | Hilly (NLOS, 160 km/h) | 8 | 2 |
| High speed | Rural (LOS, 350 km) | 8 | 2 |

A summary of the throughput performance is provided in the clauses below. In the summary tables:

- **cell centre** column corresponds to the maximum throughput available at the cell centre. It is the maximum data throughput that can be expected in a cell for the scenario considered and corresponds to the *Peak Data Rate* defined in clause 4.9;
- **median cell edge** corresponds to the 50 %-tile value at the worst position in the cell; and
- **worst cell edge** to the 5 %-tile value at the worst position in the cell (see clause 4.9).

UL and DL throughput values correspond to the total throughputs available in the cell, to be shared among the different trains that are served by the base station.

For the second round of results, metrics have been modified to average the effect of shadowing around each position, by averaging the 50 %-tile and the 5 %-tile values over a sliding window of 100 m. The reasoning is to mitigate the impact on throughput metric of deep fading events, since the train is moving and will not in reality encounter these events during a time long enough to actually impact the transmission of a packet.

Hence, for second round of results, the output metrics are the following:

- **cell centre** metric is kept unchanged;

- **smth. 100 m median cell edge** (Smoothed 100 m median cell edge) corresponds to the 50 %-tile value at the worst position in the cell computed over a position sliding window of 100 m; and
- **smth. 100 m worst cell edge** (Smoothed 100 m worst cell edge) corresponds to the 5 %-tile value at the worst position in the cell computed over a position sliding window of 100 m.

5.1.3.2 Results for 900 MHz band

5.1.3.2.1 Results at 1,4 MHz - First round

High speed scenario

Table 9: Set §1 - First Round - High speed scenario

| Speed (km/h) | DL | Reuse factor | Throughput (Mbit/s) | | | Speed (km/h) | UL | Reuse factor | Throughput (Mbit/s) | | |
|--------------|-----|--------------|---------------------|------------------|-----------------|--------------|-----|--------------|---------------------|------------------|-----------------|
| | | | Cell centre | Median cell edge | Worst cell edge | | | | Cell centre | Median cell edge | Worst cell edge |
| 350 | 2x2 | 1 | 3,50 | 0,30 | 0 | 350 | 1x2 | 1 | 3,60 | 0,25 | 0 |
| 350 | 4x2 | 1 | 3,50 | 0,40 | 0 | 350 | 1x4 | 1 | 3,60 | 0,40 | 0 |
| 350 | 2x2 | 2 | 1,75 | 1,00 | 0,45 | 350 | 1x2 | 2 | 1,80 | 0,75 | 0,30 |
| 350 | 4x2 | 2 | 1,75 | 1,20 | 0,45 | 350 | 1x4 | 2 | 1,80 | 1,0 | 0,50 |
| 350 | 2x2 | 3 | 1,20 | 1,20 | 0,50 | 350 | 1x2 | 3 | 1,20 | 0,70 | 0,40 |
| 350 | 4x2 | 3 | 1,20 | 1,10 | 0,60 | 350 | 1x4 | 3 | 1,20 | 0,80 | 0,60 |

Urban scenario

Table 10: Set §1 - First Round - Urban scenario

| Speed (km/h) | DL | Reuse factor | Throughput (Mbit/s) | | | Speed (km/h) | UL | Reuse factor | Throughput (Mbit/s) | | |
|--------------|-----|--------------|---------------------|------------------|-----------------|--------------|-----|--------------|---------------------|------------------|-----------------|
| | | | Cell centre | Median cell edge | Worst cell edge | | | | Cell centre | Median cell edge | Worst cell edge |
| 80 | 2x2 | 1 | 4,20 | 0,40 | 0 | 80 | 1x2 | 1 | 4,40 | 0 | 0 |
| 80 | 4x2 | 1 | 4,00 | 0,40 | 0 | 80 | 1x4 | 1 | 4,40 | 0 | 0 |
| 80 | 2x2 | 2 | 2,20 | 1,12 | 0,10 | 80 | 1x2 | 2 | 2,20 | 0,30 | 0 |
| 80 | 4x2 | 2 | 2,00 | 1,25 | 0,10 | 80 | 1x4 | 2 | 2,20 | 0,55 | 0 |
| 80 | 2x2 | 3 | 1,40 | 1,25 | 0,30 | 80 | 1x2 | 3 | 1,45 | 0,45 | 0 |
| 80 | 4x2 | 3 | 1,30 | 1,15 | 0,30 | 80 | 1x4 | 3 | 1,45 | 0,75 | 0,05 |

High density scenario

Table 11: Set §1 - First Round - High density scenario

| Speed (km/h) | DL | Reuse factor | Throughput (Mbit/s) | | | Speed (km/h) | UL | Reuse factor | Throughput (Mbit/s) | | |
|--------------|-----|--------------|---------------------|------------------|-----------------|--------------|-----|--------------|---------------------|------------------|-----------------|
| | | | Cell centre | Median cell edge | Worst cell edge | | | | Cell centre | Median cell edge | Worst cell edge |
| 80 | 2x2 | 1 | 4,20 | 0,30 | 0 | 80 | 1x2 | 1 | 4,30 | 0 | 0 |
| 80 | 4x2 | 1 | 4,00 | 0,40 | 0 | 80 | 1x4 | 1 | 4,30 | 0 | 0 |
| 80 | 2x2 | 2 | 2,10 | 1,25 | 0,10 | 80 | 1x2 | 2 | 2,20 | 0,30 | 0 |
| 80 | 4x2 | 2 | 2,00 | 1,25 | 0,15 | 80 | 1x4 | 2 | 2,20 | 0,50 | 0 |
| 80 | 2x2 | 3 | 1,40 | 1,25 | 0,4 | 80 | 1x2 | 3 | 1,45 | 0,45 | 0 |
| 80 | 4x2 | 3 | 1,30 | 1,12 | 0,30 | 80 | 1x4 | 3 | 1,5 | 0,75 | 0,1 |

Hilly scenario

Table 12: Set §1 - First Round - Hilly scenario

| Speed (km/h) | DL | Reuse factor | Throughput (Mbit/s) | | | Speed (km/h) | UL | Reuse factor | Throughput (Mbit/s) | | |
|--------------|-----|--------------|---------------------|------------------|-----------------|--------------|-----|--------------|---------------------|------------------|-----------------|
| | | | Cell centre | Median cell edge | Worst cell edge | | | | Cell centre | Median cell edge | Worst cell edge |
| 160 | 2x2 | 1 | 2,10 | 0,25 | 0 | 160 | 1x2 | 1 | 3,60 | 0,25 | 0 |
| 160 | 4x2 | 1 | 2,40 | 0,35 | 0 | 160 | 1x4 | 1 | 3,60 | 0,50 | 0 |
| 160 | 2x2 | 2 | 1,00 | 0,90 | 0,15 | 160 | 1x2 | 2 | 1,80 | 0,75 | 0,15 |
| 160 | 4x2 | 2 | 1,20 | 1,10 | 0,13 | 160 | 1x4 | 2 | 1,80 | 1,13 | 0,25 |
| 160 | 2x2 | 3 | 0,70 | 0,70 | 0,25 | 160 | 1x2 | 3 | 1,20 | 0,40 | 0,20 |
| 160 | 4x2 | 3 | 0,85 | 0,80 | 0,30 | 160 | 1x4 | 3 | 1,20 | 1,0 | 0,3 |

The figures in the summary tables are picked up from (throughput vs. distance to base station) curves. An example of such a curve is provided in Figure 6; the full set can be found in annex B.

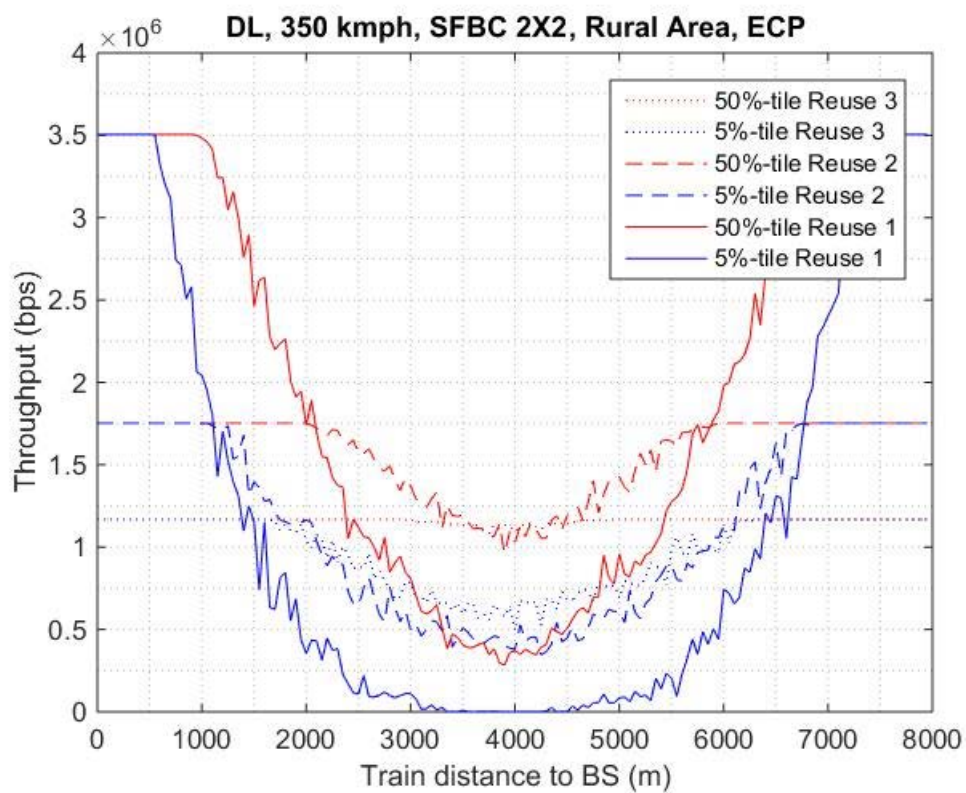

Figure 6: Example of throughput vs distance to base station (first round)

5.1.3.2.2 Results at 1,4 MHz - Second round

High speed scenario

Table 13: Set §1 - Second Round - 1,4 MHz - High density scenario

| Bandwidth (MHz) | Speed (km/h) | Reuse factor | DL | Throughput (Mbit/s) | | |
|-----------------|--------------|--------------|-----|---------------------|------------------------------|-----------------------------|
| | | | | Cell centre | Smth. 100 m median cell edge | Smth. 100 m worst cell edge |
| 1,4 | 350 | 1 | 2x2 | 4,12 | 1,24 | 0,11 |
| | | 1 | 4x2 | 3,86 | 1,25 | 0,12 |
| | | 2 | 2x2 | 2,06 | 2,05 | 1,06 |
| | | 2 | 4x2 | 1,93 | 1,87 | 1,00 |
| | | 3 | 2x2 | 1,37 | 1,37 | 1,17 |
| | | 3 | 4x2 | 1,29 | 1,29 | 1,08 |

| Bandwidth (MHz) | Speed (km/h) | Tx Power (dBm) | Reuse factor | UL | Throughput (Mbit/s) | | |
|-----------------|--------------|----------------|--------------|-----|---------------------|------------------------------|-----------------------------|
| | | | | | Cell centre | Smth. 100 m median cell edge | Smth. 100 m worst cell edge |
| 1,4 | 350 | 23 | 1 | 1x2 | 3,81 | 0,28 | 0,00 |
| | | | 1 | 1x4 | 3,85 | 0,53 | 0,00 |
| | | | 2 | 1x2 | 1,90 | 1,49 | 0,84 |
| | | | 2 | 1x4 | 1,92 | 1,85 | 1,19 |
| | | | 3 | 1x2 | 1,27 | 1,15 | 0,78 |
| | | | 3 | 1x4 | 1,28 | 1,28 | 1,06 |
| 1,4 | 350 | 26 | 1 | 1x2 | 3,81 | 0,20 | 0,00 |
| | | | 1 | 1x4 | 3,85 | 0,38 | 0,00 |
| | | | 2 | 1x2 | 1,90 | 1,48 | 0,81 |
| | | | 2 | 1x4 | 1,92 | 1,84 | 1,15 |
| | | | 3 | 1x2 | 1,27 | 1,17 | 0,81 |
| | | | 3 | 1x4 | 1,28 | 1,28 | 1,10 |
| 1,4 | 350 | 31 | 1 | 1x2 | 3,81 | 0,09 | 0,00 |
| | | | 1 | 1x4 | 3,85 | 0,20 | 0,00 |
| | | | 2 | 1x2 | 1,90 | 1,39 | 0,71 |
| | | | 2 | 1x4 | 1,92 | 1,75 | 1,07 |
| | | | 3 | 1x2 | 1,27 | 1,17 | 0,80 |
| | | | 3 | 1x4 | 1,28 | 1,28 | 1,09 |

Urban scenario

Table 14: Set §1 - Second Round - 1,4 MHz - Urban scenario

| Bandwidth (MHz) | Speed (km/h) | Reuse factor | DL | Throughput (Mbit/s) | | |
|-----------------|--------------|--------------|-----|---------------------|------------------------------|-----------------------------|
| | | | | Cell centre | Smth. 100 m median cell edge | Smth. 100 m worst cell edge |
| 1,4 | 80 | 1 | 2x2 | 3,19 | 0,42 | 0,00 |
| | | 1 | 4x2 | 3,16 | 0,46 | 0,00 |
| | | 2 | 2x2 | 1,59 | 1,28 | 0,23 |
| | | 2 | 4x2 | 1,58 | 1,26 | 0,24 |
| | | 3 | 2x2 | 1,06 | 0,98 | 0,47 |
| | | 3 | 4x2 | 1,05 | 0,93 | 0,49 |

| Bandwidth (MHz) | Speed (km/h) | Tx Power (dBm) | Reuse factor | UL | Throughput (Mbit/s) | | |
|-----------------|--------------|----------------|--------------|-----|---------------------|------------------------------|-----------------------------|
| | | | | | Cell centre | Smth. 100 m median cell edge | Smth. 100 m worst cell edge |
| 1,4 | 80 | 23 | 1 | 1x2 | 4,62 | 0,81 | 0,00 |
| | | | 1 | 1x4 | 4,65 | 1,49 | 0,01 |
| | | | 2 | 1x2 | 2,31 | 1,41 | 0,37 |
| | | | 2 | 1x4 | 2,33 | 2,12 | 0,64 |
| | | | 3 | 1x2 | 1,54 | 1,44 | 0,52 |
| | | | 3 | 1x4 | 1,55 | 1,55 | 0,86 |
| 1,4 | 80 | 26 | 1 | 1x2 | 4,62 | 0,71 | 0,00 |
| | | | 1 | 1x4 | 4,65 | 1,24 | 0,00 |
| | | | 2 | 1x2 | 2,31 | 1,30 | 0,30 |
| | | | 2 | 1x4 | 2,33 | 1,93 | 0,54 |
| | | | 3 | 1x2 | 1,54 | 1,36 | 0,47 |
| | | | 3 | 1x4 | 1,55 | 1,55 | 0,80 |
| 1,4 | 80 | 31 | 1 | 1x2 | 4,62 | 0,44 | 0,00 |
| | | | 1 | 1x4 | 4,65 | 0,83 | 0,00 |
| | | | 2 | 1x2 | 2,31 | 1,09 | 0,20 |
| | | | 2 | 1x4 | 2,33 | 1,65 | 0,39 |
| | | | 3 | 1x2 | 1,54 | 1,21 | 0,38 |
| | | | 3 | 1x4 | 1,55 | 1,55 | 0,65 |

High density scenario

Table 15: Set §1 - Second Round - 1,4 MHz - High density scenario

| Bandwidth (MHz) | Speed (km/h) | Reuse factor | DL | Throughput (Mbit/s) | | |
|-----------------|--------------|--------------|-----|---------------------|------------------------------|-----------------------------|
| | | | | Cell centre | Smth. 100 m median cell edge | Smth. 100 m worst cell edge |
| 1,4 | 80 | 1 | 2x2 | 3,19 | 0,00 | 0,00 |
| | | 1 | 4x2 | 3,16 | 0,00 | 0,00 |
| | | 2 | 2x2 | 1,59 | 0,59 | 0,00 |
| | | 2 | 4x2 | 1,58 | 0,59 | 0,00 |
| | | 3 | 2x2 | 1,06 | 0,80 | 0,11 |
| | | 3 | 4x2 | 1,05 | 0,78 | 0,12 |

| Bandwidth (MHz) | Speed (km/h) | Tx Power (dBm) | Reuse factor | UL | Throughput (Mbit/s) | | |
|-----------------|--------------|----------------|--------------|-----|---------------------|------------------------------|-----------------------------|
| | | | | | Cell centre | Smth. 100 m median cell edge | Smth. 100 m worst cell edge |
| 1,4 | 80 | 23 | 1 | 1x2 | 4,62 | 0,10 | 0,00 |
| | | | 1 | 1x4 | 4,65 | 0,26 | 0,00 |
| | | | 2 | 1x2 | 2,31 | 0,53 | 0,03 |
| | | | 2 | 1x4 | 2,33 | 0,88 | 0,07 |
| | | | 3 | 1x2 | 1,54 | 0,56 | 0,11 |
| | | | 3 | 1x4 | 1,55 | 0,91 | 0,23 |
| 1,4 | 80 | 26 | 1 | 1x2 | 4,62 | 0,07 | 0,00 |
| | | | 1 | 1x4 | 4,65 | 0,17 | 0,00 |
| | | | 2 | 1x2 | 2,31 | 0,48 | 0,01 |
| | | | 2 | 1x4 | 2,33 | 0,81 | 0,05 |
| | | | 3 | 1x2 | 1,54 | 0,55 | 0,10 |
| | | | 3 | 1x4 | 1,55 | 0,90 | 0,21 |
| 1,4 | 80 | 31 | 1 | 1x2 | 4,62 | 0,01 | 0,00 |
| | | | 1 | 1x4 | 4,65 | 0,07 | 0,00 |
| | | | 2 | 1x2 | 2,31 | 0,38 | 0,00 |
| | | | 2 | 1x4 | 2,33 | 0,67 | 0,02 |
| | | | 3 | 1x2 | 1,54 | 0,52 | 0,07 |
| | | | 3 | 1x4 | 1,55 | 0,85 | 0,16 |

Hilly scenario

Table 16: Set §1 - Second Round - 1,4 MHz - Hilly scenario

| Bandwidth (MHz) | Speed (km/h) | Reuse factor | DL | Throughput (Mbit/s) | | |
|-----------------|--------------|--------------|-----|---------------------|------------------------------|-----------------------------|
| | | | | Cell centre | Smth. 100 m median cell edge | Smth. 100 m worst cell edge |
| 1,4 | 160 | 1 | 2x2 | 2,36 | 0,00 | 0,00 |
| | | 1 | 4x2 | 2,23 | 0,00 | 0,00 |
| | | 2 | 2x2 | 1,18 | 0,71 | 0,04 |
| | | 2 | 4x2 | 1,12 | 0,70 | 0,03 |
| | | 3 | 2x2 | 0,79 | 0,70 | 0,19 |
| | | 3 | 4x2 | 0,74 | 0,69 | 0,19 |

| Bandwidth (MHz) | Speed (km/h) | Tx Power (dBm) | Reuse factor | UL | Throughput (Mbit/s) | | |
|-----------------|--------------|----------------|--------------|-----|---------------------|------------------------------|-----------------------------|
| | | | | | Cell centre | Smth. 100 m median cell edge | Smth. 100 m worst cell edge |
| 1,4 | 160 | 23 | 1 | 1x2 | 3,87 | 0,00 | 0,00 |
| | | | 1 | 1x4 | 3,87 | 0,00 | 0,00 |
| | | | 2 | 1x2 | 1,93 | 0,42 | 0,02 |
| | | | 2 | 1x4 | 1,93 | 0,69 | 0,06 |
| | | | 3 | 1x2 | 1,29 | 0,44 | 0,08 |
| | | | 3 | 1x4 | 1,29 | 0,72 | 0,18 |
| 1,4 | 160 | 26 | 1 | 1x2 | 3,87 | 0,00 | 0,00 |
| | | | 1 | 1x4 | 3,87 | 0,00 | 0,00 |
| | | | 2 | 1x2 | 1,93 | 0,40 | 0,02 |
| | | | 2 | 1x4 | 1,93 | 0,66 | 0,05 |
| | | | 3 | 1x2 | 1,29 | 0,44 | 0,09 |
| | | | 3 | 1x4 | 1,29 | 0,73 | 0,19 |
| 1,4 | 160 | 31 | 1 | 1x2 | 3,87 | 0,00 | 0,00 |
| | | | 1 | 1x4 | 3,87 | 0,00 | 0,00 |
| | | | 2 | 1x2 | 1,93 | 0,32 | 0,01 |
| | | | 2 | 1x4 | 1,93 | 0,56 | 0,03 |
| | | | 3 | 1x2 | 1,29 | 0,43 | 0,08 |
| | | | 3 | 1x4 | 1,29 | 0,71 | 0,16 |

5.1.3.2.3 Results at 3 MHz

High speed scenario

Table 17: Set §1 - Second Round - 3 MHz - High speed scenario

| Bandwidth (MHz) | Speed (km/h) | Reuse factor | DL | Throughput (Mbit/s) | | |
|-----------------|--------------|--------------|-----|---------------------|------------------------------|-----------------------------|
| | | | | Cell centre | Smth. 100 m median cell edge | Smth. 100 m worst cell edge |
| 3,0 | 350 | 1 | 2x2 | 10,31 | 3,10 | 0,28 |
| | | 1 | 4x2 | 9,64 | 3,11 | 0,29 |
| | | 2 | 2x2 | 5,15 | 5,12 | 2,65 |
| | | 2 | 4x2 | 4,82 | 4,68 | 2,51 |
| | | 3 | 2x2 | 3,44 | 3,44 | 2,93 |
| | | 3 | 4x2 | 3,21 | 3,21 | 2,71 |

| Bandwidth (MHz) | Speed (km/h) | Tx Power (dBm) | Reuse factor | UL | Throughput (Mbit/s) | | |
|-----------------|--------------|----------------|--------------|-----|---------------------|------------------------------|-----------------------------|
| | | | | | Cell centre | Smth. 100 m median cell edge | Smth. 100 m worst cell edge |
| 3,0 | 350 | 23 | 1 | 1x2 | 9,55 | 0,72 | 0,00 |
| | | | 1 | 1x4 | 9,61 | 1,35 | 0,00 |
| | | | 2 | 1x2 | 4,77 | 3,31 | 1,86 |
| | | | 2 | 1x4 | 4,81 | 4,23 | 2,71 |
| | | | 3 | 1x2 | 3,18 | 2,58 | 1,68 |
| | | | 3 | 1x4 | 3,20 | 3,17 | 2,28 |
| 3,0 | 350 | 26 | 1 | 1x2 | 9,55 | 0,47 | 0,00 |
| | | | 1 | 1x4 | 9,61 | 0,94 | 0,00 |
| | | | 2 | 1x2 | 4,77 | 3,37 | 1,93 |
| | | | 2 | 1x4 | 4,81 | 4,28 | 2,74 |
| | | | 3 | 1x2 | 3,18 | 2,67 | 1,82 |
| | | | 3 | 1x4 | 3,20 | 3,20 | 2,48 |
| 3,0 | 350 | 31 | 1 | 1x2 | 9,55 | 0,20 | 0,00 |
| | | | 1 | 1x4 | 9,61 | 0,48 | 0,00 |
| | | | 2 | 1x2 | 4,77 | 3,29 | 1,73 |
| | | | 2 | 1x4 | 4,81 | 4,22 | 2,64 |
| | | | 3 | 1x2 | 3,18 | 2,74 | 1,91 |
| | | | 3 | 1x4 | 3,20 | 3,20 | 2,62 |

Urban scenario

Table 18: Set §1 - Second Round - 3 MHz - Urban scenario

| Bandwidth (MHz) | Speed (km/h) | Reuse factor | DL | Throughput (Mbit/s) | | |
|-----------------|--------------|--------------|-----|---------------------|------------------------------|-----------------------------|
| | | | | Cell centre | Smth. 100 m median cell edge | Smth. 100 m worst cell edge |
| 3,0 | 80 | 1 | 2x2 | 7,96 | 1,06 | 0,00 |
| | | 1 | 4x2 | 7,89 | 1,14 | 0,00 |
| | | 2 | 2x2 | 3,98 | 3,20 | 0,57 |
| | | 2 | 4x2 | 3,95 | 3,14 | 0,60 |
| | | 3 | 2x2 | 2,65 | 2,45 | 1,17 |
| | | 3 | 4x2 | 2,63 | 2,32 | 1,23 |

| Bandwidth (MHz) | Speed (km/h) | Tx Power (dBm) | Reuse factor | UL | Throughput (Mbit/s) | | |
|-----------------|--------------|----------------|--------------|-----|---------------------|------------------------------|-----------------------------|
| | | | | | Cell centre | Smth. 100 m median cell edge | Smth. 100 m worst cell edge |
| 3,0 | 80 | 23 | 1 | 1x2 | 11,58 | 2,07 | 0,00 |
| | | | 1 | 1x4 | 11,65 | 3,79 | 0,01 |
| | | | 2 | 1x2 | 5,79 | 3,51 | 0,95 |
| | | | 2 | 1x4 | 5,83 | 5,23 | 1,61 |
| | | | 3 | 1x2 | 3,86 | 3,54 | 1,34 |
| | | | 3 | 1x4 | 3,88 | 3,88 | 2,16 |
| 3,0 | 80 | 26 | 1 | 1x2 | 11,58 | 1,85 | 0,00 |
| | | | 1 | 1x4 | 11,65 | 3,15 | 0,00 |
| | | | 2 | 1x2 | 5,79 | 3,26 | 0,74 |
| | | | 2 | 1x4 | 5,83 | 4,80 | 1,36 |
| | | | 3 | 1x2 | 3,86 | 3,39 | 1,23 |
| | | | 3 | 1x4 | 3,88 | 3,88 | 2,03 |
| 3,0 | 80 | 31 | 1 | 1x2 | 11,58 | 1,13 | 0,00 |
| | | | 1 | 1x4 | 11,65 | 2,19 | 0,00 |
| | | | 2 | 1x2 | 5,79 | 2,77 | 0,52 |
| | | | 2 | 1x4 | 5,83 | 4,14 | 1,03 |
| | | | 3 | 1x2 | 3,86 | 2,96 | 1,01 |
| | | | 3 | 1x4 | 3,88 | 3,88 | 1,63 |

High density scenario

Table 19: Set §1 - Second Round - 3 MHz - High density scenario

| Bandwidth (MHz) | Speed (km/h) | Reuse factor | DL | Throughput (Mbit/s) | | |
|-----------------|--------------|--------------|-----|---------------------|------------------------------|-----------------------------|
| | | | | Cell centre | Smth. 100 m median cell edge | Smth. 100 m worst cell edge |
| 3,0 | 80 | 1 | 2x2 | 7,96 | 0,00 | 0,00 |
| | | 1 | 4x2 | 7,89 | 0,00 | 0,00 |
| | | 2 | 2x2 | 3,98 | 1,48 | 0,00 |
| | | 2 | 4x2 | 3,95 | 1,46 | 0,00 |
| | | 3 | 2x2 | 2,65 | 1,99 | 0,27 |
| | | 3 | 4x2 | 2,63 | 1,96 | 0,29 |

| Bandwidth (MHz) | Speed (km/h) | Tx Power (dBm) | Reuse factor | UL | Throughput (Mbit/s) | | |
|-----------------|--------------|----------------|--------------|-----|---------------------|------------------------------|-----------------------------|
| | | | | | Cell centre | Smth. 100 m median cell edge | Smth. 100 m worst cell edge |
| 3,0 | 80 | 23 | 1 | 1x2 | 11,58 | 0,24 | 0,00 |
| | | | 1 | 1x4 | 11,65 | 0,63 | 0,00 |
| | | | 2 | 1x2 | 5,79 | 1,13 | 0,05 |
| | | | 2 | 1x4 | 5,83 | 1,98 | 0,16 |
| | | | 3 | 1x2 | 3,86 | 1,22 | 0,19 |
| | | | 3 | 1x4 | 3,88 | 2,01 | 0,42 |
| 3,0 | 80 | 26 | 1 | 1x2 | 11,58 | 0,15 | 0,00 |
| | | | 1 | 1x4 | 11,65 | 0,44 | 0,00 |
| | | | 2 | 1x2 | 5,79 | 1,05 | 0,02 |
| | | | 2 | 1x4 | 5,83 | 1,92 | 0,12 |
| | | | 3 | 1x2 | 3,86 | 1,27 | 0,20 |
| | | | 3 | 1x4 | 3,88 | 2,08 | 0,42 |
| 3,0 | 80 | 31 | 1 | 1x2 | 11,58 | 0,02 | 0,00 |
| | | | 1 | 1x4 | 11,65 | 0,17 | 0,00 |
| | | | 2 | 1x2 | 5,79 | 0,96 | 0,00 |
| | | | 2 | 1x4 | 5,83 | 1,62 | 0,04 |
| | | | 3 | 1x2 | 3,86 | 1,23 | 0,16 |
| | | | 3 | 1x4 | 3,88 | 2,03 | 0,40 |

Hilly scenario

Table 20: Set §1 - Second Round - 3 MHz - Hilly scenario

| Bandwidth (MHz) | Speed (km/h) | Reuse factor | DL | Throughput (Mbit/s) | | |
|-----------------|--------------|--------------|-----|---------------------|------------------------------|-----------------------------|
| | | | | Cell centre | Smth. 100 m median cell edge | Smth. 100 m worst cell edge |
| 3,0 | 160 | 1 | 2x2 | 5,90 | 0,00 | 0,00 |
| | | 1 | 4x2 | 5,58 | 0,00 | 0,00 |
| | | 2 | 2x2 | 2,95 | 1,77 | 0,10 |
| | | 2 | 4x2 | 2,79 | 1,74 | 0,08 |
| | | 3 | 2x2 | 1,97 | 1,75 | 0,47 |
| | | 3 | 4x2 | 1,86 | 1,73 | 0,47 |

| Bandwidth (MHz) | Speed (km/h) | Tx Power (dBm) | Reuse factor | UL | Throughput (Mbit/s) | | |
|-----------------|--------------|----------------|--------------|-----|---------------------|------------------------------|-----------------------------|
| | | | | | Cell centre | Smth. 100 m median cell edge | Smth. 100 m worst cell edge |
| 3,0 | 160 | 23 | 1 | 1x2 | 9,66 | 0,00 | 0,00 |
| | | | 1 | 1x4 | 9,71 | 0,00 | 0,00 |
| | | | 2 | 1x2 | 4,83 | 0,90 | 0,01 |
| | | | 2 | 1x4 | 4,86 | 1,56 | 0,11 |
| | | | 3 | 1x2 | 3,22 | 0,93 | 0,13 |
| | | | 3 | 1x4 | 3,24 | 1,52 | 0,31 |
| 3,0 | 160 | 26 | 1 | 1x2 | 9,66 | 0,00 | 0,00 |
| | | | 1 | 1x4 | 9,71 | 0,00 | 0,00 |
| | | | 2 | 1x2 | 4,83 | 0,90 | 0,01 |
| | | | 2 | 1x4 | 4,86 | 1,56 | 0,10 |
| | | | 3 | 1x2 | 3,22 | 1,02 | 0,17 |
| | | | 3 | 1x4 | 3,24 | 1,67 | 0,37 |
| 3,0 | 160 | 31 | 1 | 1x2 | 9,66 | 0,00 | 0,00 |
| | | | 1 | 1x4 | 9,71 | 0,00 | 0,00 |
| | | | 2 | 1x2 | 4,83 | 0,82 | 0,00 |
| | | | 2 | 1x4 | 4,86 | 1,41 | 0,04 |
| | | | 3 | 1x2 | 3,22 | 1,06 | 0,17 |
| | | | 3 | 1x4 | 3,24 | 1,71 | 0,37 |

5.1.3.2.4 Results at 5 MHz

High speed scenario

Table 21: Set §1 - Second Round - 5 MHz - High speed scenario

| Bandwidth (MHz) | Speed (km/h) | Reuse factor | DL | Throughput (Mbit/s) | | |
|-----------------|--------------|--------------|-----|---------------------|------------------------------|-----------------------------|
| | | | | Cell centre | Smth. 100 m median cell edge | Smth. 100 m worst cell edge |
| 5,0 | 350 | 1 | 2x2 | 17,18 | 5,17 | 0,46 |
| | | 1 | 4x2 | 16,07 | 5,19 | 0,48 |
| | | 2 | 2x2 | 8,59 | 8,53 | 4,40 |
| | | 2 | 4x2 | 8,04 | 7,79 | 4,17 |
| | | 3 | 2x2 | 5,73 | 5,73 | 4,87 |
| | | 3 | 4x2 | 5,36 | 5,36 | 4,50 |

| Bandwidth (MHz) | Speed (km/h) | Tx Power (dBm) | Reuse factor | UL | Throughput (Mbit/s) | | |
|-----------------|--------------|----------------|--------------|-----|---------------------|------------------------------|-----------------------------|
| | | | | | Cell centre | Smth. 100 m median cell edge | Smth. 100 m worst cell edge |
| 5,0 | 350 | 23 | 1 | 1x2 | 15,89 | 1,17 | 0,00 |
| | | | 1 | 1x4 | 16,03 | 2,29 | 0,00 |
| | | | 2 | 1x2 | 7,95 | 4,88 | 2,64 |
| | | | 2 | 1x4 | 8,02 | 6,65 | 4,17 |
| | | | 3 | 1x2 | 5,30 | 3,84 | 2,39 |
| | | | 3 | 1x4 | 5,34 | 4,83 | 3,39 |
| 5,0 | 350 | 26 | 1 | 1x2 | 15,89 | 0,77 | 0,00 |
| | | | 1 | 1x4 | 16,03 | 1,51 | 0,00 |
| | | | 2 | 1x2 | 7,95 | 5,08 | 2,83 |
| | | | 2 | 1x4 | 8,02 | 6,87 | 4,39 |
| | | | 3 | 1x2 | 5,30 | 4,09 | 2,75 |
| | | | 3 | 1x4 | 5,34 | 5,15 | 3,77 |
| 5,0 | 350 | 31 | 1 | 1x2 | 15,89 | 0,36 | 0,00 |
| | | | 1 | 1x4 | 16,03 | 0,78 | 0,00 |
| | | | 2 | 1x2 | 7,95 | 5,14 | 2,76 |
| | | | 2 | 1x4 | 8,02 | 6,90 | 4,35 |
| | | | 3 | 1x2 | 5,30 | 4,31 | 3,04 |
| | | | 3 | 1x4 | 5,34 | 5,32 | 4,10 |

Urban scenario

Table 22: Set §1 - Second Round - 5 MHz - Urban scenario

| Bandwidth (MHz) | Speed (km/h) | Reuse factor | DL | Throughput (Mbit/s) | | |
|-----------------|--------------|--------------|-----|---------------------|------------------------------|-----------------------------|
| | | | | Cell centre | Smth. 100 m median cell edge | Smth. 100 m worst cell edge |
| 5,0 | 80 | 1 | 2x2 | 13,27 | 1,77 | 0,00 |
| | | 1 | 4x2 | 13,16 | 1,90 | 0,00 |
| | | 2 | 2x2 | 6,64 | 5,34 | 0,95 |
| | | 2 | 4x2 | 6,58 | 5,24 | 1,01 |
| | | 3 | 2x2 | 4,42 | 4,08 | 1,94 |
| | | 3 | 4x2 | 4,39 | 3,86 | 2,05 |

| Bandwidth (MHz) | Speed (km/h) | Tx Power (dBm) | Reuse factor | UL | Throughput (Mbit/s) | | |
|-----------------|--------------|----------------|--------------|-----|---------------------|------------------------------|-----------------------------|
| | | | | | Cell centre | Smth. 100 m median cell edge | Smth. 100 m worst cell edge |
| 5,0 | 80 | 23 | 1 | 1x2 | 19,24 | 3,44 | 0,00 |
| | | | 1 | 1x4 | 19,37 | 6,16 | 0,03 |
| | | | 2 | 1x2 | 9,62 | 5,71 | 1,54 |
| | | | 2 | 1x4 | 9,68 | 8,51 | 2,64 |
| | | | 3 | 1x2 | 6,41 | 5,60 | 2,14 |
| | | | 3 | 1x4 | 6,46 | 6,46 | 3,55 |
| 5,0 | 80 | 26 | 1 | 1x2 | 19,24 | 3,02 | 0,00 |
| | | | 1 | 1x4 | 19,37 | 5,22 | 0,00 |
| | | | 2 | 1x2 | 9,62 | 5,35 | 1,22 |
| | | | 2 | 1x4 | 9,68 | 7,89 | 2,26 |
| | | | 3 | 1x2 | 6,41 | 5,46 | 1,96 |
| | | | 3 | 1x4 | 6,46 | 6,46 | 3,32 |
| 5,0 | 80 | 31 | 1 | 1x2 | 19,24 | 1,87 | 0,00 |
| | | | 1 | 1x4 | 19,37 | 3,50 | 0,00 |
| | | | 2 | 1x2 | 9,62 | 4,49 | 0,87 |
| | | | 2 | 1x4 | 9,68 | 6,77 | 1,69 |
| | | | 3 | 1x2 | 6,41 | 4,76 | 1,63 |
| | | | 3 | 1x4 | 6,46 | 6,43 | 2,69 |

High density scenario

Table 23: Set §1 - Second Round - 5 MHz - High density scenario

| Bandwidth (MHz) | Speed (km/h) | Reuse factor | DL | Throughput (Mbit/s) | | |
|-----------------|--------------|--------------|-----|---------------------|------------------------------|-----------------------------|
| | | | | Cell centre | Smth. 100 m median cell edge | Smth. 100 m worst cell edge |
| 5,0 | 80 | 1 | 2x2 | 13,27 | 0,00 | 0,00 |
| | | 1 | 4x2 | 13,16 | 0,00 | 0,00 |
| | | 2 | 2x2 | 6,64 | 2,46 | 0,01 |
| | | 2 | 4x2 | 6,58 | 2,44 | 0,00 |
| | | 3 | 2x2 | 4,42 | 3,32 | 0,46 |
| | | 3 | 4x2 | 4,39 | 3,26 | 0,48 |

| Bandwidth (MHz) | Speed (km/h) | Tx Power (dBm) | Reuse factor | UL | Throughput (Mbit/s) | | |
|-----------------|--------------|----------------|--------------|-----|---------------------|------------------------------|-----------------------------|
| | | | | | Cell centre | Smth. 100 m median cell edge | Smth. 100 m worst cell edge |
| 5,0 | 80 | 23 | 1 | 1x2 | 19,24 | 0,36 | 0,00 |
| | | | 1 | 1x4 | 19,37 | 0,87 | 0,00 |
| | | | 2 | 1x2 | 9,62 | 1,64 | 0,04 |
| | | | 2 | 1x4 | 9,68 | 2,86 | 0,18 |
| | | | 3 | 1x2 | 6,41 | 1,66 | 0,21 |
| | | | 3 | 1x4 | 6,46 | 2,75 | 0,59 |
| 5,0 | 80 | 26 | 1 | 1x2 | 19,24 | 0,22 | 0,00 |
| | | | 1 | 1x4 | 19,37 | 0,63 | 0,00 |
| | | | 2 | 1x2 | 9,62 | 1,63 | 0,03 |
| | | | 2 | 1x4 | 9,68 | 2,84 | 0,14 |
| | | | 3 | 1x2 | 6,41 | 1,77 | 0,26 |
| | | | 3 | 1x4 | 6,46 | 2,99 | 0,65 |
| 5,0 | 80 | 31 | 1 | 1x2 | 19,24 | 0,04 | 0,00 |
| | | | 1 | 1x4 | 19,37 | 0,23 | 0,00 |
| | | | 2 | 1x2 | 9,62 | 1,47 | 0,01 |
| | | | 2 | 1x4 | 9,68 | 2,57 | 0,06 |
| | | | 3 | 1x2 | 6,41 | 1,80 | 0,24 |
| | | | 3 | 1x4 | 6,46 | 3,07 | 0,64 |

Hilly scenario

Table 24: Set §1 - Second Round - 5 MHz - Hilly scenario

| Bandwidth (MHz) | Speed (km/h) | Reuse factor | DL | Throughput (Mbit/s) | | |
|-----------------|--------------|--------------|-----|---------------------|------------------------------|-----------------------------|
| | | | | Cell centre | Smth. 100 m median cell edge | Smth. 100 m worst cell edge |
| 5,0 | 160 | 1 | 2x2 | 9,84 | 0,00 | 0,00 |
| | | 1 | 4x2 | 9,29 | 0,00 | 0,00 |
| | | 2 | 2x2 | 4,92 | 2,95 | 0,16 |
| | | 2 | 4x2 | 4,65 | 2,90 | 0,13 |
| | | 3 | 2x2 | 3,28 | 2,90 | 0,78 |
| | | 3 | 4x2 | 3,10 | 2,87 | 0,79 |

| Bandwidth (MHz) | Speed (km/h) | Tx Power (dBm) | Reuse factor | UL | Throughput (Mbit/s) | | |
|-----------------|--------------|----------------|--------------|-----|---------------------|------------------------------|-----------------------------|
| | | | | | Cell centre | Smth. 100 m median cell edge | Smth. 100 m worst cell edge |
| 5,0 | 160 | 23 | 1 | 1x2 | 16,07 | 0,00 | 0,00 |
| | | | 1 | 1x4 | 16,18 | 0,00 | 0,00 |
| | | | 2 | 1x2 | 8,04 | 1,24 | 0,02 |
| | | | 2 | 1x4 | 8,09 | 2,15 | 0,08 |
| | | | 3 | 1x2 | 5,36 | 1,21 | 0,13 |
| | | | 3 | 1x4 | 5,39 | 2,00 | 0,35 |
| 5,0 | 160 | 26 | 1 | 1x2 | 16,07 | 0,00 | 0,00 |
| | | | 1 | 1x4 | 16,18 | 0,00 | 0,00 |
| | | | 2 | 1x2 | 8,04 | 1,30 | 0,03 |
| | | | 2 | 1x4 | 8,09 | 2,24 | 0,11 |
| | | | 3 | 1x2 | 5,36 | 1,36 | 0,19 |
| | | | 3 | 1x4 | 5,39 | 2,18 | 0,50 |
| 5,0 | 160 | 31 | 1 | 1x2 | 16,07 | 0,00 | 0,00 |
| | | | 1 | 1x4 | 16,18 | 0,00 | 0,00 |
| | | | 2 | 1x2 | 8,04 | 1,24 | 0,01 |
| | | | 2 | 1x4 | 8,09 | 2,14 | 0,05 |
| | | | 3 | 1x2 | 5,36 | 1,51 | 0,24 |
| | | | 3 | 1x4 | 5,39 | 2,49 | 0,55 |

A few examples of curves where figures are picked up from are provided in Figure 7. The full set can be found in annex B.

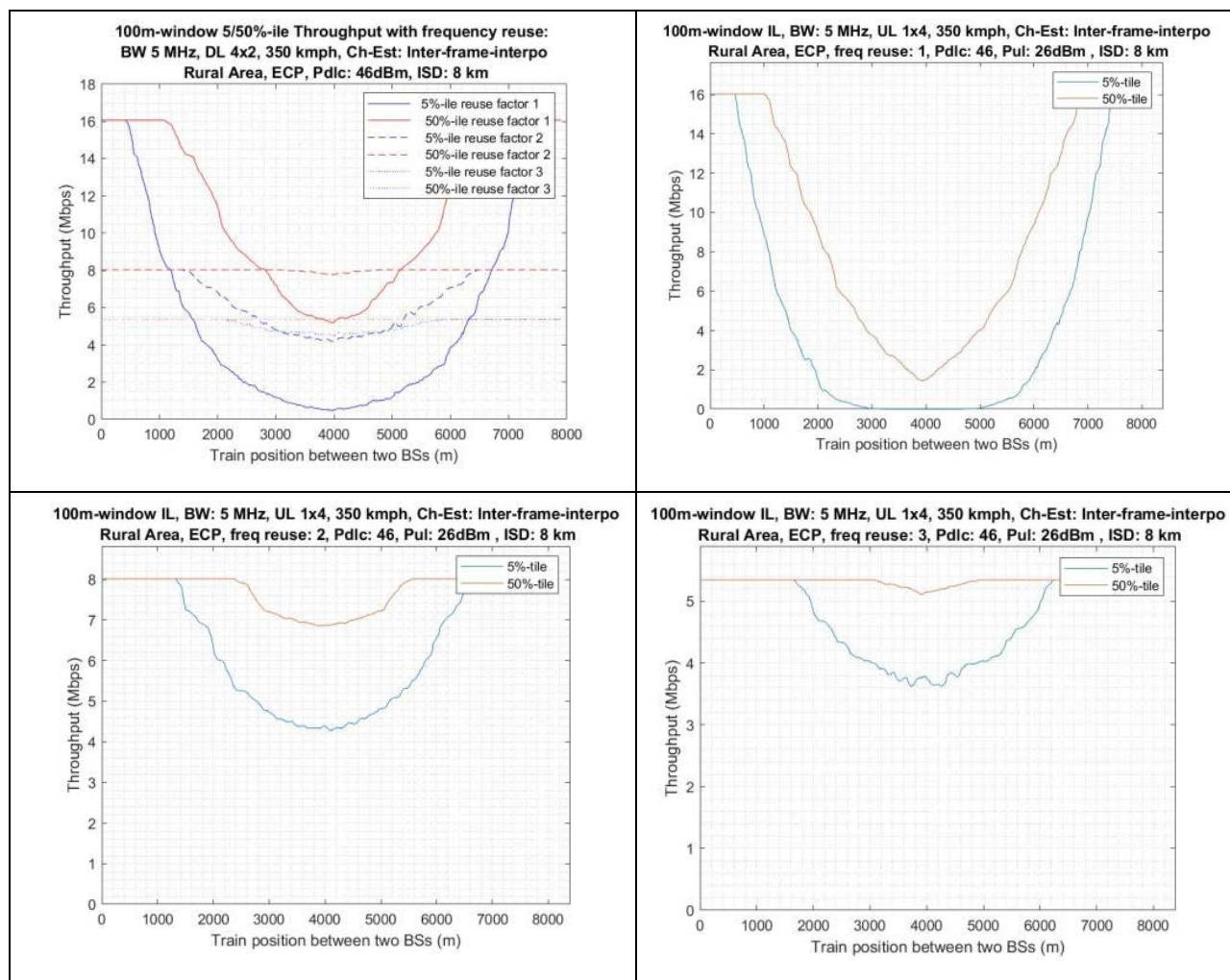

Figure 7: Example of throughput vs distance to base station (second round)

5.1.3.3 Results for 1 900 MHz band

In the following, performance results for different environments, ISDs, UL powers and MIMO schemes are provided. For uplink, double Doppler has been used. Numbers in bold in the tables indicate the best achievable throughput for each configuration.

High speed scenario

Table 25: Downlink Rural Area 8 km ISD

| Speed (km/h) | EIRP (dBm) | Reuse factor | MIMO DL | Throughput (Mbit/s) 50/50 TDD | | | Throughput (Mbit/s) 75/25 TDD | | |
|--------------|------------|--------------|---------|-------------------------------|------------------------------|-----------------------------|-------------------------------|------------------------------|-----------------------------|
| | | | | Cell Centre | Smth. 100 m median cell edge | Smth. 100 m worst cell edge | Cell Centre | Smth. 100 m median cell edge | Smth. 100 m worst cell edge |
| 350 | 63 | 1 | 2x2 | 11,3 | 6,35 | 0 | 5,65 | 3,18 | 0,00 |
| 500 | | 1 | | 7,58 | 5,91 | 0 | 3,79 | 2,96 | 0,00 |
| 350 | | 2 | | 5,65 | 5,61 | 5,29 | 2,83 | 2,81 | 2,65 |
| 500 | | 2 | | 3,79 | 3,79 | 3,79 | 1,90 | 1,90 | 1,90 |
| 350 | | 3 | | 3,77 | 3,76 | 3,72 | 1,89 | 1,88 | 1,86 |
| 500 | | 3 | | 2,53 | 2,53 | 2,53 | 1,27 | 1,27 | 1,27 |
| 350 | 40 | 1 | | 11,3 | 3,84 | 0 | 5,65 | 1,92 | 0,00 |
| 500 | | 1 | | 7,58 | 3,47 | 0 | 3,79 | 1,74 | 0,00 |
| 350 | | 2 | | 5,65 | 3,77 | 1,43 | 2,83 | 1,89 | 0,72 |
| 500 | | 2 | | 3,79 | 3,18 | 1,36 | 1,90 | 1,59 | 0,68 |
| 350 | | 3 | | 3,77 | 2,51 | 1,39 | 1,89 | 1,26 | 0,70 |
| 500 | | 3 | | 2,53 | 2,49 | 1,24 | 1,27 | 1,25 | 0,62 |

For 8 km ISD, for both DL transmit powers, frequency reuse 1 suffers from strong interference. Frequency reuse factor 2 mitigates interference efficiently on cell edge on the expense of reducing the cell center throughput. A cell edge throughput up to 5,29 Mbit/s can be achieved with frequency reuse 2 (63 dBm EIRP and 50/50 TDD). Cell center throughput reduction can be avoided through well-known interference coordination mechanisms (e.g. ICIC).

Using the frequency reuse 2, increasing DL EIRP power from 40 dBm to 63 dBm increases the wanted signal only and the cell edge throughput is significantly increased.

Table 26: Downlink Rural Area 6 km ISD

| Speed (km/h) | EIRP (dBm) | Reuse factor | MIMO DL | Throughput (Mbit/s) 50/50 TDD | | | Throughput (Mbit/s) 75/25 TDD | | |
|--------------|------------|--------------|---------|-------------------------------|------------------------------|-----------------------------|-------------------------------|------------------------------|-----------------------------|
| | | | | Cell Centre | Smth. 100 m median cell edge | Smth. 100 m worst cell edge | Cell Centre | Smth. 100 m median cell edge | Smth. 100 m worst cell edge |
| 350 | 63 | 1 | 2x2 | 11,3 | 6,27 | 0 | 5,65 | 3,14 | 0,00 |
| 500 | | 1 | | 7,58 | 5,75 | 0 | 3,79 | 2,88 | 0,00 |
| 350 | | 2 | | 5,65 | 5,62 | 5,34 | 2,83 | 2,81 | 2,67 |
| 500 | | 2 | | 3,79 | 3,79 | 3,79 | 1,90 | 1,90 | 1,90 |
| 350 | | 3 | | 3,77 | 3,77 | 3,73 | 1,89 | 1,89 | 1,87 |
| 500 | | 3 | | 2,53 | 2,53 | 2,53 | 1,27 | 1,27 | 1,27 |
| 350 | 40 | 1 | | 11,3 | 5,3 | 0 | 5,65 | 2,65 | 0,00 |
| 500 | | 1 | | 7,58 | 4,91 | 0 | 3,79 | 2,46 | 0,00 |
| 350 | | 2 | | 5,65 | 4,47 | 3 | 2,83 | 2,24 | 1,50 |
| 500 | | 2 | | 3,79 | 3,79 | 2,64 | 1,90 | 1,90 | 1,32 |
| 350 | | 3 | | 3,77 | 3,34 | 2,28 | 1,89 | 1,67 | 1,14 |
| 500 | | 3 | | 2,53 | 2,53 | 2,01 | 1,27 | 1,27 | 1,01 |

For 6 km ISD, similar observation concerning interference and its mitigation though frequency reuse 2 can be made.

For 63 dBm very close performance compared to 8 km ISD is observed since the wanted signal power is sufficiently high to reach the performance saturation in both cases. For 40 dBm EIRP power, as expected, a higher throughput is observed for 6 km ISD compared to 8 km ISD.

Table 27: Downlink Rural Area 4 km ISD

| Speed (km/h) | EIRP (dBm) | Reuse factor | MIMO DL | Throughput (Mbit/s) 50/50 TDD | | | Throughput (Mbit/s) 75/25 TDD | | |
|--------------|------------|--------------|---------|-------------------------------|------------------------------|-----------------------------|-------------------------------|------------------------------|-----------------------------|
| | | | | Cell Centre | Smth. 100 m median cell edge | Smth. 100 m worst cell edge | Cell Centre | Smth. 100 m median cell edge | Smth. 100 m worst cell edge |
| 350 | 63 | 1 | 2x2 | 11,3 | 5,83 | 0 | 5,65 | 2,92 | 0,00 |
| 500 | | 1 | | 7,58 | 5,2 | 0 | 3,79 | 2,60 | 0,00 |
| 350 | | 2 | | 5,65 | 5,58 | 3,58 | 2,83 | 2,79 | 1,79 |
| 500 | | 2 | | 3,79 | 3,79 | 3,01 | 1,90 | 1,90 | 1,51 |
| 350 | | 3 | | 3,77 | 3,77 | 3,74 | 1,89 | 1,89 | 1,87 |
| 500 | | 3 | | 2,53 | 2,53 | 2,53 | 1,27 | 1,27 | 1,27 |
| 350 | 40 | 1 | | 11,3 | 5,7 | 0 | 5,65 | 2,85 | 0,00 |
| 500 | | 1 | | 7,58 | 5,13 | 0 | 3,79 | 2,57 | 0,00 |
| 350 | | 2 | | 5,65 | 5,23 | 3,14 | 2,83 | 2,62 | 1,57 |
| 500 | | 2 | | 3,79 | 3,79 | 2,88 | 1,90 | 1,90 | 1,44 |
| 350 | | 3 | | 3,77 | 3,7 | 3,05 | 1,89 | 1,85 | 1,53 |
| 500 | | 3 | | 2,53 | 2,53 | 2,53 | 1,27 | 1,27 | 1,27 |

For 4 km ISD, with 63 dBm DL EIRP, the throughput in frequency reuse 2 is lower compared to 6 and 8 km ISD due to stronger interference. For 40 dBm DL EIRP and 4 km ISD, the cell edge performance is higher compared to 6 and 8 km ISD cases.

It can be concluded that 63 dBm EIRP in frequency reuse 2 is suitable for 8 and 6 km ISD while 40 dBm EIRP is more suitable for 4 km ISD.

The highest achievable throughput in cell centre (best link budget) is only 11,3 Mbit/s because of the high speed. A comparison with low speed (Urban scenario) confirms this interpretation.

Table 28: Uplink Rural Area 8 km ISD

| Speed | Tx Power (dBm) | Reuse factor | MIMO UL | Throughput (Mbit/s) 50/50 TDD | | | Throughput (Mbit/s) 75/25 TDD | | |
|----------|----------------|--------------|---------|-------------------------------|------------------------------|-----------------------------|-------------------------------|------------------------------|-----------------------------|
| | | | | Cell Centre | Smth. 100 m median cell edge | Smth. 100 m worst cell edge | Cell Centre | Smth. 100 m median cell edge | Smth. 100 m worst cell edge |
| 350 km/h | 23 | 1 | 1x1 | 1,53 | 0,35 | 0 | 2,30 | 0,53 | 0,00 |
| | | 1 | 1x2 | 2,14 | 0,63 | 0 | 3,21 | 0,95 | 0,00 |
| | | 1 | 1x4 | 6,48 | 1,29 | 0 | 9,72 | 1,94 | 0,00 |
| | | 2 | 1x1 | 0,77 | 0,32 | 0,08 | 1,16 | 0,48 | 0,12 |
| | | 2 | 1x2 | 1,07 | 0,83 | 0,21 | 1,61 | 1,25 | 0,32 |
| | | 2 | 1x4 | 3,24 | 1,07 | 0,34 | 4,86 | 1,61 | 0,51 |
| | | 3 | 1x1 | 0,51 | 0,23 | 0,09 | 0,77 | 0,35 | 0,14 |
| | | 3 | 1x2 | 0,71 | 0,66 | 0,2 | 1,07 | 0,99 | 0,30 |
| | | 3 | 1x4 | 2,16 | 0,72 | 0,3 | 3,24 | 1,08 | 0,45 |
| | 26 | 1 | 1x1 | 1,53 | 0,43 | 0 | 2,30 | 0,65 | 0,00 |
| | | 1 | 1x2 | 2,14 | 0,67 | 0 | 3,21 | 1,01 | 0,00 |
| | | 1 | 1x4 | 6,48 | 1,71 | 0 | 9,72 | 2,57 | 0,00 |
| | | 2 | 1x1 | 0,77 | 0,34 | 0,16 | 1,16 | 0,51 | 0,24 |
| | | 2 | 1x2 | 1,07 | 0,97 | 0,31 | 1,61 | 1,46 | 0,47 |
| | | 2 | 1x4 | 3,24 | 1,07 | 0,58 | 4,86 | 1,61 | 0,87 |
| | | 3 | 1x1 | 0,51 | 0,3 | 0,15 | 0,77 | 0,45 | 0,23 |
| | | 3 | 1x2 | 0,71 | 0,7 | 0,23 | 1,07 | 1,05 | 0,35 |
| | | 3 | 1x4 | 2,16 | 0,72 | 0,64 | 3,24 | 1,08 | 0,96 |
| | 31 | 1 | 1x1 | 1,53 | 0,52 | 0 | 2,30 | 0,78 | 0,00 |
| | | 1 | 1x2 | 2,14 | 0,87 | 0 | 3,21 | 1,31 | 0,00 |
| | | 1 | 1x4 | 6,48 | 2,02 | 0 | 9,72 | 3,03 | 0,00 |
| | | 2 | 1x1 | 0,77 | 0,6 | 0,29 | 1,16 | 0,90 | 0,44 |
| | | 2 | 1x2 | 1,07 | 1,05 | 0,57 | 1,61 | 1,58 | 0,86 |
| | | 2 | 1x4 | 3,24 | 1,07 | 1,06 | 4,86 | 1,61 | 1,59 |
| | | 3 | 1x1 | 0,51 | 0,39 | 0,22 | 0,77 | 0,59 | 0,33 |
| | | 3 | 1x2 | 0,71 | 0,71 | 0,57 | 1,07 | 1,07 | 0,86 |
| | | 3 | 1x4 | 2,16 | 0,72 | 0,72 | 3,24 | 1,08 | 1,08 |

In Uplink with 8 km ISD, trains may also suffer from strong interference from users on the edge of neighbouring cells. Note that the performance is relatively low in uplink at 350 km/h since channel estimation fails for moderate and high modulation schemes and only low modulation order are feasible. This can also be seen from cell centre performance since maximum achievable throughput is as low as 6,48 Mbit/s even in frequency reuse one where the whole bandwidth is used.

MIMO receive diversity brings very significant gain in cell edge throughput. For a given MIMO scheme, increasing the UL transmit power increases the cell edge throughput (up to 1 Mbit/s for 50/50 UL/DL; MIMO UL 1x4; reuse factor 2 configuration and 1,6 Mbit/s for 75/25 UL/DL; MIMO UL 1x4; reuse factor 2 configuration) for 31 dBm uplink power. 23 dBm uplink power may be insufficient in 1 900 MHz TDD mode.

Table 29: Uplink Rural Area 6 km ISD

| Speed | Tx Power (dBm) | Reuse factor | MIMO UL | Throughput (Mbit/s) 50/50 TDD | | | Throughput (Mbit/s) 75/25 TDD | | |
|----------|----------------|--------------|---------|-------------------------------|------------------------------|-----------------------------|-------------------------------|------------------------------|-----------------------------|
| | | | | Cell Centre | Smth. 100 m median cell edge | Smth. 100 m worst cell edge | Cell Centre | Smth. 100 m median cell edge | Smth. 100 m worst cell edge |
| 350 km/h | 23 | 1 | 1x1 | 1,53 | 0,6 | 0 | 2,30 | 0,90 | 0,00 |
| | | 1 | 1x2 | 2,14 | 1,48 | 0 | 3,21 | 2,22 | 0,00 |
| | | 1 | 1x4 | 6,48 | 2,15 | 0,02 | 9,72 | 3,23 | 0,03 |
| | | 2 | 1x1 | 0,77 | 0,64 | 0,26 | 1,16 | 0,96 | 0,39 |
| | | 2 | 1x2 | 1,07 | 1,06 | 0,42 | 1,61 | 1,59 | 0,63 |
| | | 2 | 1x4 | 3,24 | 1,07 | 1 | 4,86 | 1,61 | 1,50 |
| | | 3 | 1x1 | 0,51 | 0,4 | 0,2 | 0,77 | 0,60 | 0,30 |
| | | 3 | 1x2 | 0,71 | 0,71 | 0,49 | 1,07 | 1,07 | 0,74 |
| | | 3 | 1x4 | 2,16 | 0,72 | 0,72 | 3,24 | 1,08 | 1,08 |
| | 26 | 1 | 1x1 | 1,53 | 0,65 | 0 | 2,30 | 0,98 | 0,00 |
| | | 1 | 1x2 | 2,14 | 1,69 | 0 | 3,21 | 2,54 | 0,00 |
| | | 1 | 1x4 | 6,48 | 2,15 | 0 | 9,72 | 3,23 | 0,00 |
| | | 2 | 1x1 | 0,77 | 0,59 | 0,31 | 1,16 | 0,89 | 0,47 |
| | | 2 | 1x2 | 1,07 | 1,07 | 0,76 | 1,61 | 1,61 | 1,14 |
| | | 2 | 1x4 | 3,24 | 1,07 | 1,07 | 4,86 | 1,61 | 1,61 |
| | | 3 | 1x1 | 0,51 | 0,46 | 0,23 | 0,77 | 0,69 | 0,35 |
| | | 3 | 1x2 | 0,71 | 0,71 | 0,64 | 1,07 | 1,07 | 0,96 |
| | | 3 | 1x4 | 2,16 | 0,72 | 0,72 | 3,24 | 1,08 | 1,08 |
| | 31 | 1 | 1x1 | 1,53 | 0,68 | 0 | 2,30 | 1,02 | 0,00 |
| | | 1 | 1x2 | 2,14 | 1,92 | 0 | 3,21 | 2,88 | 0,00 |
| | | 1 | 1x4 | 6,48 | 2,15 | 0 | 9,72 | 3,23 | 0,00 |
| | | 2 | 1x1 | 0,77 | 0,73 | 0,45 | 1,16 | 1,10 | 0,68 |
| | | 2 | 1x2 | 1,07 | 1,07 | 1,04 | 1,61 | 1,61 | 1,56 |
| | | 2 | 1x4 | 3,24 | 1,07 | 1,07 | 4,86 | 1,61 | 1,61 |
| 3 | | 1x1 | 0,51 | 0,51 | 0,4 | 0,77 | 0,77 | 0,60 | |
| 3 | | 1x2 | 0,71 | 0,71 | 0,71 | 1,07 | 1,07 | 1,07 | |
| 3 | | 1x4 | 2,16 | 0,72 | 0,72 | 3,24 | 1,08 | 1,08 | |

For 6 km ISD, the performance is higher compared to 8 km ISD case because of the lower cell edge distance to base station. Interference mitigation is necessary and similar observations can be made about MIMO receive diversity and UL transmit power.

Table 30: Uplink Rural Area ISD 4 km

| Speed | Tx Power (dBm) | Reuse factor | MIMO UL | Throughput (Mbit/s) 50/50 TDD | | | Throughput (Mbit/s) 75/25 TDD | | |
|----------|----------------|--------------|---------|-------------------------------|------------------------------|-----------------------------|-------------------------------|------------------------------|-----------------------------|
| | | | | Cell Centre | Smth. 100 m median cell edge | Smth. 100 m worst cell edge | Cell Centre | Smth. 100 m median cell edge | Smth. 100 m worst cell edge |
| 350 km/h | 23 | 1 | 1x1 | 1,53 | 1,26 | 0,04 | 2,30 | 1,89 | 0,06 |
| | | 1 | 1x2 | 2,14 | 2,12 | 0,19 | 3,21 | 3,18 | 0,29 |
| | | 1 | 1x4 | 6,48 | 2,15 | 0,54 | 9,72 | 3,23 | 0,81 |
| | | 2 | 1x1 | 0,77 | 0,76 | 0,4 | 1,16 | 1,14 | 0,60 |
| | | 2 | 1x2 | 1,07 | 1,07 | 1,03 | 1,61 | 1,61 | 1,55 |
| | | 2 | 1x4 | 3,24 | 1,07 | 1,07 | 4,86 | 1,61 | 1,61 |
| | | 3 | 1x1 | 0,51 | 0,51 | 0,4 | 0,77 | 0,77 | 0,60 |
| | | 3 | 1x2 | 0,71 | 0,71 | 0,71 | 1,07 | 1,07 | 1,07 |
| | 26 | 1 | 1x1 | 1,53 | 1,21 | 0,02 | 2,30 | 1,82 | 0,03 |
| | | 1 | 1x2 | 2,14 | 2,13 | 0,16 | 3,21 | 3,20 | 0,24 |
| | | 1 | 1x4 | 6,48 | 2,15 | 0,52 | 9,72 | 3,23 | 0,78 |
| | | 2 | 1x1 | 0,77 | 0,77 | 0,64 | 1,16 | 1,16 | 0,96 |
| | | 2 | 1x2 | 1,07 | 1,07 | 1,06 | 1,61 | 1,61 | 1,59 |
| | | 2 | 1x4 | 3,24 | 1,07 | 1,07 | 4,86 | 1,61 | 1,61 |
| | | 3 | 1x1 | 0,51 | 0,51 | 0,44 | 0,77 | 0,77 | 0,66 |
| | | 3 | 1x2 | 0,71 | 0,71 | 0,71 | 1,07 | 1,07 | 1,07 |
| | 31 | 1 | 1x1 | 1,53 | 1,19 | 0 | 2,30 | 1,79 | 0,00 |
| | | 1 | 1x2 | 2,14 | 2,13 | 0 | 3,21 | 3,20 | 0,00 |
| | | 1 | 1x4 | 6,48 | 2,15 | 0,05 | 9,72 | 3,23 | 0,08 |
| | | 2 | 1x1 | 0,77 | 0,77 | 0,59 | 1,16 | 1,16 | 0,89 |
| | | 2 | 1x2 | 1,07 | 1,07 | 1,07 | 1,61 | 1,61 | 1,61 |
| | | 2 | 1x4 | 3,24 | 1,07 | 1,07 | 4,86 | 1,61 | 1,61 |
| | | 3 | 1x1 | 0,51 | 0,51 | 0,51 | 0,77 | 0,77 | 0,77 |
| | | 3 | 1x2 | 0,71 | 0,71 | 0,71 | 1,07 | 1,07 | 1,07 |
| | 3 | 1x4 | 2,16 | 0,72 | 0,72 | 3,24 | 1,08 | 1,08 | |

For 4 km ISD, highest throughput performance can be reached compared to higher ISD cases (6 and 8 km) even for 23 dBm uplink transmit power. Higher uplink power does not bring gain although higher SINR can be achieved. This is explained by the maximum achievable throughput since only one low order modulation is feasible at high speed.

Urban scenario

Table 31: Downlink Urban 2 km ISD

| Speed | EIRP (dBm) | Reuse factor | MIMO DL | Throughput (Mbit/s) 50/50 TDD | | | Throughput (Mbit/s) 75/25 TDD | | |
|---------|------------|--------------|---------|-------------------------------|------------------------------|-----------------------------|-------------------------------|------------------------------|-----------------------------|
| | | | | Cell Centre | Smth. 100 m median cell edge | Smth. 100 m worst cell edge | Cell Centre | Smth. 100 m median cell edge | Smth. 100 m worst cell edge |
| 80 km/h | 63 | 1 | 2x2 | 20,52 | 4,44 | 0 | 10,26 | 2,22 | 0,00 |
| | | 2 | | 10,26 | 8,89 | 2,04 | 5,13 | 4,45 | 1,02 |
| | | 3 | | 6,84 | 6,84 | 2,72 | 3,42 | 3,42 | 1,36 |
| | 40 | 1 | | 20,52 | 3,77 | 0 | 10,26 | 1,89 | 0,00 |
| | | 2 | | 10,26 | 6,27 | 1,54 | 5,13 | 3,14 | 0,77 |
| | | 3 | | 6,84 | 5,81 | 2,08 | 3,42 | 2,91 | 1,04 |

In urban scenario (ISD 2 km), interference is very high and frequency reuse 3 provides the highest cell edge performance. With this reuse factor, using 63 dBm efficiently increases wanted signal and a higher performance can be observed compared to 40 dBm EIRP. The throughput can be much higher compared to high speed scenario (rural) since the receiver tolerates Doppler effect at 80 km/h. Maximum achievable throughput (cell centre) in reuse 1 is around 20 Mbit/s.

Table 32: Uplink Urban 2 km ISD

| Speed | Tx Power (dBm) | Reuse factor | MIMO UL | Throughput (Mbit/s) 50/50 TDD | | | Throughput (Mbit/s) 75/25 TDD | | |
|---------|----------------|--------------|---------|-------------------------------|------------------------------|-----------------------------|-------------------------------|------------------------------|-----------------------------|
| | | | | Cell Centre | Smth. 100 m median cell edge | Smth. 100 m worst cell edge | Cell Centre | Smth. 100 m median cell edge | Smth. 100 m worst cell edge |
| 80 km/h | 23 | 1 | 1x1 | 4,97 | 0,85 | 0 | 7,46 | 1,28 | 0,00 |
| | | 1 | 1x2 | 6,41 | 1,99 | 0 | 9,62 | 2,99 | 0,00 |
| | | 1 | 1x4 | 6,42 | 3,36 | 0 | 9,63 | 5,04 | 0,00 |
| | | 2 | 1x1 | 2,48 | 1,32 | 0,15 | 3,72 | 1,98 | 0,23 |
| | | 2 | 1x2 | 3,2 | 2,22 | 0,35 | 4,80 | 3,33 | 0,53 |
| | | 2 | 1x4 | 3,21 | 2,51 | 1 | 4,82 | 3,77 | 1,50 |
| | | 3 | 1x1 | 1,66 | 1,12 | 0,29 | 2,49 | 1,68 | 0,44 |
| | | 3 | 1x2 | 2,14 | 1,66 | 0,67 | 3,21 | 2,49 | 1,01 |
| | 3 | 1x4 | 2,14 | 2,08 | 1,14 | 3,21 | 3,12 | 1,71 | |
| | 26 | 1 | 1x1 | 4,97 | 0,75 | 0 | 7,46 | 1,13 | 0,00 |
| | | 1 | 1x2 | 6,41 | 1,86 | 0 | 9,62 | 2,79 | 0,00 |
| | | 1 | 1x4 | 6,42 | 3,12 | 0 | 9,63 | 4,68 | 0,00 |
| | | 2 | 1x1 | 2,48 | 1,4 | 0,16 | 3,72 | 2,10 | 0,24 |
| | | 2 | 1x2 | 3,2 | 2,31 | 0,39 | 4,80 | 3,47 | 0,59 |
| | | 2 | 1x4 | 3,21 | 2,52 | 1,02 | 4,82 | 3,78 | 1,53 |
| | | 3 | 1x1 | 1,66 | 1,16 | 0,41 | 2,49 | 1,74 | 0,62 |
| | | 3 | 1x2 | 2,14 | 1,66 | 0,72 | 3,21 | 2,49 | 1,08 |
| | 3 | 1x4 | 2,14 | 2,13 | 1,2 | 3,21 | 3,20 | 1,80 | |
| | 31 | 1 | 1x1 | 4,97 | 0,41 | 0 | 7,46 | 0,62 | 0,00 |
| | | 1 | 1x2 | 6,41 | 1,23 | 0 | 9,62 | 1,85 | 0,00 |
| | | 1 | 1x4 | 6,42 | 2,13 | 0 | 9,63 | 3,20 | 0,00 |
| | | 2 | 1x1 | 2,48 | 1,39 | 0,12 | 3,72 | 2,09 | 0,18 |
| | | 2 | 1x2 | 3,2 | 2,3 | 0,32 | 4,80 | 3,45 | 0,48 |
| | | 2 | 1x4 | 3,21 | 2,51 | 0,92 | 4,82 | 3,77 | 1,38 |
| 3 | | 1x1 | 1,66 | 1,25 | 0,48 | 2,49 | 1,88 | 0,72 | |
| 3 | | 1x2 | 2,14 | 1,66 | 0,82 | 3,21 | 2,49 | 1,23 | |
| 3 | 1x4 | 2,14 | 2,14 | 1,33 | 3,21 | 3,21 | 2,00 | | |

Frequency reuse 3 offers the higher cell edge performance. In addition, significant gains are observed by using MIMO receive diversity and higher uplink power. Compared to DL, the throughput in UL is also limited by the speed since channel estimation with a double Doppler fails when moderate to high modulation schemes are used.

High density scenario

Table 33: Downlink high density 4 km ISD

| Speed | Tx Power (dBm) | Reuse factor | MIMO DL | Throughput (Mbit/s) 50/50 TDD | | | Throughput (Mbit/s) 75/25 TDD | | |
|---------|----------------|--------------|---------|-------------------------------|------------------------------|-----------------------------|-------------------------------|------------------------------|-----------------------------|
| | | | | Cell Centre | Smth. 100 m median cell edge | Smth. 100 m worst cell edge | Cell Centre | Smth. 100 m median cell edge | Smth. 100 m worst cell edge |
| 80 km/h | 63 | 1 | 2x2 | 20,52 | 3,84 | 0 | 10,26 | 1,92 | 0,00 |
| | | 2 | | 10,26 | 8,56 | 1,75 | 5,13 | 4,28 | 0,88 |
| | | 3 | | 6,84 | 6,84 | 2,79 | 3,42 | 3,42 | 1,40 |
| | 40 | 1 | | 20,52 | 1,09 | 0 | 10,26 | 0,55 | 0,00 |
| | | 2 | | 10,26 | 2,69 | 0,2 | 5,13 | 1,35 | 0,10 |
| | | 3 | | 6,84 | 2,19 | 0,2 | 3,42 | 1,10 | 0,10 |

For 4 km ISD in urban high density scenario, 40 dBm EIRP cannot be used as the link will be noise limited and such low EIRP power is not sufficient. 63 dBm EIRP with interference mitigated by a frequency reuse scheme 2 or 3 significantly improve throughput performance at cell edge. There is no significant degradation caused by speed.

Table 34: Uplink high density 4 km ISD

| Speed | Tx Power (dBm) | Reuse factor | MIMO UL | Throughput (Mbit/s) 50/50 TDD | | | Throughput (Mbit/s) 75/25 TDD | | |
|---------|----------------|--------------|---------|-------------------------------|------------------------------|-----------------------------|-------------------------------|------------------------------|-----------------------------|
| | | | | Cell Centre | Smth. 100 m median cell edge | Smth. 100 m worst cell edge | Cell Centre | Smth. 100 m median cell edge | Smth. 100 m worst cell edge |
| 80 km/h | 23 | 1 | 1x1 | 4,97 | 0,09 | 0 | 7,46 | 0,14 | 0,00 |
| | | 1 | 1x2 | 6,41 | 0,34 | 0 | 9,62 | 0,51 | 0,00 |
| | | 1 | 1x4 | 6,42 | 0,77 | 0 | 9,63 | 1,16 | 0,00 |
| | | 2 | 1x1 | 2,48 | 0,25 | 0 | 3,72 | 0,38 | 0,00 |
| | | 2 | 1x2 | 3,2 | 0,72 | 0 | 4,80 | 1,08 | 0,00 |
| | | 2 | 1x4 | 3,21 | 1,19 | 0,01 | 4,82 | 1,79 | 0,02 |
| | | 3 | 1x1 | 1,66 | 0,29 | 0 | 2,49 | 0,44 | 0,00 |
| | | 3 | 1x2 | 2,14 | 0,68 | 0 | 3,21 | 1,02 | 0,00 |
| | | 3 | 1x4 | 2,14 | 1,15 | 0,07 | 3,21 | 1,73 | 0,11 |
| | 26 | 1 | 1x1 | 4,97 | 0,13 | 0 | 7,46 | 0,20 | 0,00 |
| | | 1 | 1x2 | 6,41 | 0,37 | 0 | 9,62 | 0,56 | 0,00 |
| | | 1 | 1x4 | 6,42 | 0,84 | 0 | 9,63 | 1,26 | 0,00 |
| | | 2 | 1x1 | 2,48 | 0,34 | 0 | 3,72 | 0,51 | 0,00 |
| | | 2 | 1x2 | 3,2 | 0,9 | 0 | 4,80 | 1,35 | 0,00 |
| | | 2 | 1x4 | 3,21 | 1,48 | 0,06 | 4,82 | 2,22 | 0,09 |
| | | 3 | 1x1 | 1,66 | 0,45 | 0,01 | 2,49 | 0,68 | 0,02 |
| | | 3 | 1x2 | 2,14 | 0,73 | 0,07 | 3,21 | 1,10 | 0,11 |
| | | 3 | 1x4 | 2,14 | 1,21 | 0,19 | 3,21 | 1,82 | 0,29 |
| | 31 | 1 | 1x1 | 4,97 | 0,13 | 0 | 7,46 | 0,20 | 0,00 |
| | | 1 | 1x2 | 6,41 | 0,37 | 0 | 9,62 | 0,56 | 0,00 |
| | | 1 | 1x4 | 6,42 | 0,84 | 0 | 9,63 | 1,26 | 0,00 |
| | | 2 | 1x1 | 2,48 | 0,51 | 0 | 3,72 | 0,77 | 0,00 |
| | | 2 | 1x2 | 3,2 | 1,04 | 0,04 | 4,80 | 1,56 | 0,06 |
| | | 2 | 1x4 | 3,21 | 1,75 | 0,21 | 4,82 | 2,63 | 0,32 |
| | | 3 | 1x1 | 1,66 | 0,57 | 0,05 | 2,49 | 0,86 | 0,08 |
| | | 3 | 1x2 | 2,14 | 1,04 | 0,17 | 3,21 | 1,56 | 0,26 |
| | | 3 | 1x4 | 2,14 | 1,58 | 0,47 | 3,21 | 2,37 | 0,71 |

In uplink urban high density scenario (4 km ISD), very limited performance is observed even with the use of MIMO receive diversity and higher uplink power. The highest cell edge performance is 470 kbit/s. This low throughput is reached at 31 dBm uplink power., and indicates that 4 km ISD would not be feasible in Urban environment.

Hilly scenario

Table 35: Downlink hilly 8 km ISD

| Speed | EIRP (dBm) | Reuse factor | MIMO DL | Throughput (Mbit/s) 50/50 TDD | | | Throughput (Mbit/s) 75/25 TDD | | |
|----------|------------|--------------|---------|-------------------------------|------------------------------|-----------------------------|-------------------------------|------------------------------|-----------------------------|
| | | | | Cell Centre | Smth. 100 m median cell edge | Smth. 100 m worst cell edge | Cell Centre | Smth. 100 m median cell edge | Smth. 100 m worst cell edge |
| 350 km/h | 63 | 1 | 2x2 | 14,78 | 1,32 | 0 | 7,39 | 0,66 | 0 |
| | | 2 | | 7,39 | 6,81 | 3,75 | 3,695 | 3,405 | 1,875 |
| | | 3 | | 4,93 | 4,54 | 3,98 | 2,465 | 2,27 | 1,99 |
| | 40 | 1 | | 14,78 | 0,35 | 0 | 7,39 | 0,175 | 0 |
| | | 2 | | 7,39 | 1,33 | 0 | 3,695 | 0,665 | 0 |
| | | 3 | | 4,93 | 1,41 | 0,05 | 2,465 | 0,705 | 0,025 |

In Hilly scenario, only 63 dBm EIRP is feasible and shows a cell edge performance up to 4 Mbit/s with frequency reuse 3 and 50/50 TDD configuration. The maximum delay spread in hilly scenario is high but does not seem to be the limiting factor in downlink since downlink reference signals are distributed on 4 symbols in two time slots. Some of the high order modulation schemes remain feasible and the maximum achievable throughput at cell center is 14,7 Mbit/s. 40 dBm downlink EIRP does not guarantee significant data throughput on cell edge.

Table 36: Uplink hilly 8 km ISD

| Speed | Tx Power (dBm) | Reuse factor | MIMO UL | Throughput (Mbit/s) 50/50 TDD | | | Throughput (Mbit/s) 75/25 TDD | | | |
|----------|----------------|--------------|---------|-------------------------------|------------------------------|-----------------------------|-------------------------------|------------------------------|-----------------------------|------|
| | | | | Cell Centre | Smth. 100 m median cell edge | Smth. 100 m worst cell edge | Cell Centre | Smth. 100 m median cell edge | Smth. 100 m worst cell edge | |
| 350 km/h | 23 | 1 | 1x1 | 4,98 | 0 | 0 | 7,47 | 0,00 | 0,00 | |
| | | 1 | 1x2 | 6,42 | 0,01 | 0 | 9,63 | 0,02 | 0,00 | |
| | | 1 | 1x4 | 6,42 | 0,22 | 0 | 9,63 | 0,33 | 0,00 | |
| | | 2 | 1x1 | 2,49 | 0,08 | 0 | 3,74 | 0,12 | 0,00 | |
| | | 2 | 1x2 | 3,21 | 0,28 | 0 | 4,82 | 0,42 | 0,00 | |
| | | 2 | 1x4 | 3,21 | 0,83 | 0 | 4,82 | 1,25 | 0,00 | |
| | | 3 | 1x1 | 1,66 | 0,12 | 0 | 2,49 | 0,18 | 0,00 | |
| | | 3 | 1x2 | 2,14 | 0,34 | 0 | 3,21 | 0,51 | 0,00 | |
| | | 3 | 1x4 | 2,14 | 0,7 | 0 | 3,21 | 1,05 | 0,00 | |
| | | 26 | 1 | 1x1 | 4,98 | 0 | 0 | 7,47 | 0,00 | 0,00 |
| | | | 1 | 1x2 | 6,42 | 0,03 | 0 | 9,63 | 0,05 | 0,00 |
| | | | 1 | 1x4 | 6,42 | 0,42 | 0 | 9,63 | 0,63 | 0,00 |
| | | | 2 | 1x1 | 2,49 | 0,16 | 0 | 3,74 | 0,24 | 0,00 |
| | | | 2 | 1x2 | 3,21 | 0,44 | 0 | 4,82 | 0,66 | 0,00 |
| | | | 2 | 1x4 | 3,21 | 1,03 | 0 | 4,82 | 1,55 | 0,00 |
| | | | 3 | 1x1 | 1,66 | 0,17 | 0 | 2,49 | 0,26 | 0,00 |
| | | | 3 | 1x2 | 2,14 | 0,56 | 0 | 3,21 | 0,84 | 0,00 |
| | | 3 | 1x4 | 2,14 | 0,86 | 0,02 | 3,21 | 1,29 | 0,03 | |
| | | 31 | 1 | 1x1 | 4,98 | 0,02 | 0 | 7,47 | 0,03 | 0,00 |
| | | | 1 | 1x2 | 6,42 | 0,12 | 0 | 9,63 | 0,18 | 0,00 |
| | | | 1 | 1x4 | 6,42 | 0,54 | 0 | 9,63 | 0,81 | 0,00 |
| | | | 2 | 1x1 | 2,49 | 0,31 | 0 | 3,74 | 0,47 | 0,00 |
| | | | 2 | 1x2 | 3,21 | 0,93 | 0,01 | 4,82 | 1,40 | 0,02 |
| | | | 2 | 1x4 | 3,21 | 1,46 | 0,16 | 4,82 | 2,19 | 0,24 |
| | 3 | | 1x1 | 1,66 | 0,38 | 0,01 | 2,49 | 0,57 | 0,02 | |
| | 3 | | 1x2 | 2,14 | 0,71 | 0,08 | 3,21 | 1,07 | 0,12 | |
| | 3 | 1x4 | 2,14 | 1,18 | 0,22 | 3,21 | 1,77 | 0,33 | | |

In uplink Hilly scenario, degradation caused by high speed (double Doppler) and the relatively high ISD (8 km) make this scenario not feasible. Even with the uplink transmit power of 31 dBm and 4 Rx antennas the cell edge throughput remains at 0,22 Mbit/s for 50/50 TDD mode. In addition, the maximum achievable throughput in cell center is 4,98 Mbit/s with the 10 MHz allocated and a 50/50 UL/DL configuration. The uplink performance in Hilly is mainly limited by high delay spread and high speed that impact the channel estimation. Indeed, LTE uplink reference signals are located in symbols 4 and 11 only and this cannot cope with the fast channel variations.

5.1.4 Notes and remarks

5.1.4.1 Notes and remarks on first round of results (900 MHz band)

Interference from neighbouring cells

Interference from neighbouring cells explains the low performance obtained for *worst cell edge* metric. Indeed, neighbouring cells are assumed to have a 100 % cell load, which is a pessimistic assumption. The impact on Urban scenario throughput performance is particularly visible, due to a smaller cell size compared to other scenarios. Antenna tilt and interference mitigation techniques should greatly improve the results.

Antenna tilt

An antenna down tilt of 3 degrees has been taken for all scenarios. However, in Urban scenarios, an antenna tilt of 5 degrees may provide better throughput at cell edge for frequency reuse 2 and 3 patterns, as shown in Table 37.

Table 37: UL Throughput for Urban scenario with an antenna tilt of 5° and 1,4 MHz bandwidth

| Speed (km/h) | UL | Reuse factor | Throughput (Mbit/s) | | |
|--------------|-----|--------------|---------------------|------------------|-----------------|
| | | | Cell centre | Median cell edge | Worst cell edge |
| 80 | 1x2 | 2 | 2,20 | 0,70 | 0,05 |
| 80 | 1x4 | 2 | 2,20 | 1,13 | 0,10 |
| 80 | 1x2 | 3 | 1,40 | 0,80 | 0,15 |
| 80 | 1x4 | 3 | 1,40 | 1,25 | 0,25 |

Shadowing

The large scale shadowing is simulated with a log-normal distribution having a standard deviation of 4 dB in Rural model, and 8 dB for Urban and Hilly models. In the 5 %-tile curves, this may correspond to shadowing values that can reach 8 dB (Rural) and 16 dB (Urban and Hilly).

Doppler impact

Under the assumptions of the present document, Doppler has not a big impact on throughput performances compared to other factors as interferences, neither in UL nor in DL. This is due to the relative low frequency band, the effect of directive antennas, and the inclusion in the channel estimation at receiver side of a time-interpolation between consecutive subframes.

Uplink vs. downlink performances

It can be noticed that uplink and downlink throughputs are almost the same for rural and urban deployments. For hilly, the uplink throughput is even much higher than the downlink throughput.

Indeed, interferences in DL are in average higher than interferences in UL, due to less transmit power in UL compared to DL and due to the varying position on the interfering trains.

Moreover, UL MIMO scheme strongly relies on receive diversity: Having 4 antennas in reception (e.g. UL in 1x4) provides a SNR gain of 3 dB compared to having 2 antennas in reception (all DL schemes). In addition, Reference Signals (pilot patterns) have higher density in UL than in DL, leading to have an UL channel estimation more robust for high MCS.

For hilly, the channel is characterized by a very high frequency selectivity (the max delay spread is 20 μ s, which is higher than the length of the extended cyclic prefix with a coherence bandwidth of 50 KHz). UL channel estimation is more robust than in DL in these conditions: In UL, the 64 QAM can be used at cell centre, which is no longer the case for the DL of hilly terrain channel.

5.1.4.2 Notes and remarks on second round of results (900 MHz band)

Impact of throughput smoothing over distance

Median cell edge and worst cell edge throughput values are computed over a position sliding window of 100 m, to limit the impact of deep shadowing on throughput metric. However, since in the simulations the shadowing is correlated over the train position, the difference between *Smth. 100 m* metrics and not smoothed metrics is limited, as shown in Table 38 for high speed scenario.

Table 38: Comparison between Smoothed 100 m and non-smoothed throughput metrics

| Bandwidth (MHz) | Speed (km/h) | Reuse factor | DL | Throughput (Mbit/s) | | | | |
|-----------------|--------------|--------------|-----|---------------------|------------------------------|-----------------------------|------------------|-----------------|
| | | | | Cell centre | Smth. 100 m median cell edge | Smth. 100 m worst cell edge | Median cell edge | Worst cell edge |
| 5,0 | 350 | 1 | 2x2 | 17,18 | 5,17 | 0,46 | 5,23 | 0,34 |
| | | 1 | 4x2 | 16,07 | 5,19 | 0,48 | 5,27 | 0,34 |
| | | 2 | 2x2 | 8,59 | 8,53 | 4,40 | 8,57 | 4,47 |
| | | 2 | 4x2 | 8,04 | 7,79 | 4,17 | 7,90 | 4,21 |
| | | 3 | 2x2 | 5,73 | 5,73 | 4,87 | 5,73 | 4,90 |
| | | 3 | 4x2 | 5,36 | 5,36 | 4,50 | 5,36 | 4,55 |

| Bandwidth (MHz) | Speed (km/h) | Tx Power (dBm) | Reuse factor | UL | Throughput (Mbit/s) | | | | |
|-----------------|--------------|----------------|--------------|-----|---------------------|------------------------------|-----------------------------|------------------|-----------------|
| | | | | | Cell centre | Smth. 100 m median cell edge | Smth. 100 m worst cell edge | Median cell edge | Worst cell edge |
| 5,0 | 350 | 23 | 1 | 1x2 | 15,89 | 1,17 | 0,00 | 1,15 | 0,00 |
| | | | 1 | 1x4 | 16,03 | 2,29 | 0,00 | 2,24 | 0,00 |
| | | | 2 | 1x2 | 7,95 | 4,88 | 2,64 | 4,90 | 2,58 |
| | | | 2 | 1x4 | 8,02 | 6,65 | 4,17 | 6,68 | 4,02 |
| | | | 3 | 1x2 | 5,30 | 3,84 | 2,39 | 3,85 | 2,33 |
| | | | 3 | 1x4 | 5,34 | 4,83 | 3,39 | 4,84 | 3,34 |
| 5,0 | 350 | 26 | 1 | 1x2 | 15,89 | 0,77 | 0,00 | 0,76 | 0,00 |
| | | | 1 | 1x4 | 16,03 | 1,51 | 0,00 | 1,50 | 0,00 |
| | | | 2 | 1x2 | 7,95 | 5,08 | 2,83 | 5,13 | 2,64 |
| | | | 2 | 1x4 | 8,02 | 6,87 | 4,39 | 6,89 | 4,18 |
| | | | 3 | 1x2 | 5,30 | 4,09 | 2,75 | 4,07 | 2,73 |
| | | | 3 | 1x4 | 5,34 | 5,15 | 3,77 | 5,13 | 3,73 |
| 5,0 | 350 | 31 | 1 | 1x2 | 15,89 | 0,36 | 0,00 | 0,35 | 0,00 |
| | | | 1 | 1x4 | 16,03 | 0,78 | 0,00 | 0,75 | 0,00 |
| | | | 2 | 1x2 | 7,95 | 5,14 | 2,76 | 5,13 | 2,68 |
| | | | 2 | 1x4 | 8,02 | 6,90 | 4,35 | 6,89 | 4,28 |
| | | | 3 | 1x2 | 5,30 | 4,31 | 3,04 | 4,28 | 2,98 |
| | | | 3 | 1x4 | 5,34 | 5,32 | 4,10 | 5,30 | 4,05 |

UL Tx power

The benefit of increasing the UL Tx power is limited, and may even lead to a decrease in throughput at cell edge. Indeed, the best throughput results for *worst cell edge* throughput are obtained for an UL Tx power of 23 or 26 dBm except for Hilly scenario at 5 MHz. Peak values are not affected by the added power since at cell centre, the system operates already at its maximum achievable capacity.

Under the assumptions taken in the present document, limiting the interference level from adjacent cells is always necessary. A frequency reuse 3 scheme provides the better results for *worst cell edge* metric, except for some UL cases where a frequency reuse 2 could be enough. Regarding the *median cell edge* metric, best results are obtained for a frequency reuse 2 schemes in most of the cases, the reuse 3 schemes providing better results in high density scenario.

3 MHz bandwidth

In high speed scenario, the peak throughput can reach almost 10 MBit/s in DL and in UL (frequency reuse 1) at cell centre, and almost 3 MBit/s in DL and UL could be expected as minimum guaranteed bit rate at cell edge.

For Urban scenario, peak DL throughput could reach 8 Mbit/s, and 1,2 Mbit/s can be obtained as DL minimum guaranteed throughput. In UL, up to 11 MBit/s could be expected at cell centre, and around 2 Mbit/s for minimum guaranteed value (frequency reuse 3, 1x4, 23 dBm Tx power).

High density scenario experiences more interferences, leading to lower minimum guaranteed throughputs: They drop down to 0,3 Mbit/s in DL (frequency reuse 3) and 0,5 in UL (frequency reuse 3, 1x4, 26 dBm).

Hilly shows the worst radio conditions. Throughput performance could be up to 6 MBit/s in peak DL, for 0,5 Mbit/s minimum guaranteed value. In UL, peak values could reach almost 10 Mbit/s, but minimum guaranteed value drop to 0,4 MBit/s.

5 MHz bandwidth

Results for 5 MHz bandwidth are rather proportional to the bandwidth compared to results obtained at 3 MHz.

In high speed scenario, peak DL throughput is around 17 Mbit/s, while minimum guaranteed value is about 5 Mbit/s (frequency reuse 3). In UL, results are quite equivalent, with 16 Mbit/s for peak value, and around 4,5 MBit/s as minimum guaranteed throughput (frequency reuse 2, 1x4, 26 dBm Tx power).

In Urban scenario, peak DL falls to 13 MBit/s, and minimum guaranteed throughput to 2 MBit/s (frequency reuse 3). In UL, peak throughput is at 19 MBit/s and minimum guaranteed value around 3,5 MBit/s (frequency reuse 3, 1x4, 23 dBm Tx power).

For high density scenario, peak throughputs are similar to urban case, but minimum guaranteed throughputs are lower, 0,5 Mbit/s in DL (frequency reuse 3) and 0,65 Mbit/s in UL (frequency reuse 3, 1x4, 36 dBm).

For Hilly scenario, peak DL is below 10 MBit/s and peak UL at 16 MBit/s, while minimum guaranteed values are 0,8 MBit/s in DL (frequency reuse 3) and 0,55 MBit/s in UL (frequency reuse 3, 1x4, 31 dBm Tx power).

5.1.4.3 Notes and remarks for results in 1 900 MHz band

Some comments are provided within the clauses providing the results (clause 5.1.3.3).

The path loss in urban scenarios is much more severe than the one used for rural (around 15 dB for the same distance), due to the radio environment and the height of the antenna (35 m in rural vs 20 m in urban).

The throughput in cell centre is not sensitive to the different frequency reuse factors because the wanted signal in cell centre remains much higher than interference in all cases. Even in the case of reuse 1 where interference is the highest, the resulting SINR remains above the saturation SINR value (above which maximum throughput is reached).

5.2 Results set 2 (900 MHz band)

5.2.1 Description

5.2.1.1 Lab setup high level description

A system level simulation is proposed based on an RF lab with eNodeBs in band 8 or band 20. Advantage of RF lab based approach is that all cell topology methods (i.e. CoMP, MIMO) can be implemented as part of the simulation. It operates at '*Hardware simulation and laboratory test reference point*' as defined in Figure 1.

Lab setup includes (see Figure 8):

- 2 eNodeBs in a band neighbouring the E-GSM-R band (band 8 or band 20).
- Fixed attenuators RF cable wired to the output of each eNodeB.
- 3GPP Channel Fading Simulator wired to the fixed attenuators to insert the fading.
- On-board LTE modem RF cable wired to the 3GPP Channel Fading Simulator.
- Traffic Generator/Analyser port connected to IP port of the On-board LTE modem.
- Service Gateway connected to each eNodeB via IP connection.
- Traffic Generator/Analyser port connected to IP port of Serving Gateway.

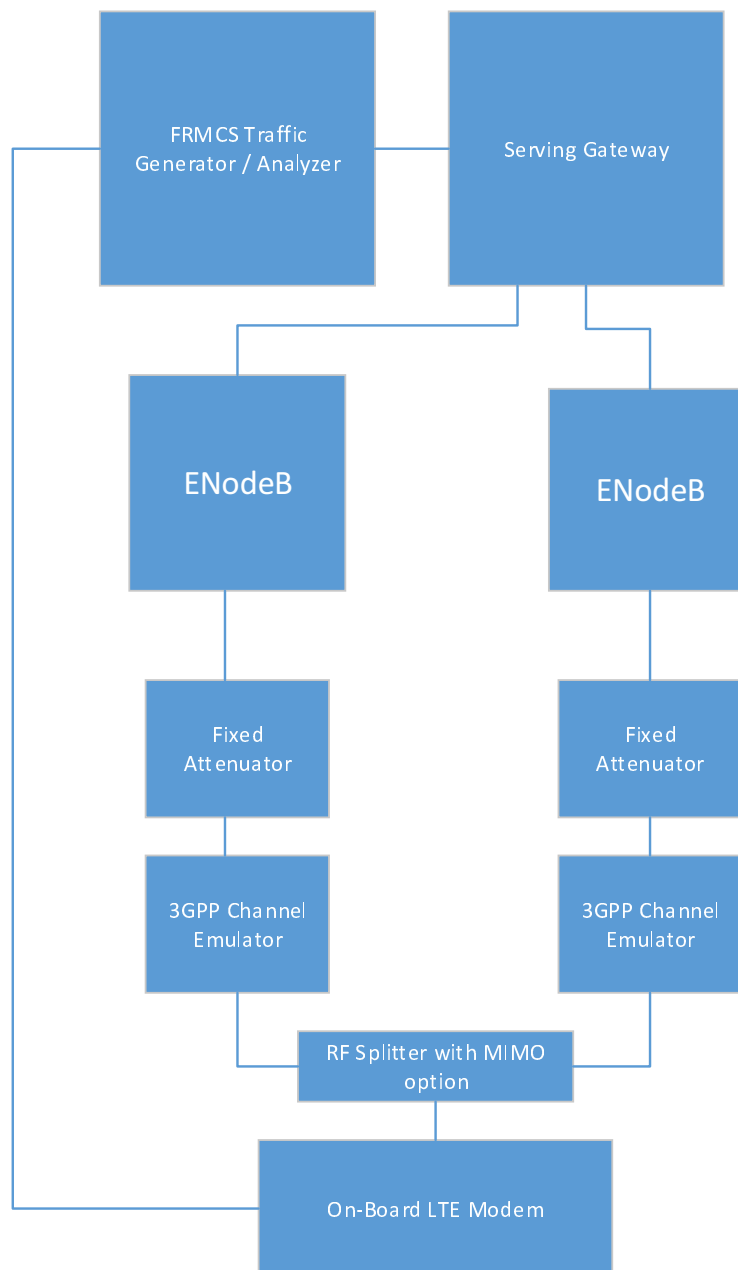

Figure 8: Architectural diagram of the Lab Simulation Setup

5.2.1.2 Lab setup: 3GPP RF Channel Emulator

Fading Profiles Available: Constant, Rayleigh, Rice, Nakagami, Lognormal, Suzuki, Pure Doppler, flat, rounded, Gaussian, Jakes, Butterworth, user-defined profiles, models from 3rd party simulation tools and ray-tracing applications.

Channel Configuration Topologies: Single or multiple independent or fully synchronized MIMO, MISO, SIMO, SISO, CoMP and relaying transmission schemes.

Run-time fading engine Amplitude, delay, Doppler and environment separately controlled for each fading channel.

Emulation of 2D and 3D beamforming channels, single and multi-user scenarios.

Emulation of high speed train scenarios, measured with channel sounder or defined with channel modelling tools.

Geometric channel modelling tool for user-defined Multi-link MIMO, beamforming and smart antenna testing; includes dynamic spatial, defined antenna patterns.

5.2.1.3 Lab setup: FRMCS Traffic Generator and Analyser

Multi-FRMCS Application emulation provides end-to-end measurements from ingress/egress of SGW to the ingress/egress of the UE per application or bearer. Data emulation supports voice, video, and data traffic generation. Dedicated radio bearers are established from the test system and the service type is appropriately mapped to the correct bearer. By fully-loading the lab environment with enough traffic to cause congestion and resource contention of the RF interface it is possible to determine the maximum throughput per bearer, per UE and per channel.

By setting traffic generator to configure layer 7 (L7) activities it is possible to emulate FRMCS application activities according to specific QCI and DSCPs. The traffic analyser then measures QCI performance for each of the L7 activities.

KPIs for FRMCS applications include:

- Loss packets.
- Max and average jitter.
- Average latency.
- Mean Opinion Score (MOS).
- Throughput.

QoS Validation

It is possible using this setup to measure the performance of the network while varying input loads, such as traffic rates and types, and subscriber classes. In this way one can vary specific FRMCS activities and measure the QoS impact on the others. One of the railway's important tests is the verification of latency thresholds that ensure delay-sensitive train control and REC traffic gets priority over best-effort data traffic. The railway can use the traffic generator equipment to emulate a constant level of data traffic (number of subscribers and data rate), while increasing the level of emulated train control or REC traffic.

5.2.2 Specific assumptions and parameters

No specific parameters and assumptions have been considered. See clause 4.7.

5.2.3 Results

No results available from this set.

5.2.4 Notes and remarks

No results available from this set.

5.3 Results set 3 (900 MHz band)

5.3.1 Description

The primary objective of the study for this result set is to assess the uplink throughput performance of an LTE based radio setup when used in a Railways environment.

For that purpose, measurements have been carried out under conditions as close as possible to "real life" railways situation.

An evolved radio test bench, including a wireless channel emulator, has been customized to reflect the most critical railways and high-speed propagation conditions.

Extra features have been implemented to manually select the Modulation Coding Scheme (MCS) and measure throughput for each of them.

The test set-up is represented in Figure 9.

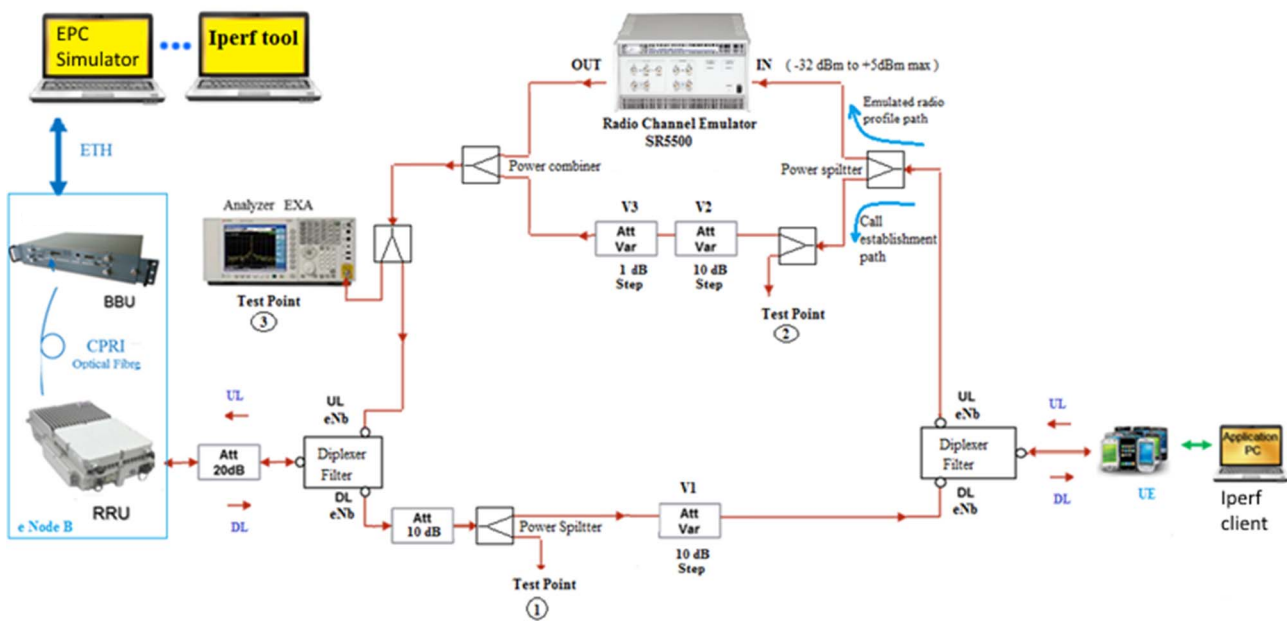

Figure 9: Measurement setup schematic

Data throughput evaluation (UDP throughput using 1 024 bytes packet size.) was assessed with widely-used Iperf network performance measurement and tuning tool (see <https://iperf.fr/>). Every throughput value provided in clause 5.3.3 is the average of at least one hundred fluctuating values over a period of time of at least 100 s. Iperf is delivering 1 throughput value per second. Reported results are about effective payload.

Multipath are simulated with a Spirent Radio Channel Emulator SR 5500. This device is able to add white Gaussian noise to generate desired SNR level.

5.3.2 Specific assumptions and parameters

5.3.2.1 Common assumptions

Parameters for these experiments have been selected as close as possible to recommendations. Exceptions or complementary information are listed below:

- Mobile handset is a category 3 USB dongle:
 - Maximum constellation is 16 QAM.
- Network loading is 1 user.
- Normal Cyclic Prefix.
- Configuration under test is 1x1, however an extrapolation is performed to evaluate 1x2 (receive diversity at eNB level).
- Down Link path is not experiencing multi-path effects.
- Multipath scenario is derived from ETSI TS 145 005 [i.1].

A simplified link budget has been made to evaluate worst case SNR (at Hand Over point: HO) and extract minimum guaranteed data throughput along the track. SNR are given for two antenna gain (17 dBi and 21 dBi) and extrapolation are given to evaluate performance with 2 way Rx diversity at Base Station level.

5.3.2.2 Hilly channel model

- Hilly terrain profile is used; however, profile is restricted to 6 taps.
- Considered Doppler shift is higher than the one resulting from the speed, it is incorporating some double effect part (Shift is doubled), applied shifts are:
 - 360 km/h: 600 Hz (named HT600).
 - 500 km/h: 834 Hz (named HT834).
- Speeds are: 360 km/h and 500 km/h for 3 MHz LTE Channel BW, and 360 km/h for LTE 1,4 MHz Ch BW.

The simplified link budget computation for the hilly channel is given in Table 39.

Table 39: Simplified link budget at HO point for Hilly channel model

| UL link budget (1x1) | | | |
|----------------------------|-------------------------|--------|--------|
| Train parameters | UE Tx power (dBm) | 23 | |
| | Coupling loss (dB) | 2 | |
| | Antenna gain (dB) | 2 | |
| | EIRP (dBm) | 23 | |
| | Height (m) | 4 | |
| Base station | Antenna gain (dB) | 17 | 21 |
| | Height (m) | 40 | |
| | Coupling loss (dB) | 3 | |
| | eNB NF (dB) | 3 | |
| Path loss (BS 40 m, MS 4m) | Distance (km) | 4 | |
| | Path loss (dB) | 129 | |
| | Standard deviation (dB) | 8 | |
| | Margin for 95% (dB) | 13,2 | |
| | Guaranteed (dB) | 142,2 | |
| | UL Rx lev (dBm) | -105,2 | -101,2 |
| LTE 1,4 MHz | Thermal noise (dBm) | -113,7 | |
| | Noise floor (dBm) | -110,7 | |
| | SNR (dB) | 5,5 | 9,5 |
| | Rx Div min gain (dB) | 3,0 | |
| | SNR with Rx Div (dB) | 8,5 | 12,5 |
| LTE 3 MHz | Thermal noise (dBm) | -110,0 | |
| | Noise floor (dBm) | -107,0 | |
| | SNR (dB) | 1,8 | 5,8 |
| | Rx Div min gain (dB) | 3,0 | |
| | SNR with Rx Div (dB) | 4,8 | 8,8 |

5.3.2.3 Rural channel model

Two channel profiles have been defined considering UL path for a train moving at 360 km/h toward the antenna mast and away from the antenna mast.

It is assumed that the UE is using the stronger direct path (LOS) to synchronize.

Since direct path is frequency shifted due to the doppler effect, then the UE emission will also experience a frequency shift by the same amount:

- 1) *Train is moving toward the antenna mast:* RA295 Hz (fading doppler) + 310 Hz of fixed frequency shift:
 - +310 Hz is the maximum doppler shift experienced in DL considering a centre frequency of 930 MHz, a train speed of 360 km/h and an angle of arrival of 0° (realistic when the train is far from the BTS site).

- 295 Hz is the fading doppler in UL considering a centre frequency of 885 MHz and a train speed of 360 km/h.
- Shortest path is defined with an angle of arrival of 0°, a Rician factor of 6,9 dB and a RICE doppler spectrum.

In details: 310 Hz frequency shift is assuming an angle of arrival of 0° of the DL direct path element (= LOS @ 930 MHz). To be coherent, in UL (885 MHz), the same angle of arrival 0° is taken that leads to a 295 Hz LOS doppler frequency shift. The other 295 Hz fading doppler, stands for the UL channel fluctuating rate, and set the classical doppler spectrum limits. The rician factor set the power ratio between the direct path (LOS) energy and scattering energy (modelled as a classical doppler spectrum):

- 2) *Train is moving away from the antenna mast:* RA295Hz (fading doppler) - 310 Hz of fixed frequency shift:
- -310 Hz is the maximum negative doppler shift experienced in DL considering a centre frequency of 930 MHz, a train speed of 360 km/h and an angle of arrival of 180° (realistic when the train is far from the BTS site).
 - 295 Hz is the fading doppler in UL considering a centre frequency of 885 MHz and a train speed of 360 km/H.
 - Shortest path is defined with an angle of arrival of 180°, a Rician factor of 6,9 dB and a RICE doppler spectrum.

It is important to note that the two profiles are giving equivalent results.

The simplified link budget computation for the Rural channel is given in Table 40.

Table 40: Simplified link budget at HO point for Rural channel model for 1,4 MHz and 3 MHz

| UL budget link (1x1) - Std Dev = 6 dB + Diversity sensitivity gain extrapolation BS antenna height = 40 m | | | | | | | |
|---|---------------------------|--------|------|--------|------|--------|------|
| Train parameters | UE Tx power (dBm) | 23 | | 26 | | 31 | |
| | Coupling loss (dB) | 2 | | 2 | | 2 | |
| | Antenna gain (dB) | 2 | | 2 | | 2 | |
| | EIRP (dBm) | 23 | | 26 | | 31 | |
| | Height (m) | 4 | | 4 | | 4 | |
| Base station | Antenna gain (dBi) | 17 | 21 | 17 | 21 | 17 | 21 |
| | Height (m) | 40 | | 40 | | 40 | |
| | Coupling loss (dB) | 3 | | 3 | | 3 | |
| | eNB NF (dB) | 3 | | 3 | | 3 | |
| Path loss | Distance (km) | 4 | | 4 | | 4 | |
| | Rural area path loss (dB) | 129 | | 129 | | 129 | |
| | Standard deviation (dB) | 6 | | 6 | | 6 | |
| | Margin for 95% (dB) | 10 | | 10 | | 10 | |
| | Guaranteed (dB) | 139 | | 139 | | 139 | |
| | UL Rx lev (dBm) | -102 | -98 | -99 | -95 | -94 | -90 |
| LTE 1,4 MHz | Thermal noise (dBm) | -113,7 | | -113,7 | | -113,7 | |
| | Noise floor (dBm) | -110,7 | | -110,7 | | -110,7 | |
| | SNR (dB) | 8,7 | 12,7 | 11,7 | 15,7 | 16,7 | 20,7 |
| | SNR with Rx Div gain (dB) | 11,7 | 15,7 | 14,7 | 18,7 | 19,7 | 23,7 |
| LTE 3 MHz | Thermal noise (dBm) | -110,0 | | -110,0 | | -110,0 | |
| | Noise floor (dBm) | -107,0 | | -107,0 | | -107,0 | |
| | SNR (dB) | 5,0 | 9,0 | 8,0 | 12,0 | 13,0 | 17,0 |
| | SNR with Rx Div gain (dB) | 8,0 | 12,0 | 11,0 | 15,0 | 16,0 | 20,0 |

NOTE: For 30 m antenna height, SNR values are by 2 dB below the values computed for 40 m antenna height.

Similarly, a rural channel profile for 500 km/h has been designed by extrapolation, with fading Doppler at 410 Hz and an additional fixed frequency shift of 431 Hz.

5.3.3 Results

5.3.3.1 Hilly channel model

In this clause, only LTE 1,4 MHz channel BW with 360 km/h is considered, other results are available in annex C. Results are reported and SNR conditions at HO point are superimposed to derive corresponding data rate.

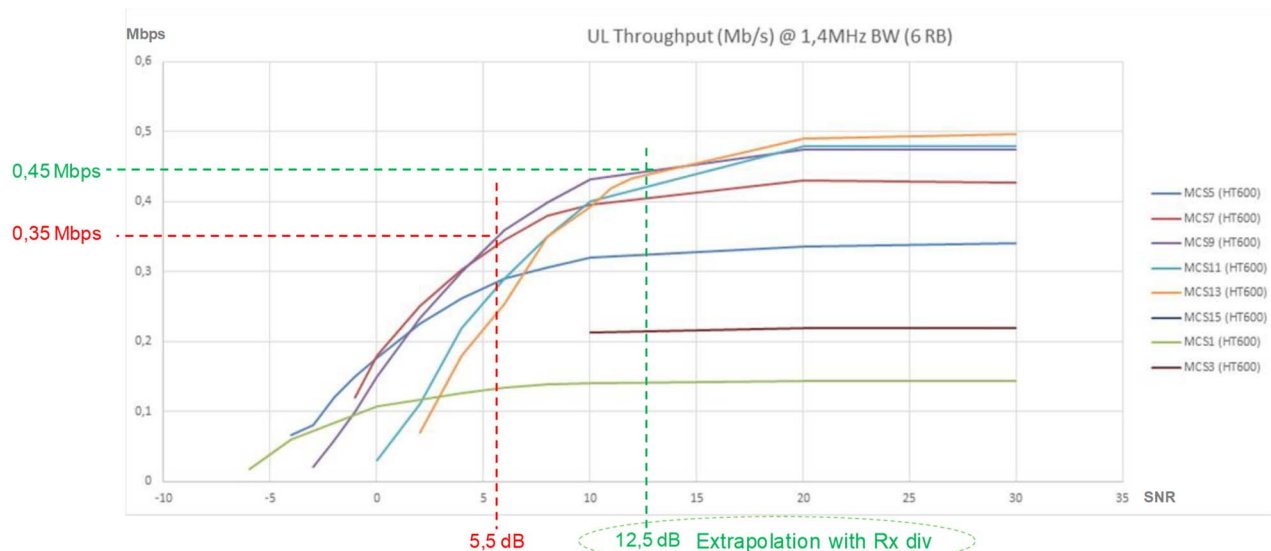

Figure 10: Measurement results for 1,4 MHz channel BW at 360 km/h and Hilly channel model

The measurements are made on a per MCS (Modulation Coding Scheme) basis. On real conditions, an adaptive feature (AMC: Adaptive Modulation and Coding) will be used to get access to the envelope of all results.

The minimum data throughput is obtained with 17 dBi antenna and without Rx diversity. This corresponds to 5,5 dB SNR and offers 0,35 Mbit/s data throughput.

Using 21 dBi antenna and with Rx diversity 3 dB minimum gain, SNR reaches 12,5 dB which corresponds to 0,45 Mbit/s.

Similar curves for 3 MHz with 360 km/h and 500 km/h are given in annex C.

Results are summarized in Table 41.

Table 41: Guaranteed data throughput at HO point for Hilly channel model

| Data throughput (Mbps) | | 17 dBi ant gain | | 21 dBi ant gain | |
|------------------------|--------------|-----------------|------|-----------------|------|
| | | Rx diversity | | Rx diversity | |
| LTE Ch BW | Speed (km/h) | Without | With | Without | With |
| 3 | 360 | 0,61 | 0,81 | 0,9 | 1,05 |
| 3 | 500 | 0,42 | 0,55 | 0,6 | 0,68 |
| 1,4 | 360 | 0,35 | 0,43 | 0,4 | 0,45 |

It is believed that actual results in the field would be better and this is explained in clause 5.3.4.

5.3.3.2 Rural channel model

This clause provides results with a rural channel model and 3 MHz bandwidth, for train speeds up to 500 km/h. Results are reported and SNR conditions at HO point are superimposed to derive corresponding data rate.

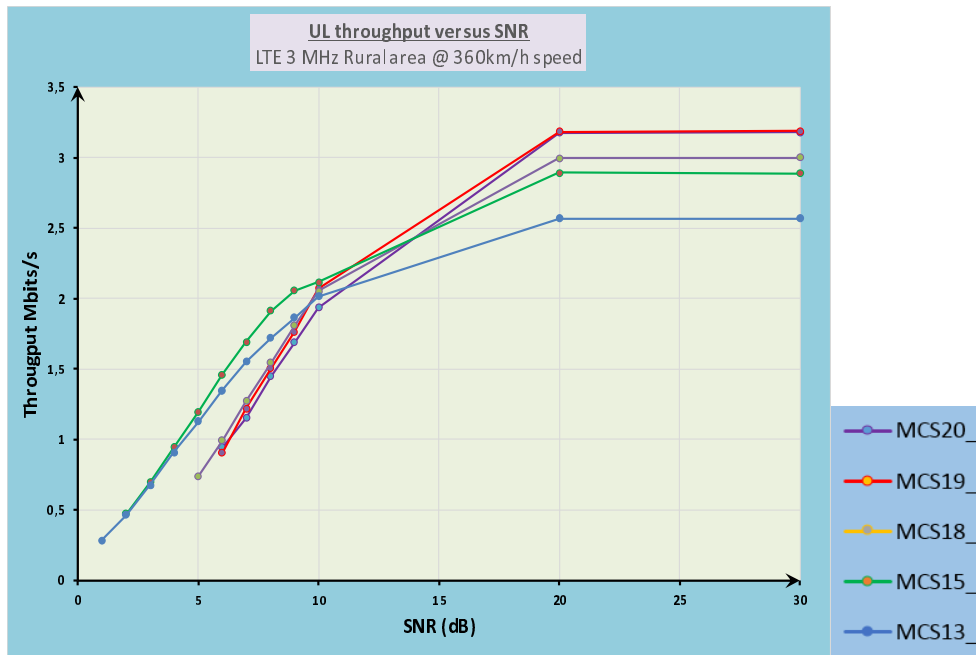

Figure 11: Measurement results for 3 MHz channel BW at 360 km/h and Rural channel model

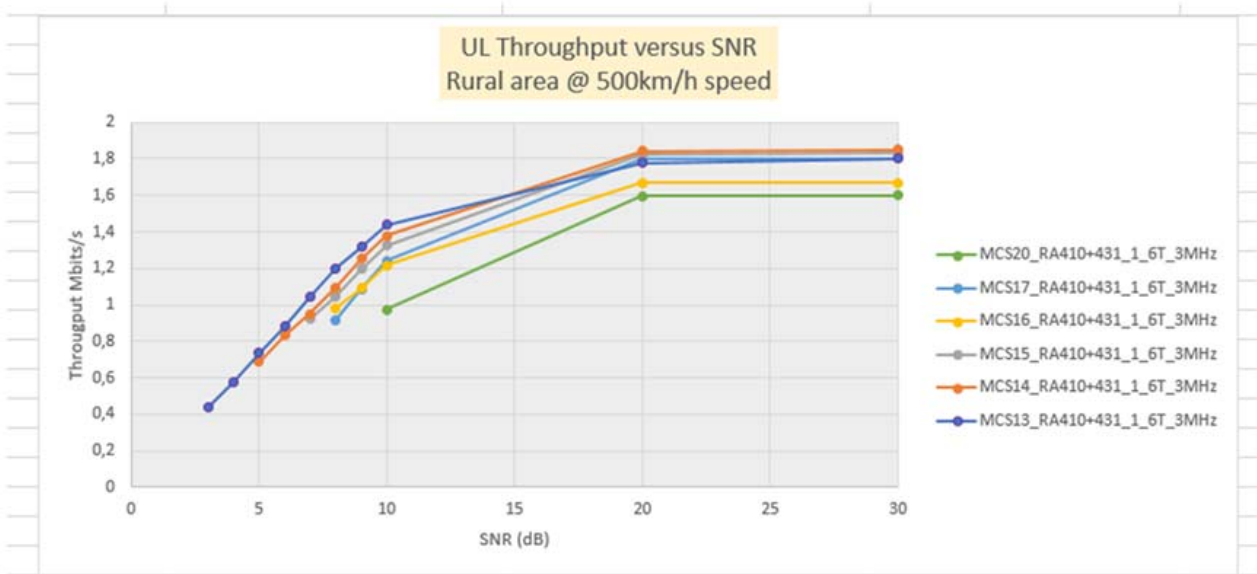

Figure 12: Measurement results for 3 MHz channel BW at 500 km/h and Rural channel model

Table 42: Guaranteed data throughput at HO point for Rural channel model

| UL LTE 3 MHz Throughput with Rx diversity sensitivity gain (2 antennas) | | | | | | | |
|---|---------------------------|--|------|------|------|------|------|
| UE Tx power (dBm) | | 23 | | 26 | | 31 | |
| Antenna gain (dBi) | | 17 | 21 | 17 | 21 | 17 | 21 |
| Height 40 m | SNR with Rx Div gain (dB) | 8,0 | 12,0 | 11,0 | 15,0 | 16,0 | 20,0 |
| | Throughput (Mbps) | 1,9 | 2,2 | 2,1 | 2,6 | 2,7 | 3,2 |
| Height 30 m | SNR with Rx Div gain (dB) | 6,0 | 10,0 | 9,0 | 13,0 | 14,0 | 18,0 |
| | Throughput (Mbps) | 1,45 | 2,1 | 2,2 | 2,4 | 2,5 | 2,9 |
| Note | | LTE 3 MHz throughputs for 10 dB < SNR < 20 dB are interpolated | | | | | |

In case of rural environment and considering a 3 MHz LTE carrier, a minimum guaranteed UL throughput of 1,45 Mbits/s can be expected, to be shared by all UEs in the cell. A maximum UL throughput of 3,2 Mbits/s at the speed of 360 km/h.

For a 5 MHz bandwidth channel, data has been extrapolated with the following methodology:

- BW difference impact on SNR:
 - UE Tx power is constant, thus SNR in 5 MHz channel is to be corrected for RF occupied bandwidth.
 - 3 MHz → 15 RB, 5 MHz → 25 RB.
 - SNR is lower by: $10 \times \log_{10}(25/15) = 2,22$ dB.
- BW impact on capacity:
 - Data throughput multiplied by: $25/15 = 1,66$.

This leads to the following link budget and data throughput for 5 MHz of bandwidth.

Table 43: Link budget and data throughput at HO point for Rural channel model for 5 MHz

| UL LTE 5 MHz Throughput with Rx diversity sensitivity gain (2 antennas) extrapolated from LTE 3 MHz UL with Rx diversity sensitivity gain | | | | | | |
|---|-----|------|------|------|------|------|
| UE Tx power (dBm) | 23 | | 26 | | 31 | |
| Antenna gain (dBi) | 17 | 21 | 17 | 21 | 17 | 21 |
| SNR with Rx Div gain (dB) | 8,0 | 12,0 | 11,0 | 15,0 | 16,0 | 20,0 |
| LTE 3 MHz Throughput (Mbps) | 1,9 | 2,2 | 2,1 | 2,6 | 2,7 | 3,2 |
| LTE 5 MHz Corrected SNR (dB) | 5,8 | 9,8 | 8,8 | 12,8 | 13,8 | 17,8 |
| Corrected Throughput in 3 MHz (Mbps) | 1,4 | 2,1 | 2 | 3,15 | 2,5 | 3 |
| LTE 5 MHz Throughput (Mbps) | 2,3 | 3,5 | 3,3 | 5,3 | 4,2 | 5,0 |

LTE 3 MHz throughputs for $10 \text{ dB} < \text{SNR} < 20 \text{ dB}$ are interpolated.

5.3.4 Notes and remarks

The actual performance in the field could be better than the results of these experiments:

- Hilly Terrain is simulated with 6 taps. However, during experiments it has been noticed that a richer environment has a positive impact on data throughput. ETSI TS 145 005 [i.1] offers the possibility of Hilly Terrain with 12 taps. Using this set-up gave higher data throughput.
- Rx diversity. Actual diversity in the field offers 3 dB gain at minimum gain. However, practical gain is higher since Rx diversity offers better processing possibilities for the signal.
- Extended CP could also be a key contributor to enhance data throughput. Latest echo for Hilly Terrain from ETSI TS 145 005 [i.1] Hilly Terrain profile is $20 \mu\text{s}$ later than main signal. Normal CP used in this experiment offers protection against ISI up to $4,6 \mu\text{s}$, and extended CP offers protection up to $16 \mu\text{s}$. It is expected that this could be beneficial for data throughput.
- Actual Doppler shift range could be lower in real life.
- MCS delivering best data throughput depends on propagation scenario. This is illustrated with the graph: "Maximum data rate per MCS vs. conditions (3 MHz)"(Figure C.4).

6 Results evaluation

6.1 Analysis at 900 MHz

6.1.1 General

Table 44 summarizes the assumption differences between the evaluation sets §1 and §3 that seem to have the highest impact on throughput results.

Table 44: Assumption differences between the evaluation sets

| Result Set §1 | Results Set §3 | Remarks |
|---|--|---|
| Link simulation: channel and TX/Rx are simulated | Actual transmission devices, channel emulation | |
| System simulation including deployment impact, in particular including interference from neighbouring cells | One cell only. Interferences from neighbours not included in link budget | Interference is a strong limiting factor |
| Frequency-domain channel estimation: Wiener | Not Available | |
| Time-domain channel estimation: Time interpolation between pilots among and between sub-frames at receiver | Probably no interpolation | |
| Doppler model follows the spatial channel model (AoD/AoA) | Random Doppler shift ([i.1]) | |
| Commercial antenna diagram (KATHREIN) | Fixed antenna gain | The antenna diagram may have an impact on Doppler action |
| Gross throughput: Overhead of pilot signals and cyclic prefix included | Net payload throughput: All the protocol stack overhead is included | An estimation of protocol stack overhead is necessary to conclude |
| No HARQ | HARQ included (up to 4 retransmissions) | HARQ brings a gain in terms of PER, with a cost on delay and transmission resources |
| Extended CP | Normal CP | |

The two sets are not operating at the same level: Result Set §1 operates at *Software simulation reference point* while Result Set §3 operates at *Hardware simulation and laboratory test reference point*, see clause 4.2).

In the following, the term *gross throughput* is used to refer to throughput corresponding to *Software simulation reference point* and *net throughput* the values obtained at *Hardware simulation and laboratory test reference point*.

6.1.2 Overhead analysis

6.1.2.1 General

To better compare the Result Sets, it is necessary to understand and assess the difference lying below the *gross throughput* and the *net throughput* evaluations.

This clause assumes a static UE (i.e. train).

6.1.2.2 IP stack, PDCP and RLC overhead

IP stack overhead corresponds to the overhead of the IP/UDP used by the application Iperf in result set §3.

The PDCP may compress the IP header. Compression depends on the type of packet (IP/UDP, IP TCP, etc.), and compressor is a state machine, i.e. the compression ratio depends of the time and of the transport conditions. Considering one UE and a constant session, which is the scenario in the simulation/evaluation picture, PDCP could be expected to remove 20 bytes of IP header, and 8 bytes of the UDP header and replace them by 2 bytes.

MAC will add something like 4 bytes of overhead.

Then, even without header compression, considering maximum packet length of 1 500 octets, the overhead corresponds to something like 2 %, which is negligible (2,5 % with 1 024 octets packet length).

6.1.2.3 Physical layer overhead

Result Set §1 takes into account cyclic prefix and pilots overhead. But the PHY layer introduces additional overhead, related to control signalling such as PDCCH, and PBCH channels.

This overhead is different on UL and DL and depends on channel bandwidth, being more important with a small number of PRBs. This overhead is typically between 15 % and 30 %.

6.1.2.4 Link-level comparison

In order to get an upper absolute limit value, the computation of the maximum theoretical throughput is provided below, assuming no HARQ, but with pilots overhead and normal CP. The formula is provided for MCS20 (Modulation and Coding scheme) at 1,4 MHz, which corresponds to the highest MCS used in Result Set §3:

$12 \text{ sub-Carriers} \times 6 \text{ RBs} \times 12 \text{ Symbols} \times 4 \text{ bits (16 QAM)} \times 0,74 \text{ FEC Rate} / 10^{-3} \text{ (sub-frame duration)} = 2,56 \text{ Mbit/s}$

To be able to compare more easily the different results, a set of (throughput vs. SNR) curves at link level step coming from simulation chain of Result Set §1 is shown in Figure 14, to be compared with curves coming from Result set §3 (Figure 13).

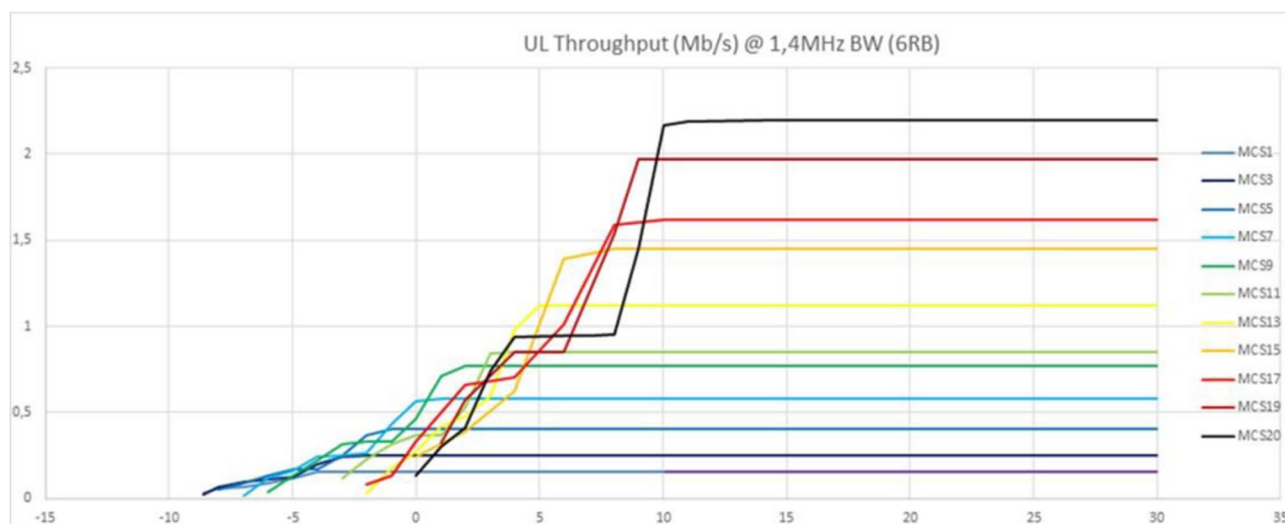

Figure 13: Net UL throughput for a static UE in case of Result Set §3 (1,4 MHz bandwidth)

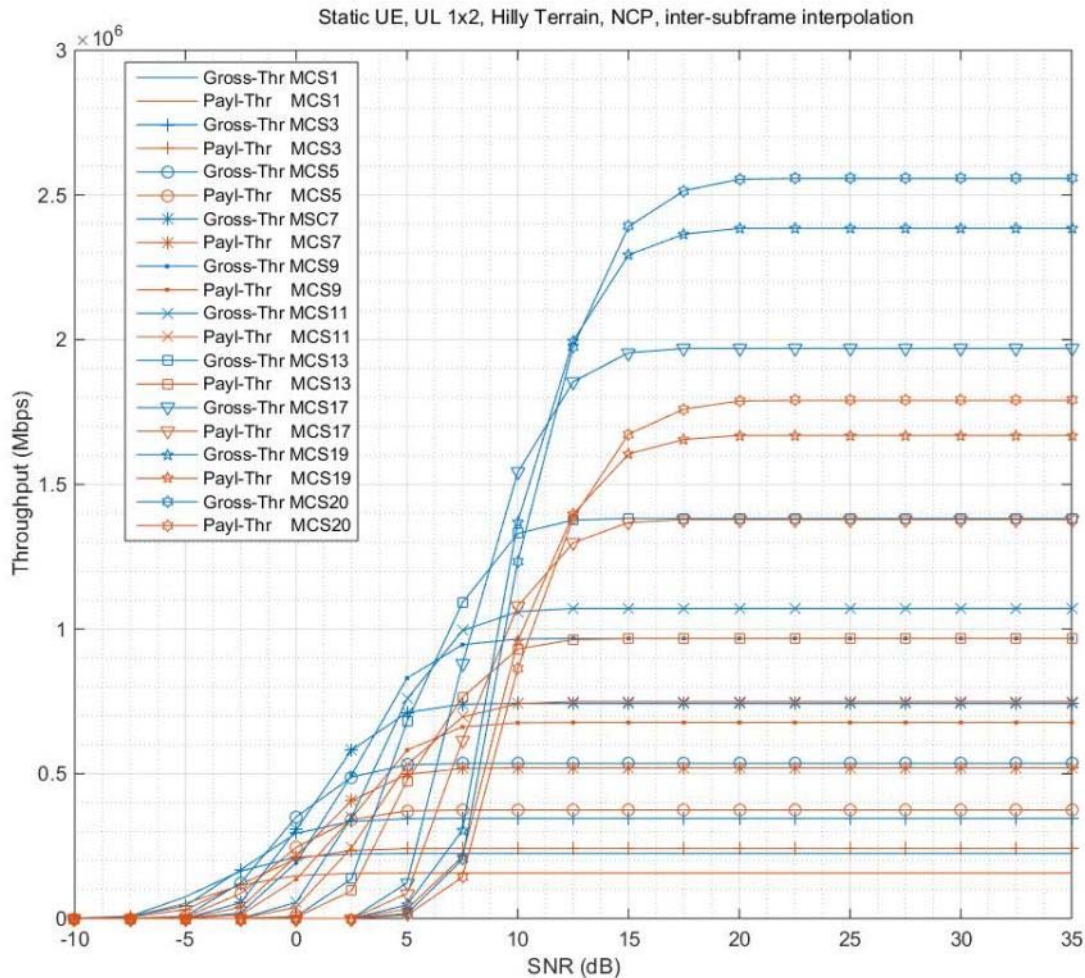

Figure 14: UL throughput for a static UE in case of Result Set §1 (link simulation) (1,4 MHz bandwidth)

For MCS 20, Result Set §3 gives a maximum throughput of 2,2 Mbit/s of net throughput. Result Set §1 gives 2,55 Mbit/s of gross throughput.

The difference between the 2 values is about 14 %, although the overhead for UL considering a 1,4 MHz bandwidth is likely to be more around 30 %. Moreover, the two sets of curves are shifted in SNR of about 10 dB: For this MCS 20, the maximum throughput is reached for a SNR of 10 dB in Result Set §3, and for a SNR around 20 dB for Result Set §1.

Hence, overhead cannot explain alone this difference. There may be other factors impacting the results:

- i) Result Set §1 assumes 2 antennas in reception, although only 1 is considered for Result Set §1. This could explain a +3 dB difference in favour of Set §1.
- ii) A second factor is the HARQ which may provide between 7 to 10 dB gain [i.6] to Result Set §3.

Hence, gross throughput in UL needs to be corrected by around 30 %, due to different overhead, but a gain of 7 to 10 dB could be expected with HARQ.

6.1.3 Train speed impact

This clause analyses the difference in Results Set §1 and Result Set §2 considering high train velocity. Figure 15 shows UL throughput for a UE at 350 km/h as provided by Result Set §3, while the UL throughput for a UE at 350 km/h at link simulation set up is provided in Figure 16.

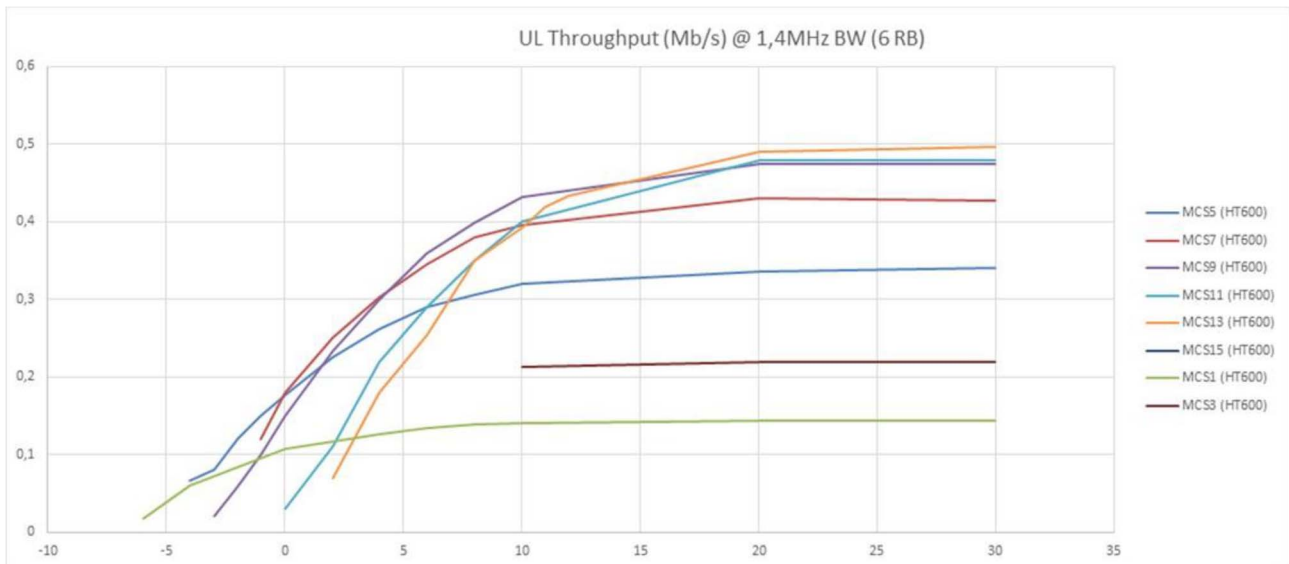

Figure 15: Net UL throughput for a UE at 350 km/h for Result Set §3 (1,4 MHz bandwidth)

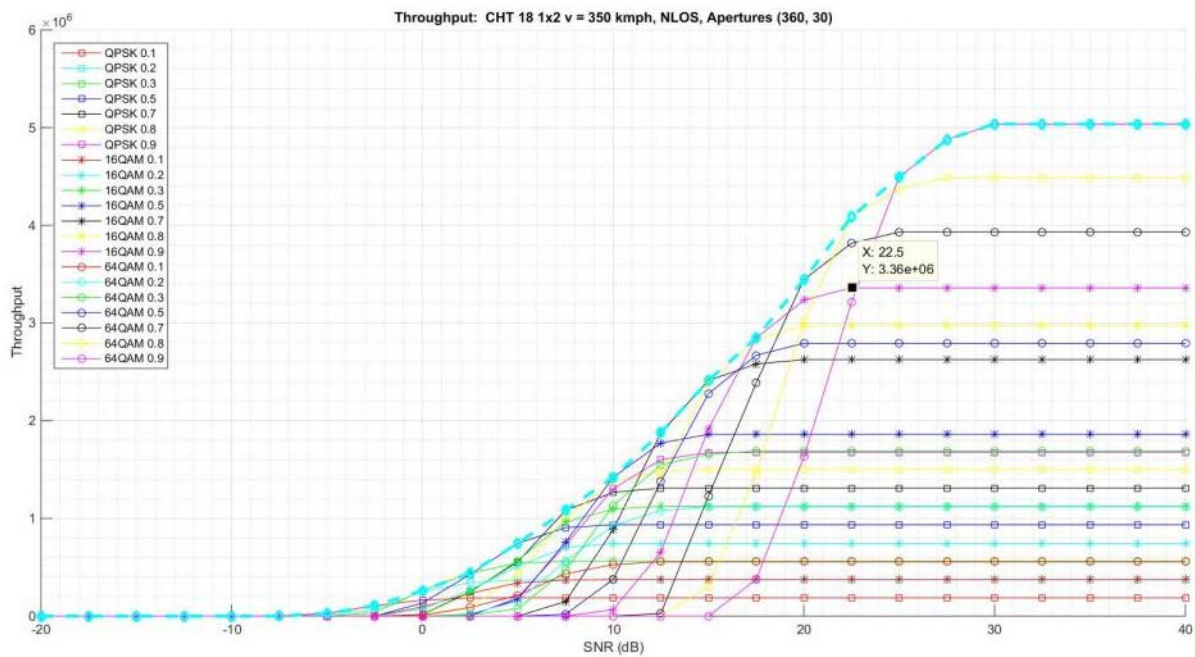

Figure 16: UL throughput for a UE at 350 km/h for Result Set §1 (link simulation only) (1,4 MHz bandwidth)

MCS 13 in Result Set §3, corresponding to 16QAM code rate 0,4, provides a max net throughput of 0,5 Mbit/s. A similar MCS in Result Set §1 indicates a gross throughput around 1,8 Mbit/s.

The difference may come from the following factors:

- Diversity gain due to the 2 Rx antenna assumed in Result Sets §1, while only 1 is present in Result Set §3.
- Antenna diagram that filters the Doppler on paths arriving at high angles in Result Set §1.
- Channel estimation time interpolation in Result Set §1.

The impact of different factors has been evaluated with a link-level simulation for one MCS corresponding to MCS 20 (16 QAM code rate 0,7) of Result Set §3, as depicted in Figure 17. Blue curves provide the gross throughput, while a 30 % overhead is assumed in the red curves. Curves labelled "AoA/D 2pi" (Angle of Arrival/Departure) corresponds to a Doppler which is spread among 360 degrees, and curves labelled "CDL" corresponds to Doppler effect following a Cluster Delay Line model.

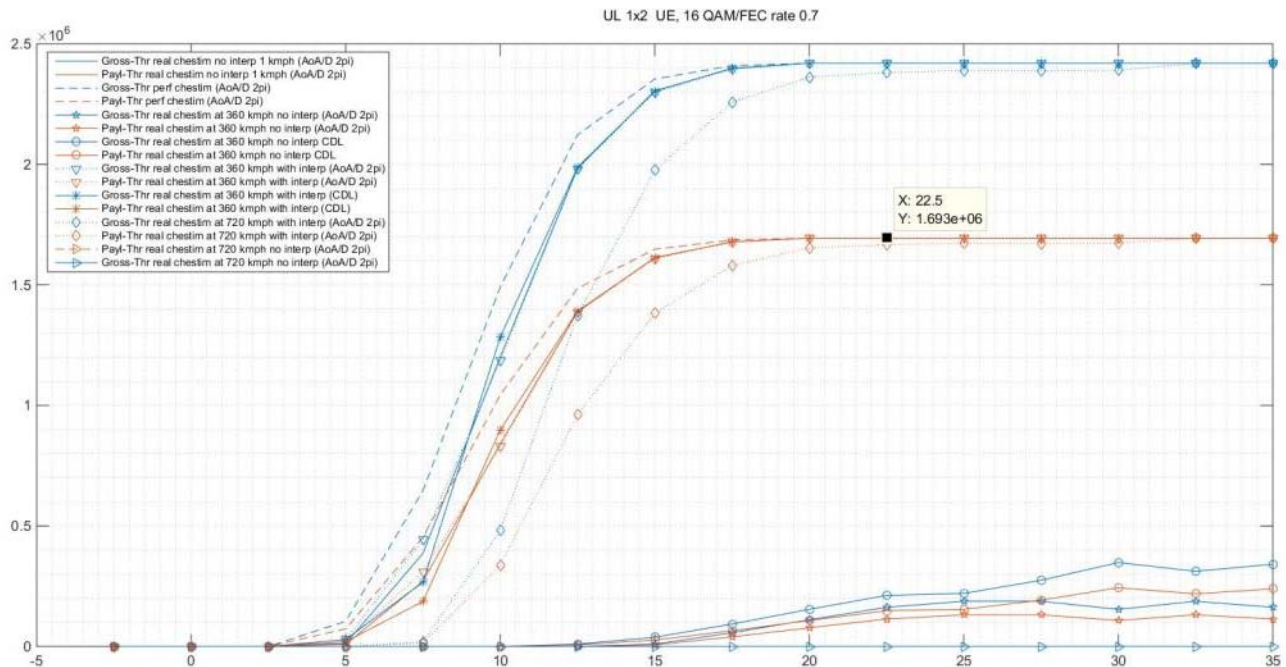

Figure 17: Impact of Doppler model and channel estimation time interpolation on throughput

The following can be observed:

- Channel estimation time interpolation has the main impact to fight against the Doppler.
- The effect of antenna filtering is noticeable, but of second order compared to channel estimation interpolation. With channel interpolation, the impact is clear in the intermediate SNR values (between 5 and 15 dB). With no interpolation and antenna diagram filtering, the maximum gross throughput is around 0,4 Mbit/s, to be compared to 0,2 Mbit/s with a random Doppler shift assumed.

The two last results are in the same order than Result Set §3, which shows 0,45 Mbit/s net max throughput, with an MCS 16 QAM code rate 0,4 (MCS 13) (which is more robust than MCS 20), and HARQ function on.

6.1.4 Neighbouring cells interference impact

Result Set §1 takes into account interference from neighbouring cells, and results shows that it is an important factor of the system performance that depends on neighbouring cell loads. Interference coordination can be performed, for example with fractional frequency reuse techniques that could be implemented in an LTE system.

6.1.5 HARQ impact estimation

Along with the second round of simulation of Result Set §1, the impact of HARQ has been estimated at the hand-over point by artificially pushing up the SINR by a fixed value of 6 dB. The actual effect of a true HARQ algorithm is more complex than just raising the SINR, but this approach provides an overview of what could be expected when HARQ is taken into account. Table 45 provides the result for UL in high speed scenario for metrics *Smth. 100 m median cell edge* and *Smth. 100 m worst cell edge*. The impact is not big enough for the frequency reuse 1 scheme to provide a meaningful guaranteed throughput at cell edge - the interference level is too high; however, the improvement is significant as soon as some interference mitigation is in place.

Table 45: Set §1 - Second Round - HARQ impact estimation

a) 1,4 MHz - High speed scenario - HARQ estimation

| Bandwidth (MHz) | Speed (km/h) | Tx Power (dBm) | Reuse factor | UL | Throughput (Mbit/s) | | | | |
|-----------------|--------------|----------------|--------------|-----|---------------------|------------------------------|-----------------------------|------------------------------|-----------------------------|
| | | | | | No HARQ | | | HARQ impact estimation | |
| | | | | | Cell centre | Smth. 100 m median cell edge | Smth. 100 m worst cell edge | Smth. 100 m median cell edge | Smth. 100 m worst cell edge |
| 1,4 | 350 | 26 | 1 | 1x2 | 3,81 | 0,20 | 0,00 | 0,68 | 0,02 |
| | | | 1 | 1x4 | 3,85 | 0,38 | 0,00 | 1,16 | 0,05 |
| | | | 2 | 1x2 | 1,90 | 1,48 | 0,81 | 1,86 | 1,24 |
| | | | 2 | 1x4 | 1,92 | 1,84 | 1,15 | 1,92 | 1,66 |
| | | | 3 | 1x2 | 1,27 | 1,17 | 0,81 | 1,27 | 1,12 |
| | | | 3 | 1x4 | 1,28 | 1,28 | 1,10 | 1,28 | 1,28 |

b) 3 MHz - High speed scenario - HARQ estimation

| Bandwidth (MHz) | Speed (km/h) | Tx Power (dBm) | Reuse factor | UL | Throughput (Mbit/s) | | | | |
|-----------------|--------------|----------------|--------------|-----|---------------------|------------------------------|-----------------------------|------------------------------|-----------------------------|
| | | | | | No HARQ | | | HARQ impact estimation | |
| | | | | | Cell centre | Smth. 100 m median cell edge | Smth. 100 m worst cell edge | Smth. 100 m median cell edge | Smth. 100 m worst cell edge |
| 3,0 | 350 | 26 | 1 | 1x2 | 9,55 | 0,47 | 0,00 | 1,74 | 0,05 |
| | | | 1 | 1x4 | 9,61 | 0,94 | 0,00 | 2,94 | 0,14 |
| | | | 2 | 1x2 | 4,77 | 3,37 | 1,93 | 4,42 | 2,92 |
| | | | 2 | 1x4 | 4,81 | 4,28 | 2,74 | 4,81 | 4,01 |
| | | | 3 | 1x2 | 3,18 | 2,67 | 1,82 | 3,18 | 2,59 |
| | | | 3 | 1x4 | 3,20 | 3,20 | 2,48 | 3,20 | 3,17 |

c) 5 MHz - High speed scenario - HARQ estimation

| Bandwidth (MHz) | Speed (km/h) | Tx Power (dBm) | Reuse factor | UL | Throughput (Mbit/s) | | | | |
|-----------------|--------------|----------------|--------------|-----|---------------------|------------------------------|-----------------------------|------------------------------|-----------------------------|
| | | | | | No HARQ | | | HARQ impact estimation | |
| | | | | | Cell centre | Smth. 100 m median cell edge | Smth. 100 m worst cell edge | Smth. 100 m median cell edge | Smth. 100 m worst cell edge |
| 5,0 | 350 | 26 | 1 | 1x2 | 15,89 | 0,77 | 0,00 | 3,01 | 0,07 |
| | | | 1 | 1x4 | 16,03 | 1,51 | 0,00 | 4,86 | 0,23 |
| | | | 2 | 1x2 | 7,95 | 5,08 | 2,83 | 6,91 | 4,63 |
| | | | 2 | 1x4 | 8,02 | 6,87 | 4,39 | 8,02 | 6,25 |
| | | | 3 | 1x2 | 5,30 | 4,09 | 2,75 | 5,14 | 3,95 |
| | | | 3 | 1x4 | 5,34 | 5,15 | 3,77 | 5,34 | 4,97 |

d) 3 MHz - Hilly scenario - HARQ estimation

| Bandwidth (MHz) | Speed (km/h) | Tx Power (dBm) | Reuse factor | UL | Throughput (Mbit/s) | | | | |
|-----------------|--------------|----------------|--------------|-----|---------------------|------------------------------|-----------------------------|------------------------------|-----------------------------|
| | | | | | No HARQ | | | HARQ impact estimation | |
| | | | | | Cell centre | Smth. 100 m median cell edge | Smth. 100 m worst cell edge | Smth. 100 m median cell edge | Smth. 100 m worst cell edge |
| 3,0 | 160 | 26 | 1 | 1x2 | 9,66 | 0,00 | 0,00 | 0,00 | 0,00 |
| | | | 1 | 1x4 | 9,71 | 0,00 | 0,00 | 0,02 | 0,00 |
| | | | 2 | 1x2 | 4,83 | 0,90 | 0,01 | 1,74 | 0,29 |
| | | | 2 | 1x4 | 4,86 | 1,56 | 0,10 | 2,80 | 0,61 |
| | | | 3 | 1x2 | 3,22 | 1,02 | 0,17 | 1,77 | 0,57 |
| | | | 3 | 1x4 | 3,24 | 1,67 | 0,37 | 2,54 | 0,99 |

e) 1,4 MHz - Hilly scenario - HARQ estimation

| Bandwidth (MHz) | Speed (km/h) | Tx Power (dBm) | Reuse factor | UL | Throughput (Mbit/s) | | | | |
|-----------------|--------------|----------------|--------------|-----|---------------------|------------------------------|-----------------------------|------------------------------|-----------------------------|
| | | | | | No HARQ | | | HARQ impact estimation | |
| | | | | | Cell centre | Smth. 100 m median cell edge | Smth. 100 m worst cell edge | Smth. 100 m median cell edge | Smth. 100 m worst cell edge |
| 1,4 | 160 | 26 | 1 | 1x2 | 3,87 | 0,00 | 0,00 | 0,01 | 0,00 |
| | | | 1 | 1x4 | 3,87 | 0,00 | 0,00 | 0,02 | 0,00 |
| | | | 2 | 1x2 | 1,93 | 0,40 | 0,02 | 0,77 | 0,12 |
| | | | 2 | 1x4 | 1,93 | 0,66 | 0,05 | 1,19 | 0,26 |
| | | | 3 | 1x2 | 1,29 | 0,44 | 0,09 | 0,78 | 0,25 |
| | | | 3 | 1x4 | 1,29 | 0,73 | 0,19 | 1,13 | 0,43 |

6.1.6 Results comparison and *net throughputs* at hand-over point

This clause compares some Results set §1 and Results set §3 throughputs, taken into account different correction factors discussed in previous clauses, so as to better align the different assumptions.

For Result set §1, a *gross throughput* value is picked up as *Smth. 100 m worst cell edge* metric with no HARQ providing the best result for a given scenario. This is considered as the low range value. The high range is computed from *Smth. 100 m worst cell edge* with HARQ impact estimation. Then, *gross throughput values* are converted into *net throughput* values by taking into account an overhead of 30 % for 1,4 MHz bandwidth and 15 % for 3 and 5 MHz bandwidths.

Result set §3 provides *net throughput* values directly. Value ranges come from different antenna gains assumptions and different UL Tx powers in the link budget estimation.

Table 46 provides a summary of the estimation of the guaranteed net throughput at cell edge in uplink direction as estimated by Results sets §1 and §3.

Table 46: Comparison between Results Sets §1 and §3 of UL net guaranteed throughput at hand-over point

| Scenario | Net guaranteed throughput at HO point (MBit/s) | |
|------------------|--|---------------|
| | Result set §1 | Result set §3 |
| UL Hilly 1,4 MHz | 0,1 - 0,3 | 0,3 - 0,5 |
| UL Hilly 3 MHz | 0,3 - 0,8 | 0,6 - 1,0 |
| UL Rural 3 MHz | 2,3 - 3,3 | 1,5 - 3,2 |
| UL Rural 5 MHz | 3,7 - 5,3 | 2,3 - 5,0 |

To be reminded that:

- For Results set §3:
 - Set does not take into account interferences from neighbouring cells.
 - Set does not implement Doppler mitigation techniques.
 - Results at 5 MHz are interpolated from results at 3 MHz.
- For Results set §1:
 - Throughput is computed at PHY level. *Net throughput* is extrapolated.
 - HARQ is not included in the simulations, its impact is roughly estimated.

Guaranteed net throughputs at HO point are further estimated for all the scenarios from Result set §1 with the same method:

- **Low range** corresponds to **Smth. 100 m worst cell edge** metric with no HARQ.

- **High range** is computed from **Smth. 100 m worst cell edge** with HARQ impact estimation.
- **Net throughputs** are computed from **gross throughputs** by assuming a 30 % overhead for 1,4 MHz bandwidth and a 15 % overhead for 5 MHz bandwidth.

Results are provided in Table 47.

Table 47: Net guaranteed throughput at hand-over point for the different scenarios (from Result Set §1)

| Bandwidth (MHz) | Scenario | Direction | Gross guaranteed throughput at HO point (Mbit/s) - | | Net guaranteed throughput at HO point (Mbit/s) | |
|------------------|------------------------|-----------|--|------------|--|------------|
| | | | Low range | High range | Low range | High range |
| 1,4 | High speed (350 km/h) | UL | 1,2 | 1,7 | 0,8 | 1,2 |
| | | DL | 1,2 | 1,5 | 0,8 | 1,1 |
| | Urban (80 km/h) | UL | 0,9 | 1,3 | 0,6 | 0,9 |
| | | DL | 0,5 | 0,8 | 0,4 | 0,6 |
| | High density (80 km/h) | UL | 0,2 | 0,5 | 0,1 | 0,4 |
| | | DL | 0,1 | 0,4 | 0,1 | 0,3 |
| Hilly (160 km/h) | UL | 0,2 | 0,4 | 0,1 | 0,3 | |
| | DL | 0,2 | 0,4 | 0,1 | 0,3 | |
| 5,0 | High speed (350 km/h) | UL | 4,4 | 6,2 | 3,7 | 5,3 |
| | | DL | 4,9 | 7,0 | 4,2 | 6,0 |
| | Urban (80 km/h) | UL | 3,6 | 5,1 | 3,1 | 4,3 |
| | | DL | 2,0 | 3,4 | 1,7 | 2,9 |
| | High density (80 km/h) | UL | 0,6 | 1,8 | 0,5 | 1,5 |
| | | DL | 0,5 | 1,5 | 0,4 | 1,3 |
| Hilly (160 km/h) | UL | 0,6 | 1,5 | 0,5 | 1,3 | |
| | DL | 0,8 | 1,7 | 0,7 | 1,4 | |

6.2 Analysis at 1 900 MHz

6.2.1 Overhead analysis

1 900 MHz results set considers normal cyclic prefix and pilot overhead. However, the PHY layer introduces additional overhead, related to control signalling such as PDCCH, and PBCH channels, etc.

This overhead is different on UL and DL. It varies with channel bandwidth, the number of allocated resource blocks, (being higher with a small number of PRBs), and with the uplink-downlink configuration. Moreover, the special subframe (S) structure giving the lowest signalling overhead has been assumed.

Table 48: Signaling overhead for TDD

| Uplink-downlink configuration | Actual UL / DL percentages | Remarks |
|-----------------------------------|----------------------------|--|
| Configuration 0: (labelled 75/25) | 61,4 % / 27 % | These percentages correspond to net UL/DL share over the total resources and account for the total overhead. |
| Configuration 1: labelled (50/50) | 41,4 % / 44,1 % | They are calculated over the 10 subframes (account for special subframes under special subframe config 1 which is 9 DwPTS symbols, 1 UpPTS symbol) |

6.2.2 Train speed impact

For TDD, channel estimation is more sensitive to speed since interpolation in time domain (between two subframes) is mostly not possible. In addition, in uplink, a double Doppler assumption is used to take into account both downlink Doppler profile (during synchronization) in addition to the uplink profile. In downlink, a simple Doppler profile is assumed. It can be seen that in downlink there is a better resistance to speed compared to uplink.

6.2.3 MIMO impact

Figure 18 provides the throughput versus SINR for different number of antennas at the receiver side for uplink, in urban and in rural environments. The gain of having more antennas at reception is clear, around 3 to 5 dB SNR gain when going from a 1x2 configuration to a 1x4 configuration. It can also be observed that 2x2 SFBC MIMO performs better in urban compared to rural environment. This is because of the higher spatial diversity in urban environment and the absence of LOS. However the difference appears not very significant, in particular at low SNR values.

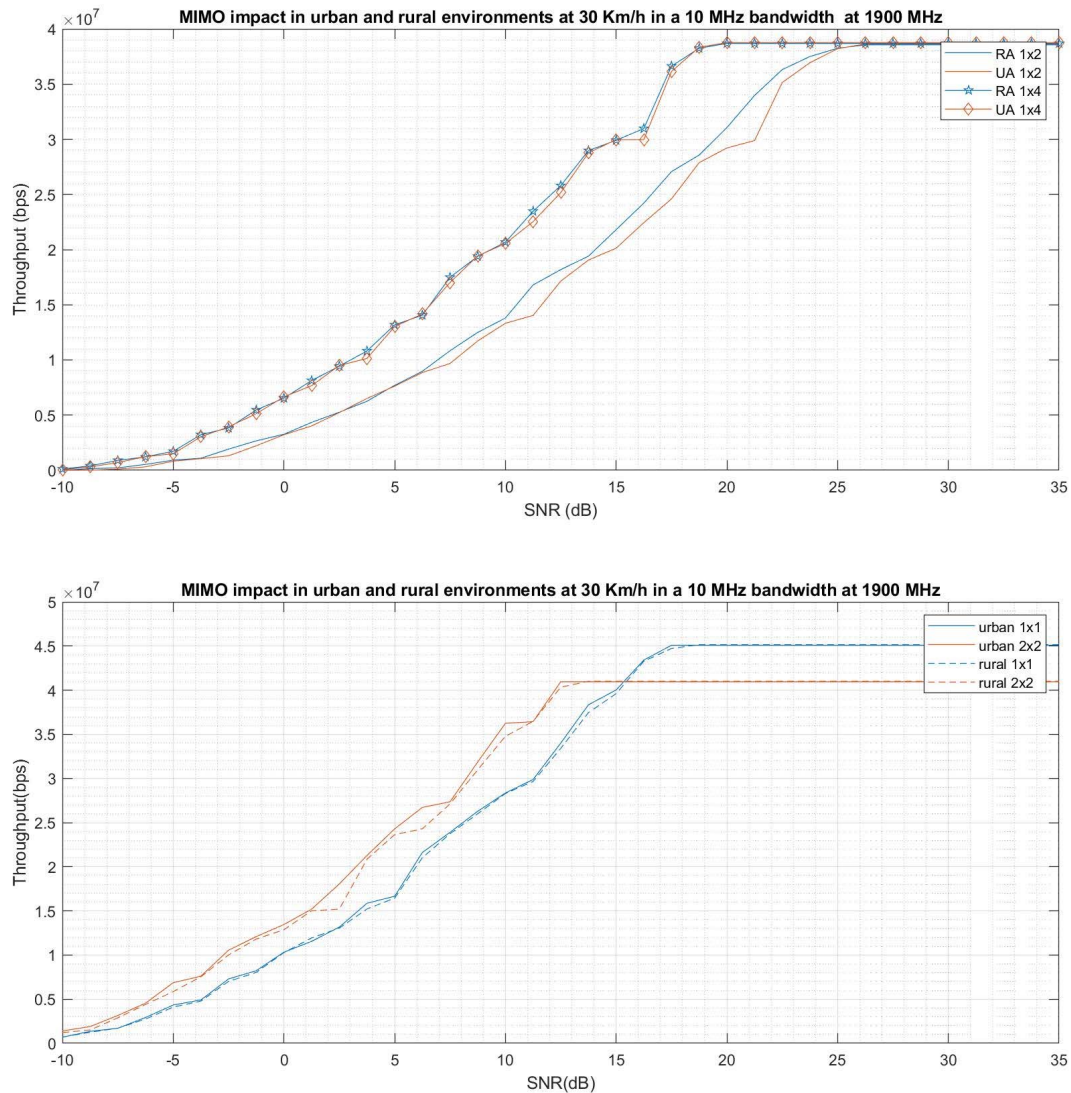

Figure 18 Impact of antenna number in rural and urban environments

6.2.4 Net throughput at cell edge

Table 49 provides a summary of guaranteed throughput results at cell edge. Gross guaranteed throughput at cell edge is taken from clause 5.1.3.3 tables by picking up the maximum achievable values for each scenario. Net guaranteed throughput at cell edge is obtained by considering the control channel overhead defined in clause 6.2.1.

NOTE 1: In this clause, net throughput at cell edge is equivalent to net throughput at handover point of the clause relative to 900 MHz (clause 6.1).

Table 49: Net guaranteed throughput at cell edge for different scenarios in 1 900 MHz band

| Scenario | Direction | Net guaranteed throughput at cell edge (Mbit/s) - 50/50 TDD | Notes |
|----------------------------------|-----------|---|--|
| High speed (350 km/h, 8 km ISD) | UL | 1,02 | Reuse factor 2, 31 dBm, MIMO 1x4 |
| | DL | 5,16 | Reuse factor 2, 63 dBm |
| High speed (350 km/h, 6 km ISD) | UL | 1,03 | Reuse factor 2, 26 or 31 dBm, MIMO 1x4 |
| | DL | 5,21 | Reuse factor 2, 63 dBm |
| High speed (350 km/h, 4 km ISD) | UL | 1,03 | Reuse factor 2, 26 or 31 dBm, MIMO 1x4 |
| | DL | 3,49 | Reuse factor 2, 63 dBm |
| Urban (80 km/h, 2 km ISD) | UL | 1,28 | Reuse factor 3, 31 dBm, MIMO 1x4 |
| | DL | 2,65 | Reuse factor 3, 63 dBm |
| High density (80 km/h, 4 km ISD) | UL | 0,45 | Reuse factor 3, 31 dBm, MIMO 1x4 |
| | DL | 2,72 | Reuse factor 3, 63 dBm |
| Hilly (160 km/h, 8 km ISD) | UL | 0,21 | Reuse factor 3, 31 dBm, MIMO 1x4 |
| | DL | 3,88 | Reuse factor 3, 63 dBm |

| Scenario | Direction | Net guaranteed throughput at cell edge (Mbit/s) - 75/25 TDD | Notes |
|----------------------------------|-----------|---|--|
| High speed (350 km/h, 8 km ISD) | UL | 1,52 | Reuse factor 2, 31 dBm, MIMO 1x4 |
| | DL | 3,16 | Reuse factor 2, 63 dBm |
| High speed (350 km/h, 6 km ISD) | UL | 1,54 | Reuse factor 2, 26 or 31 dBm, MIMO 1x4 |
| | DL | 3,19 | Reuse factor 2, 63 dBm |
| High speed (350 km/h, 4 km ISD) | UL | 1,54 | Reuse factor 2, 26 or 31 dBm, MIMO 1x4 |
| | DL | 2,14 | Reuse factor 2, 63 dBm |
| Urban (80 km/h, 2 km ISD) | UL | 1,91 | Reuse factor 3, 31 dBm, MIMO 1x4 |
| | DL | 1,62 | Reuse factor 3, 63 dBm |
| High density (80 km/h, 4 km ISD) | UL | 0,68 | Reuse factor 3, 31 dBm, MIMO 1x4 |
| | DL | 1,67 | Reuse factor 3, 63 dBm 63 dBm |
| Hilly (160 km/h, 8 km ISD) | UL | 0,32 | Reuse factor 3, 31 dBm, MIMO 1x4 |
| | DL | 2,39 | Reuse factor 3, 63 dBm |

NOTE 2: Values provided in tables of clause 5.1.3.3 include cyclic prefix, pilot and guard band overhead, i.e. an overhead of 9,52 % (symbol ratio 2/21) in DL and 14,3 % (symbol ratio 1/7) in UL, and a TDD ratio of 50/50 and 75/25 is applied.

Actual UL/DL percentages provided in clause 6.2.1 correspond to net UL/DL share over the total radio resources, and include already cyclic prefix, pilot and guard band overhead.

To compute the net throughput of Table 49 from values provided in tables of clause 5.1.3.3, values are first scaled up to 100 % resources, then resources corresponding to cyclic prefix, pilot and guard band overhead are added before applying the actual percentage provided in clause 6.2.1.

7 Conclusion

The assumptions considered in the present document have been chosen to be stringent in order to test the system at its limits. In particular, a radio channel with a higher Rice factor (LOS component), which would lead to increased performance, could be encountered in the field.

For 900 MHz carrier frequency:

Result set 3 includes a full LTE stack and provides net throughput values, but interferences from neighbours are not considered.

Result set 1 shows that interference can be a limiting factor if cells are operated in a frequency reuse 1 scheme and are fully loaded. However, LTE system has some flexibility in radio resource assignment and several interference mitigation techniques could be implemented, for example fractional frequency reuse. Therefore, and considering that 50 % load instead of 100 % load in all neighbouring cells is a more realistic assumption, it could be expected to have a minimum throughput at cell edge corresponding to results provided for frequency reuse 2 or 3 schemes.

Considering the two sets of results, a throughput in UL and DL in the range 0,3 - 0,4 Mbit/s could be expected in a hilly environment as minimum guaranteed bit rate at handover point in a railway deployment, with a 1,4 MHz spectrum bandwidth in the 900 MHz band. This throughput is to be shared by trains served by the cell. Thanks to resource re-use techniques, this throughput could be made available at the same time on both sides of each site which could result in an increase of the total capacity available. With 5 MHz of bandwidth, this minimum guaranteed throughput could reach 1,3 Mbit/s in UL and 1,4 Mbit/s in DL.

In rural radio environment at high speed (360 km/h), a minimum guaranteed bit rate around 1 Mbit/s could be expected at handover point in UL or in DL with a 1,4 MHz spectrum bandwidth in the 900 MHz band. With 5 MHz of spectrum bandwidth, a minimum guaranteed bit rate in the range 3,5 - 6,0 Mbit/s could be expected.

For 1 900 MHz carrier frequency:

Impact of speed is more important compared to 900 MHz. This can be seen in cell centre, and in cell edge performance as well.

Interference remains a limiting factor as most of the scenarios need an interference mitigation technique to avoid interference (e.g. frequency reuse 2 in rural scenario and frequency reuse 3 in urban scenario).

For rural scenarios with high ISDs (8 and 6 km), 23 dBm transmit power is not sufficient to achieve sufficient UL data throughput (noise limited situation) however minimum guaranteed performance can reach 1.5 Mbit/s in 75/25 TDD when 31 dBm transmit power is used. Downlink net guaranteed throughput up to 3,1 Mbit/s in 75/25 TDD and 63 dBm EIRP can be achieved with appropriate interference mitigation.

In urban scenario (2 km ISD), cell edge downlink minimum guaranteed performance of 1,6 Mbit/s in 75/25 TDD is achievable while this performance is around 1,9 Mbit/s in UL. The uplink is still limited by speed even if the impact is much lower compared to rural scenario.

In high density scenario (4 km ISD), downlink minimum guaranteed performance is similar to urban scenario while in uplink the minimum guaranteed performance is limited to 0,7 Mbit/s in the best case (75/25 TDD).

In Hilly scenario (8 km ISD), downlink minimum guaranteed performance with 63 dBm can reach 2,4 Mbit/s (75/25 TDD). While in uplink the minimum guaranteed throughput is very 10,3 Mbit/s. To achieve a higher UL throughput, a lower ISD and/or a higher UL transmit power would be necessary.

In general, one can observe at 1 900 MHz that uplink performance is much lower than downlink performance. Indeed, the difference in uplink and downlink reference signals design in LTE makes the channel estimation more sensitive to time variations in uplink compared to downlink.

Minimum guaranteed performance at 900 MHz is in general higher than what can be achieved at 1 900 MHz (considering 5 MHz bandwidth in FDD at 900 MHz and 10 MHz bandwidth in 50/50 TDD at 1 900 MHz). This can be explained by a better link budget at 900 MHz and by the Doppler effect which is much higher at 1 900 MHz (twice maximum Doppler shift).

Annex A: Theoretical peak throughput for LTE

Table A.1 provides the peak data rates at physical layer that are theoretically achievable by an LTE radio operating on a 1,4 MHz bandwidth, considering no packet loss (PER = 0), 64 QAM modulation, normal cyclic prefix and the following transmission schemes:

- The 2x2 MIMO transmission scheme is the Alamouti Space Frequency Block Code (SFBC) applied on two adjacent sub-carriers.
- The 4x2 MIMO transmission scheme is a combination of Alamouti SFBC and Frequency Switched Transmit Diversity (FSTD) on four adjacent sub-carriers.

Those transmission schemes have been selected among all schemes proposed by LTE standard for their high transmit diversity properties, which make them more robust to the high train velocity.

Table A.1: Some maximum theoretical throughputs for LTE physical layer operating in a 1,4 MHz bandwidth

| Max. theoretical throughput (Mbit/s) | DL | | UL |
|--|------------|------------|------|
| | 2x2 (SFBC) | 4x2 (FSTD) | SIMO |
| Without control signalling overhead | 4,92 | 4,67 | 4,67 |
| With control signalling overhead (2 OFDM symbols for PDCCH in DL, 2 PRBs for PUCCH in UL) | 4,75 | 4,61 | 3,46 |

In DL, 4x2 transmission scheme has a peak throughput lower than 2x2 due to the increased pilot overhead (9,52 % for 2x2 against 14,29 % in 4x2), but is expected to be more resistant under bad radio conditions.

Annex B: Throughput curves for simulation results set 1

B.1 First round of simulations (900 MHz)

High speed scenario

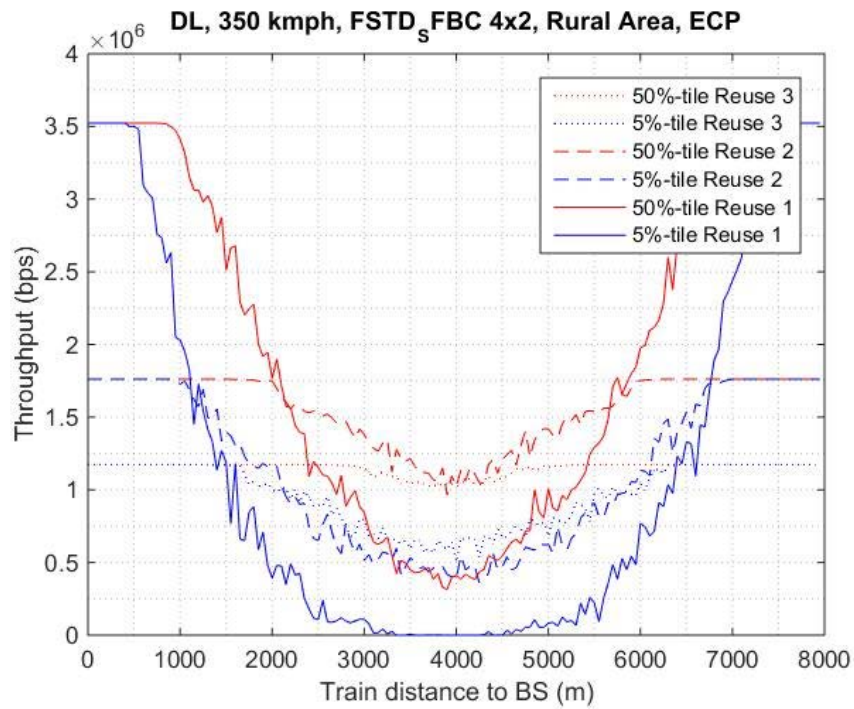

Figure B.1

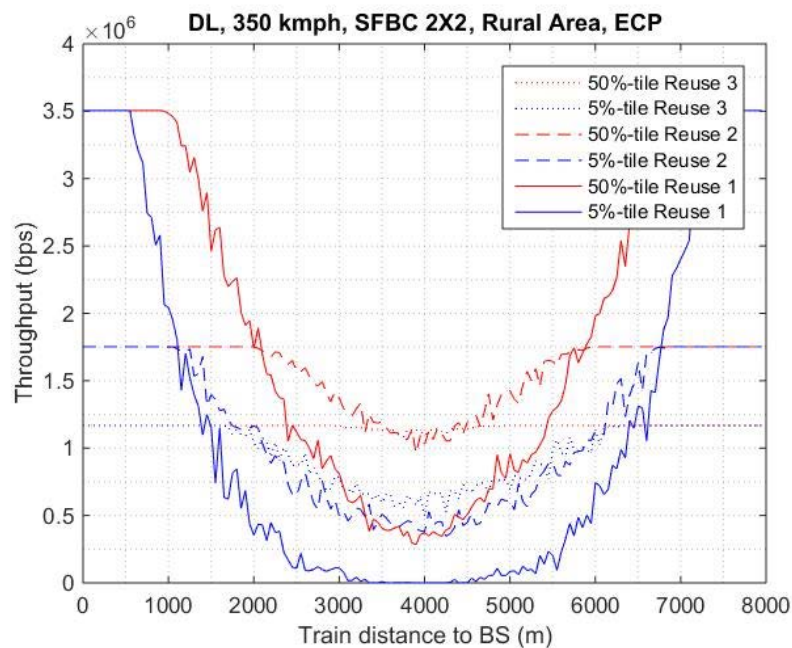

Figure B.2

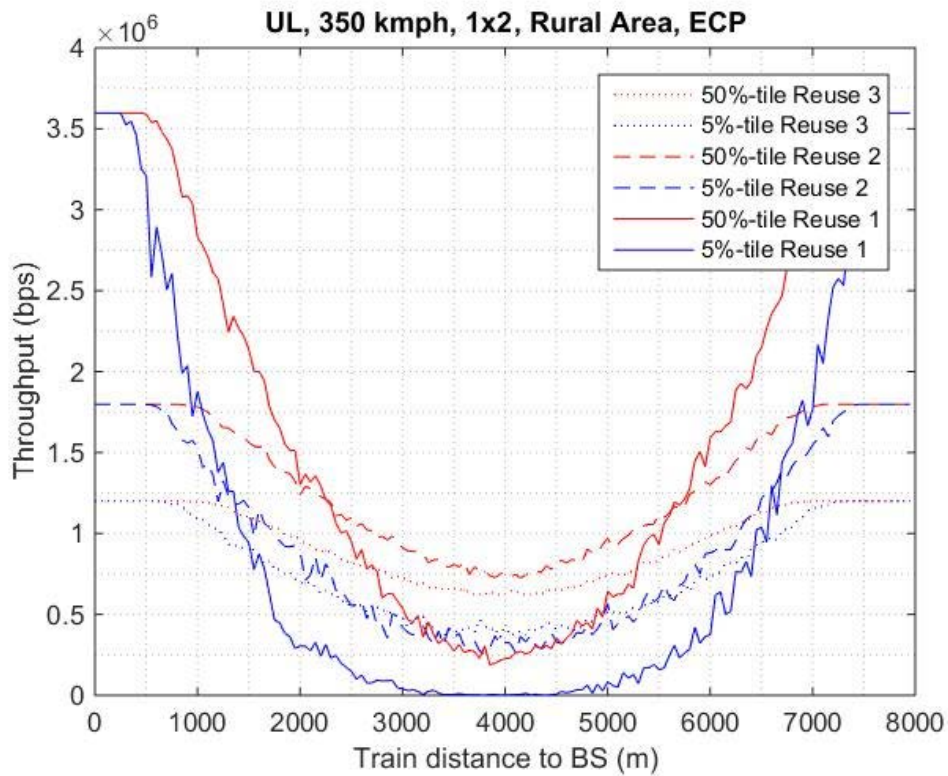

Figure B.3

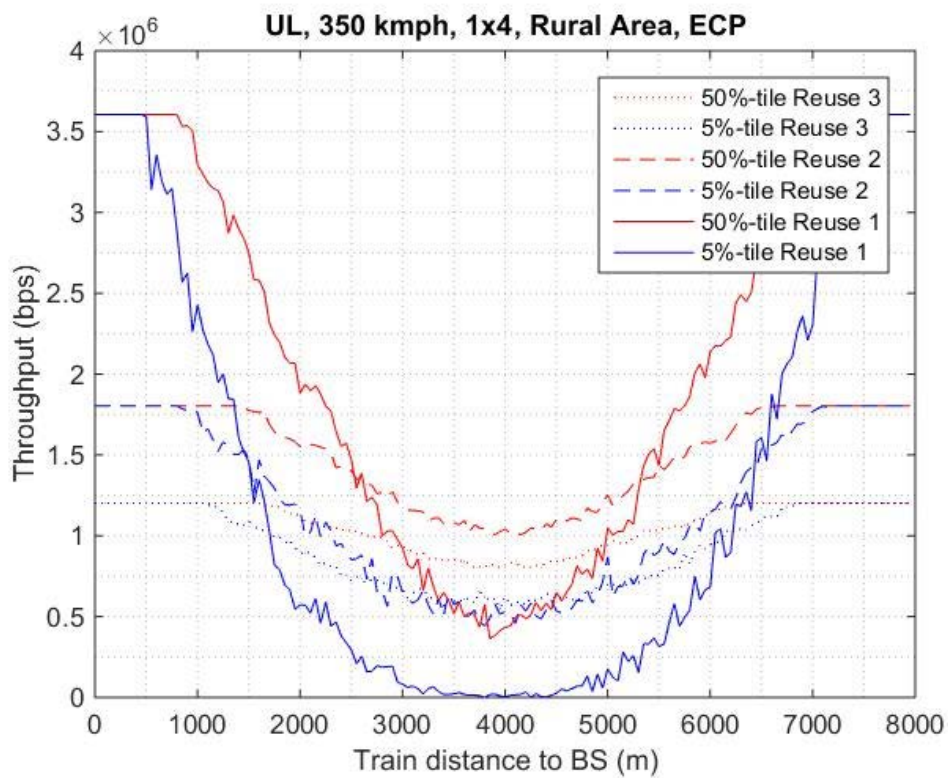

Figure B.4

Urban scenario

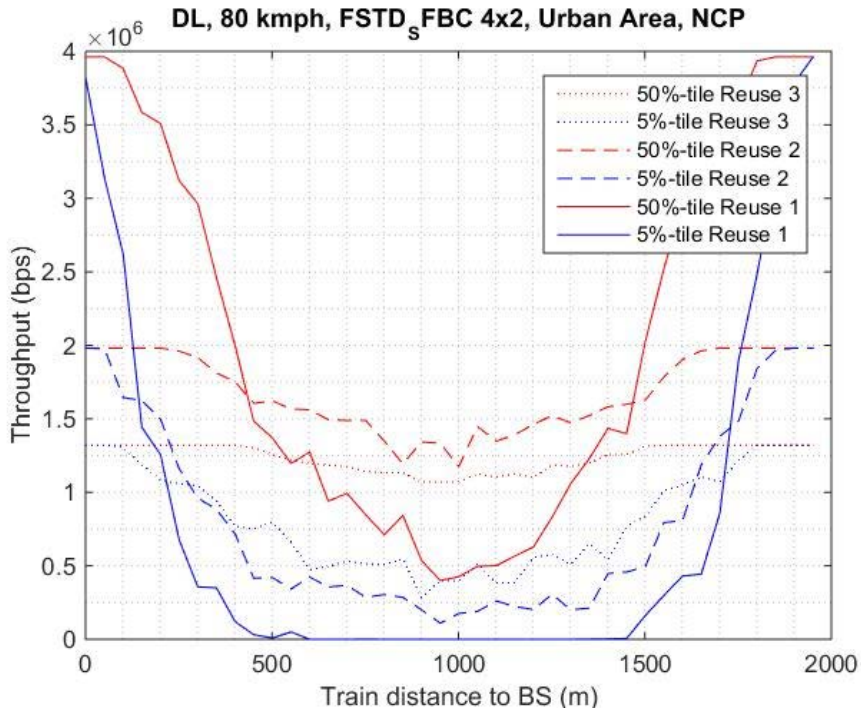

Figure B.5

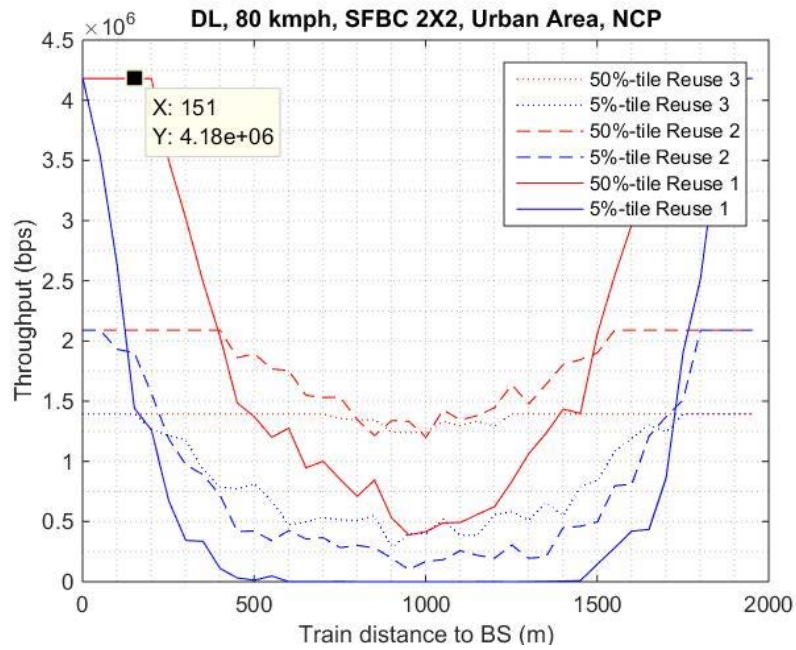

Figure B.6

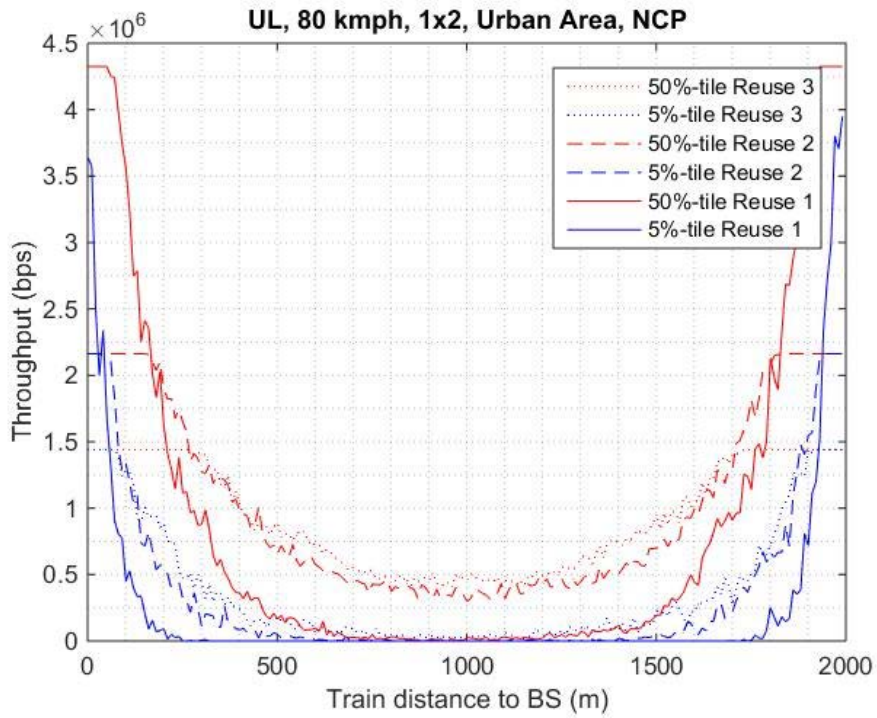

Figure B.7

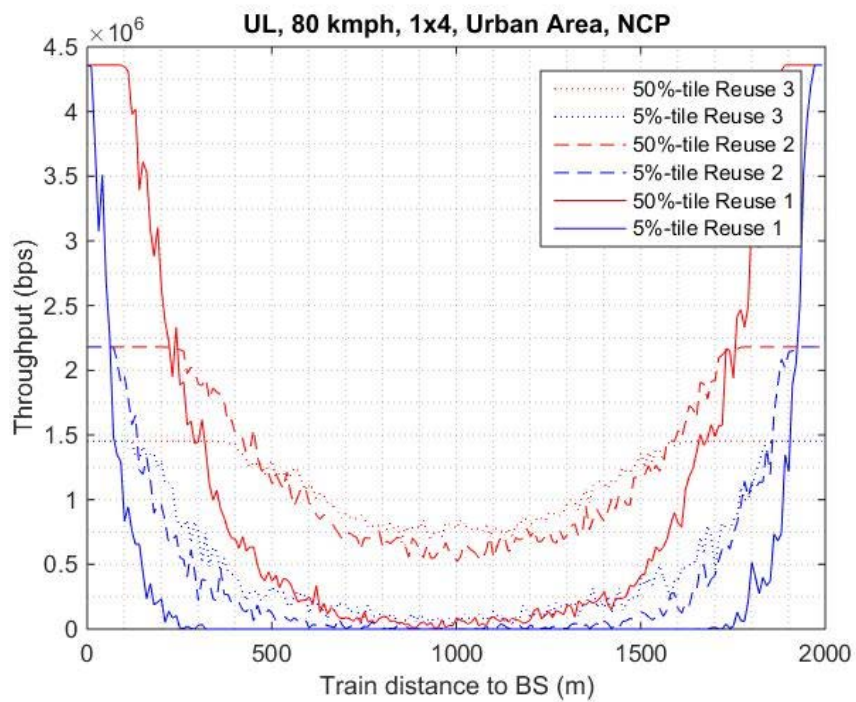

Figure B.8

High density scenario

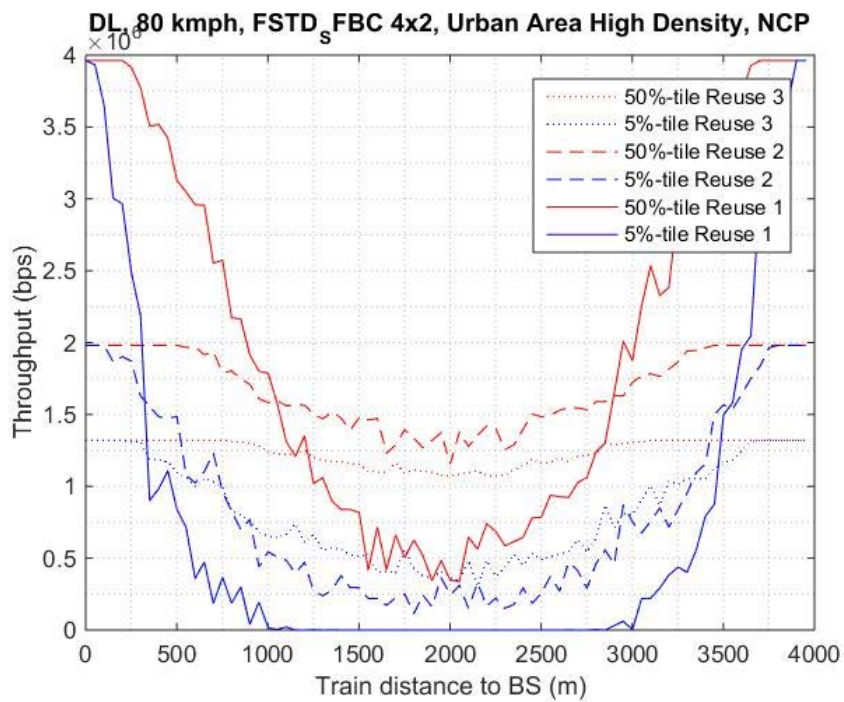

Figure B.9

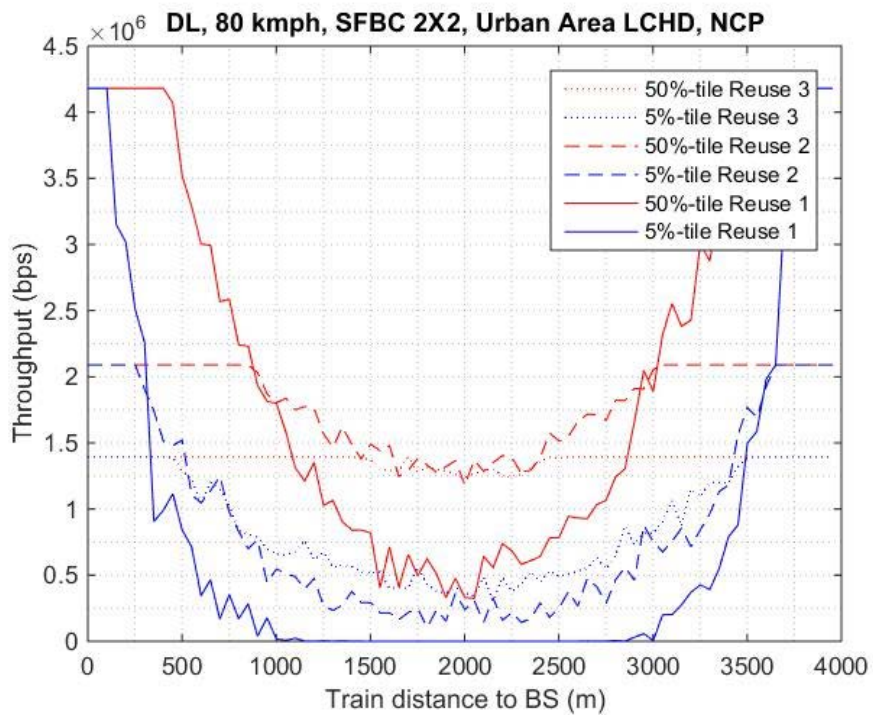

Figure B.10

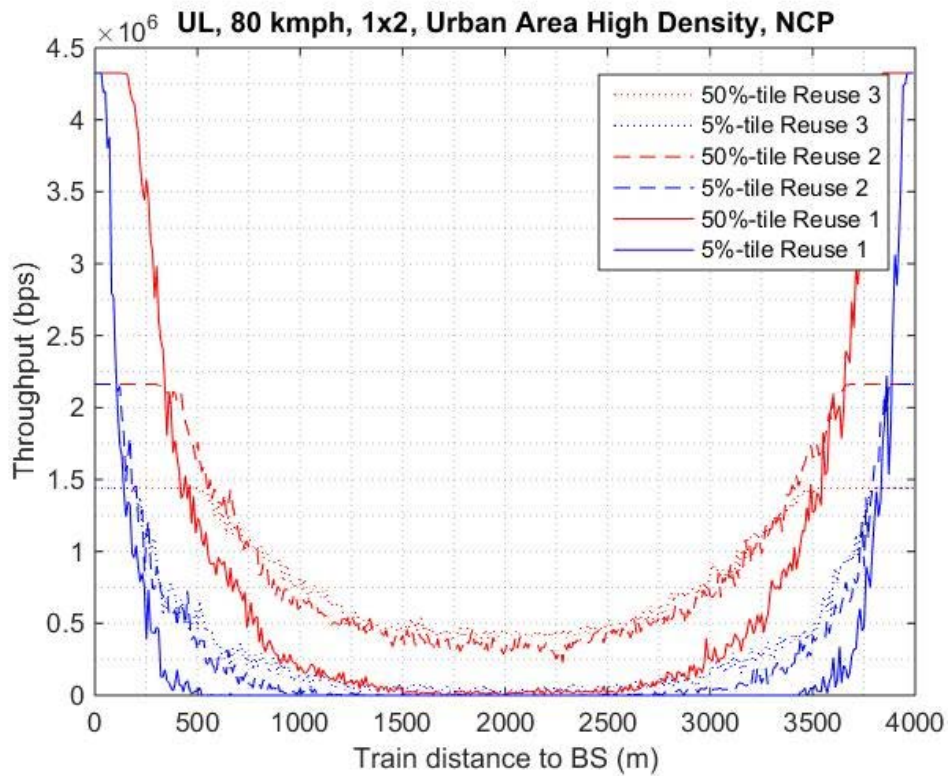

Figure B.11

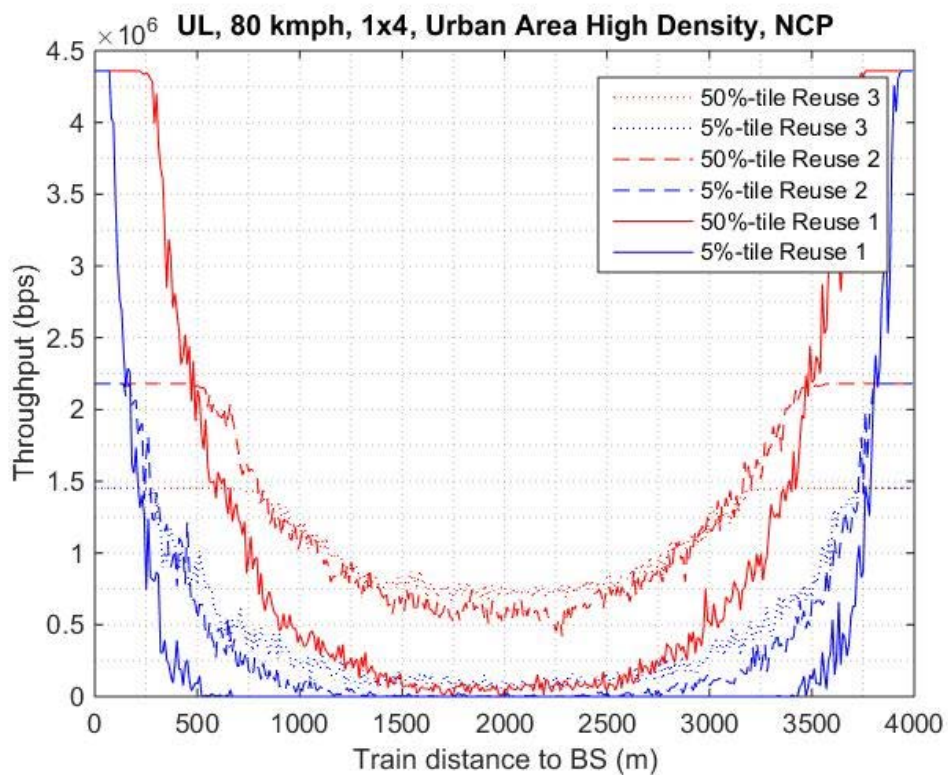
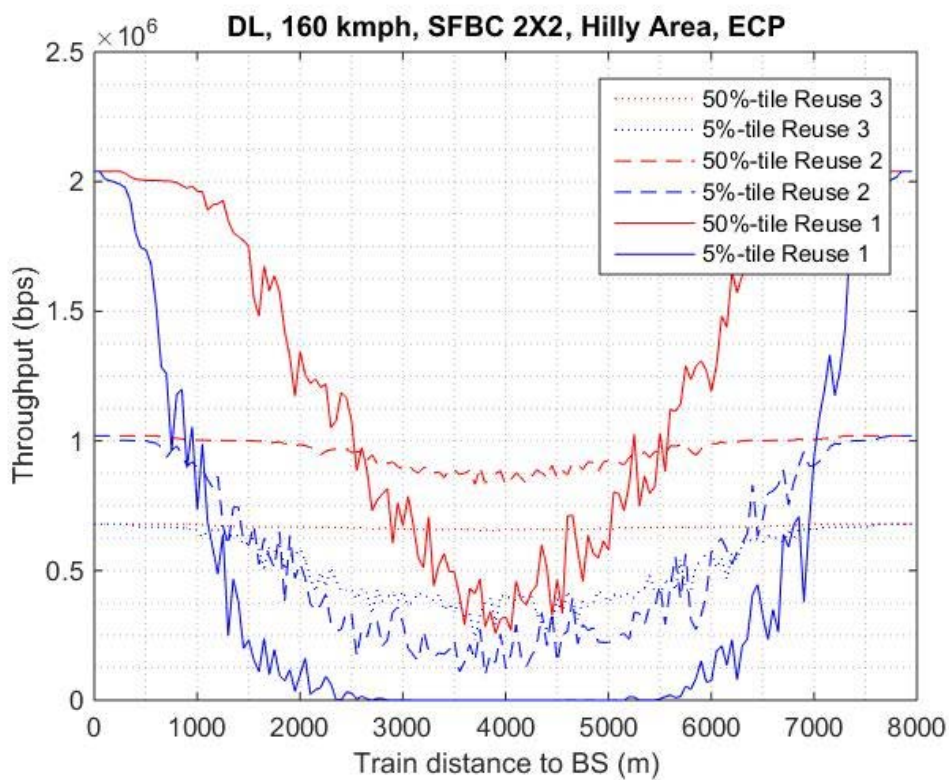
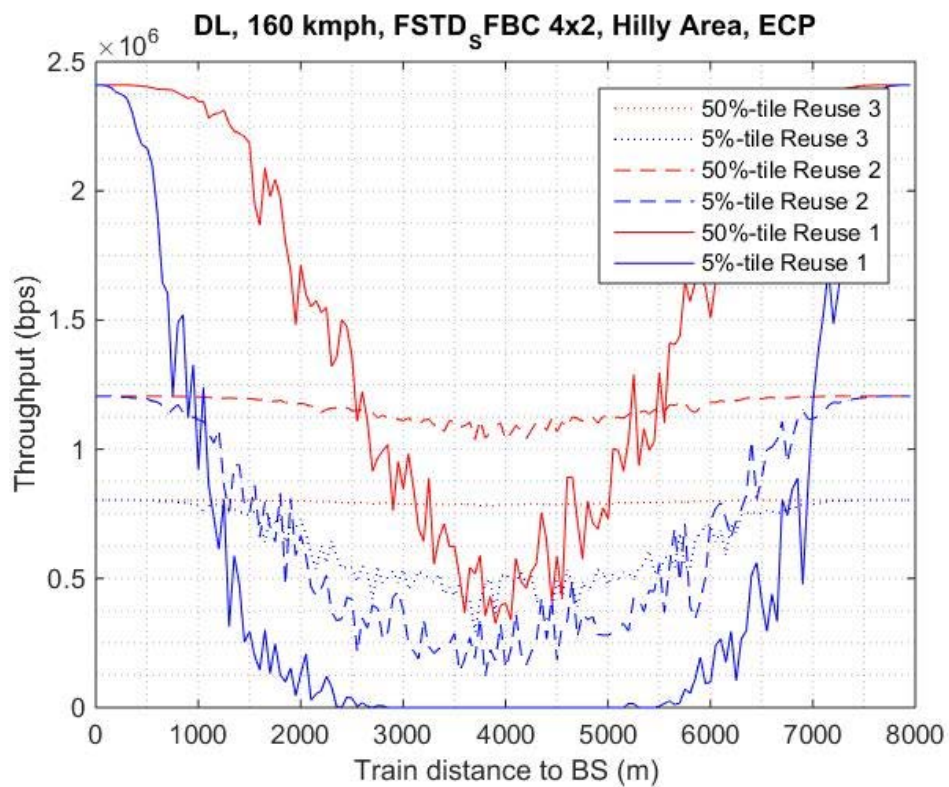
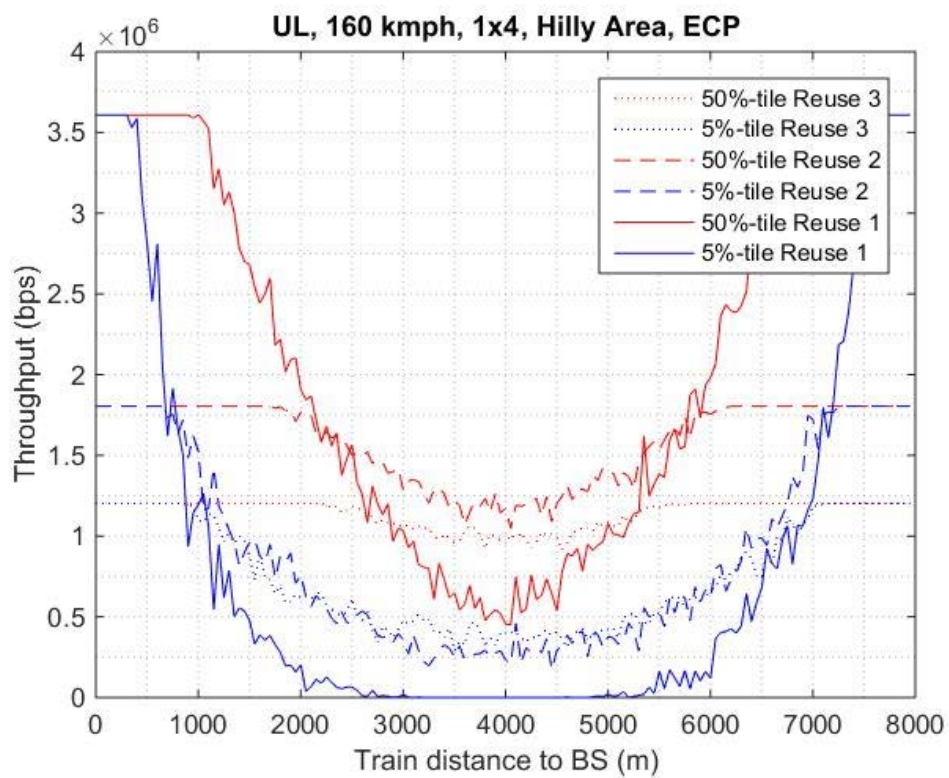
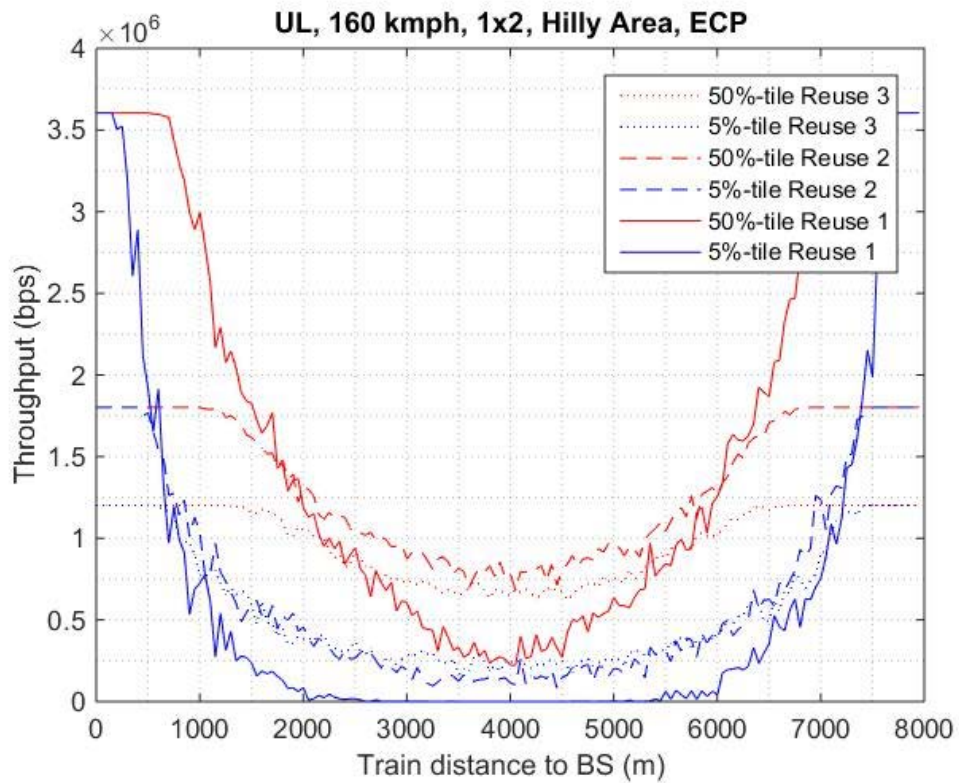

Figure B.12

Hilly scenario





Urban scenario with antenna tilt of 5°

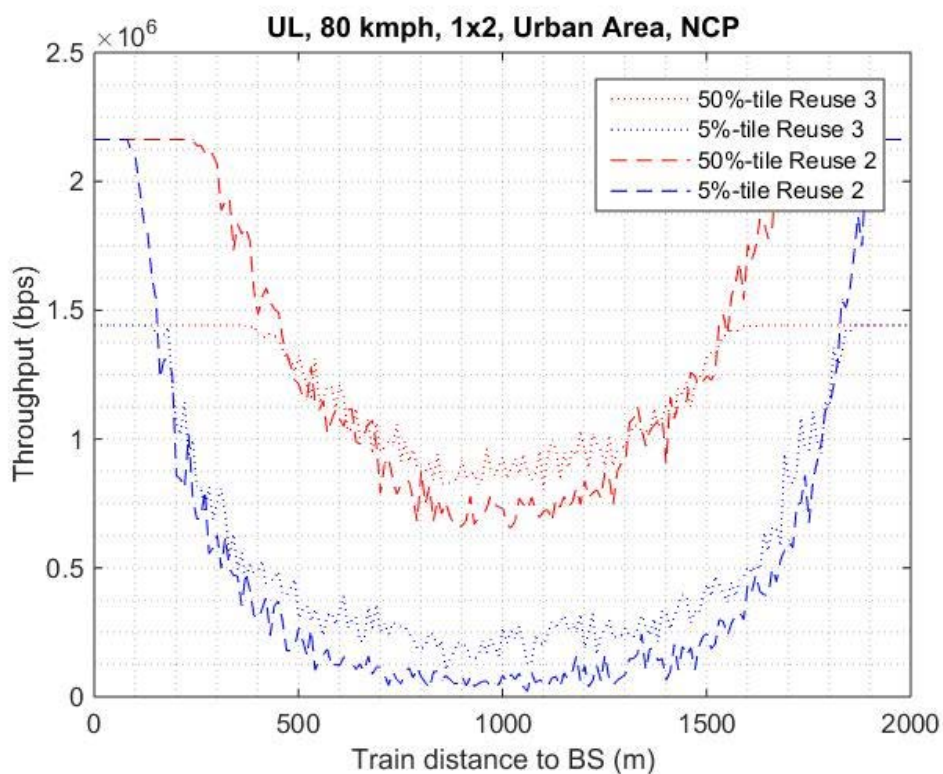

Figure B.17

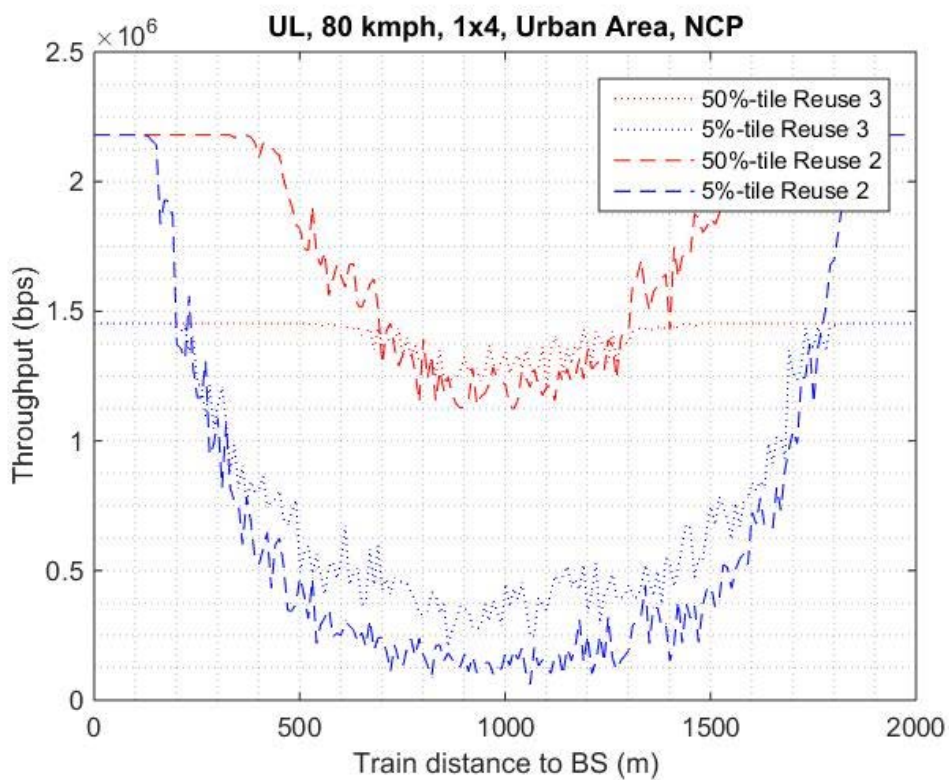

Figure B.18

B.2 Second round of simulations (900 MHz)

Results at 1,4 MHz

High speed scenario

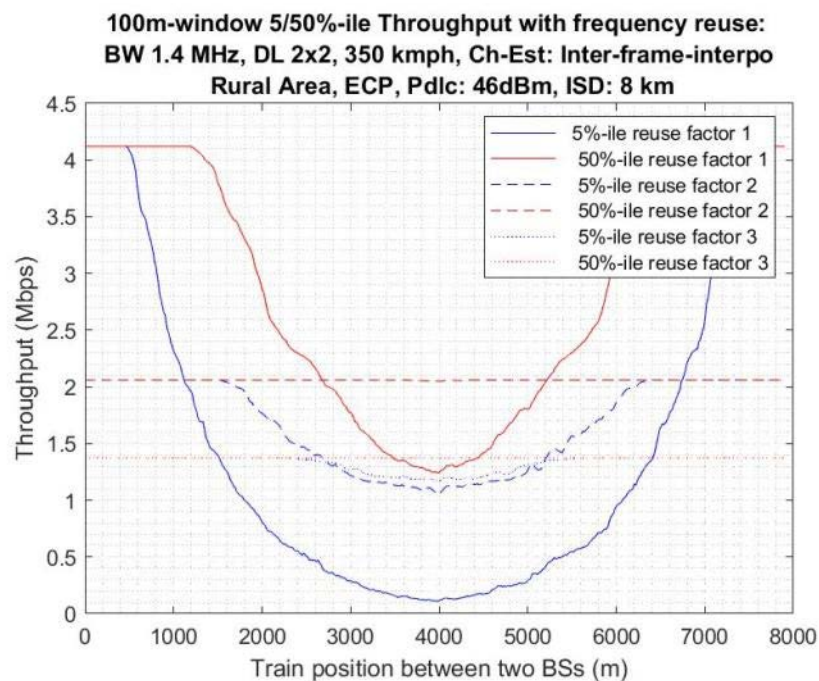

Figure B.19

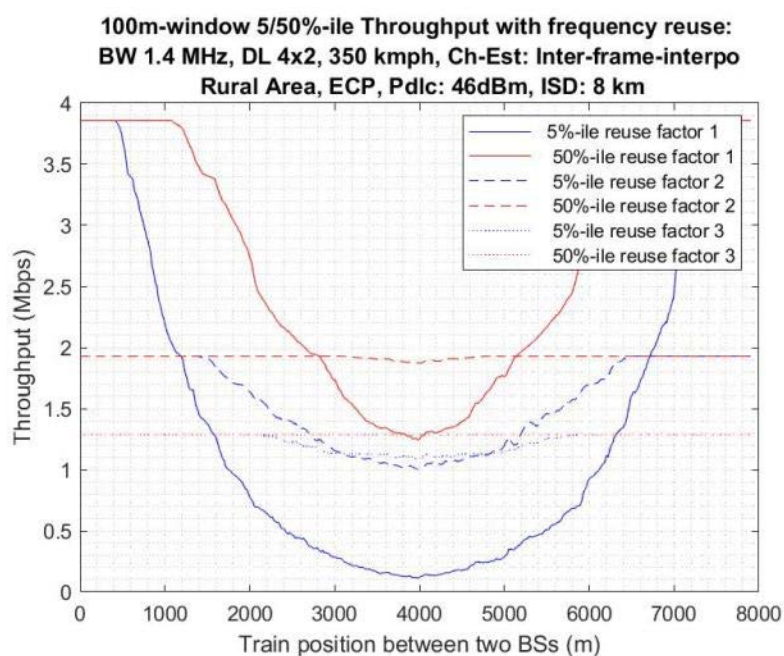

Figure B.20

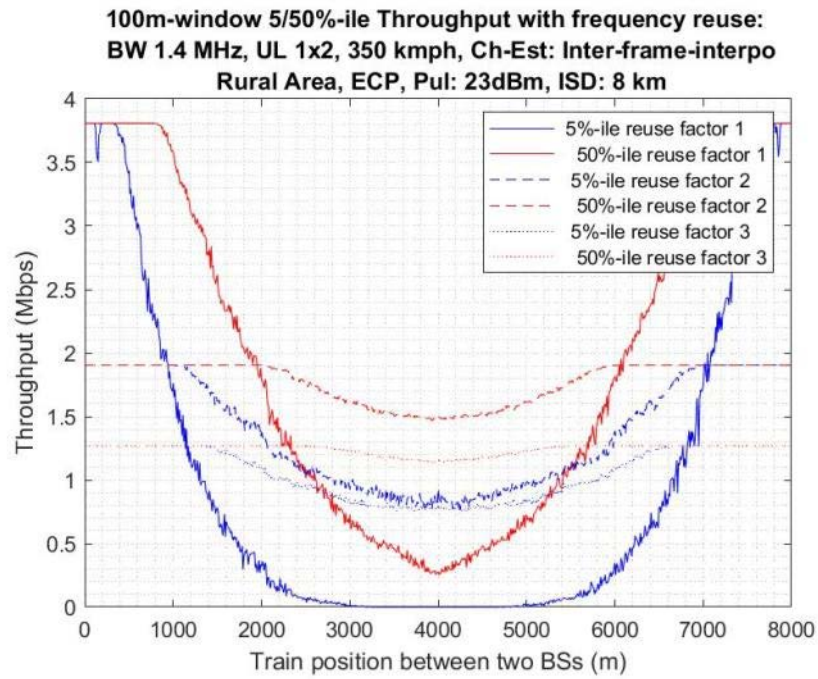

Figure B.21

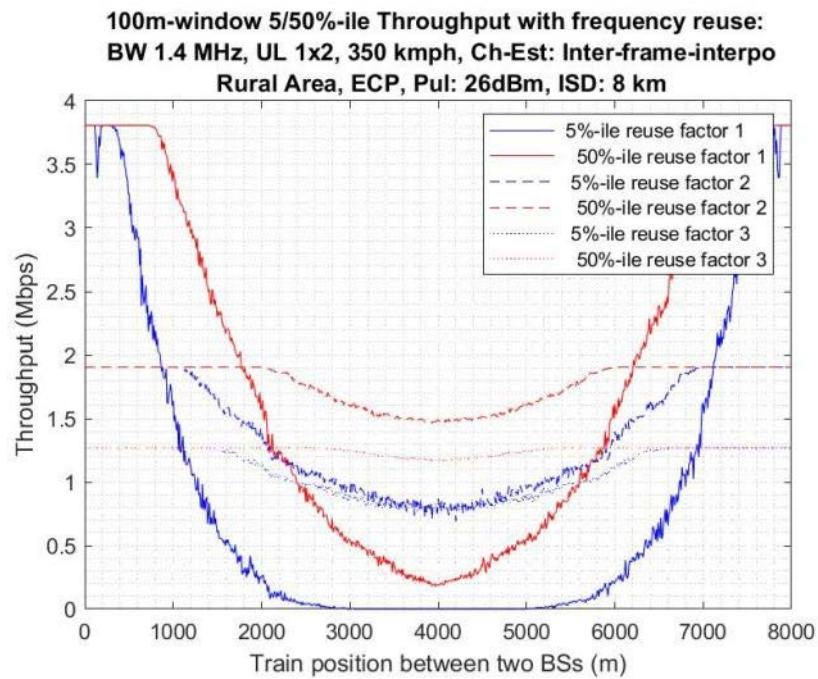

Figure B.22

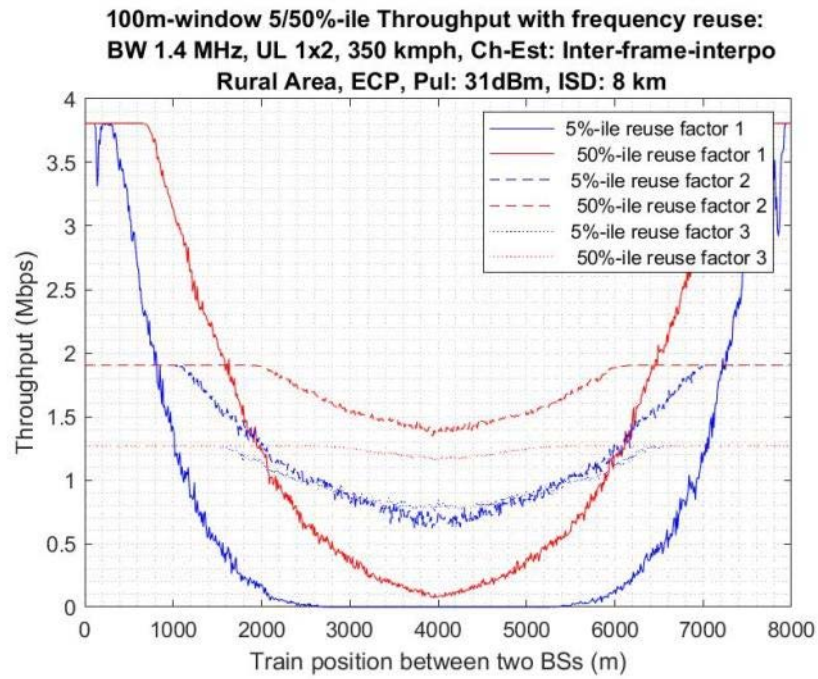

Figure B.23

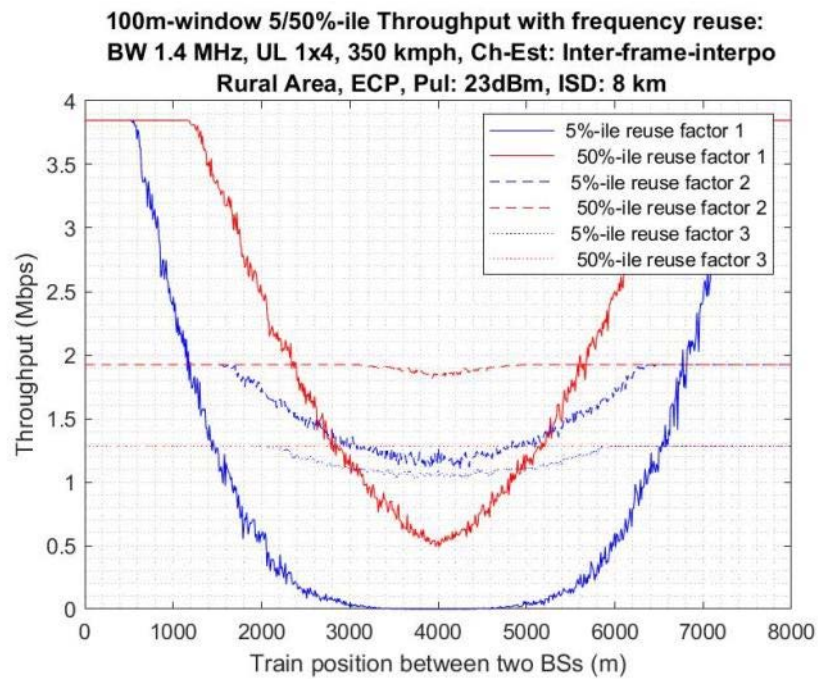

Figure B.24

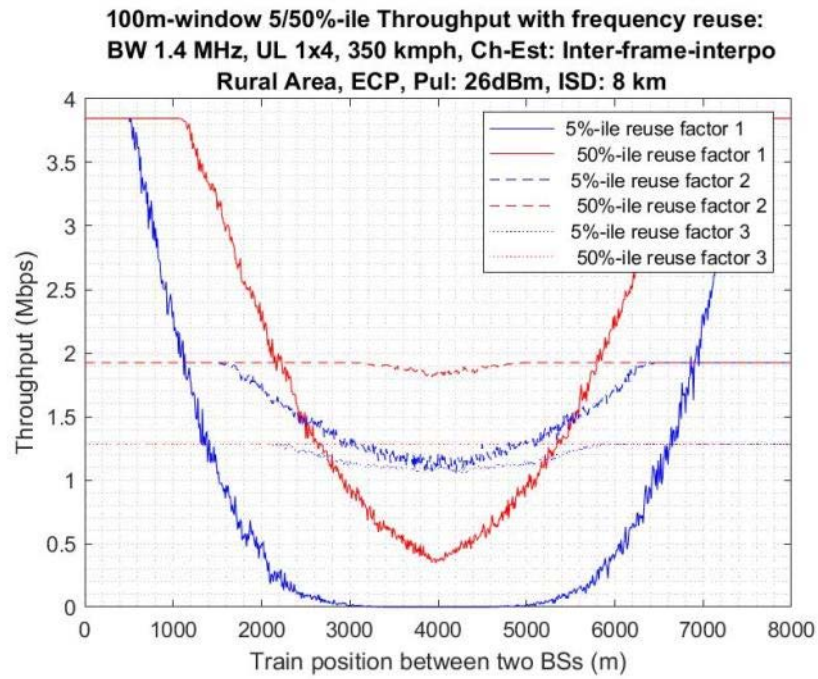

Figure B.25

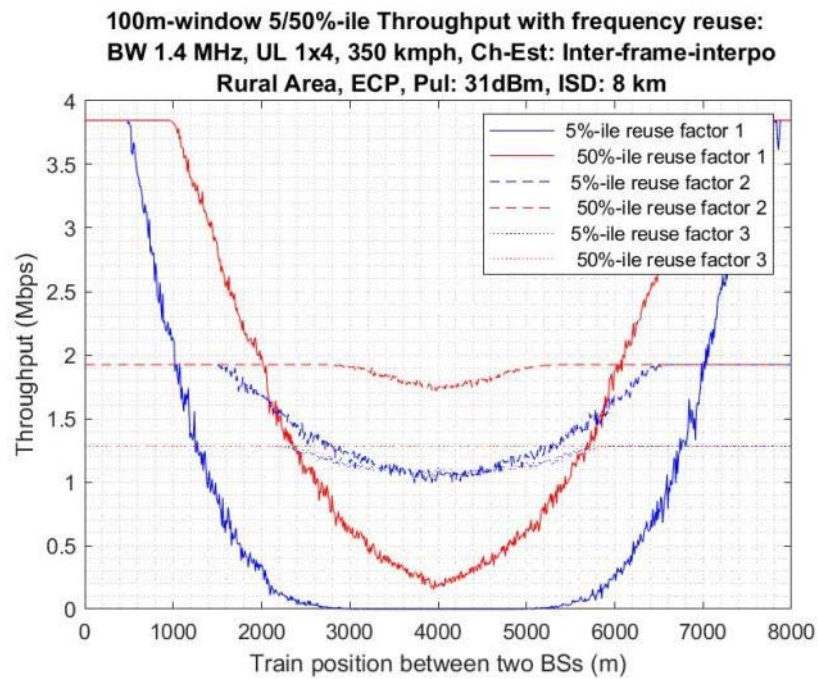

Figure B.26

Hilly scenario

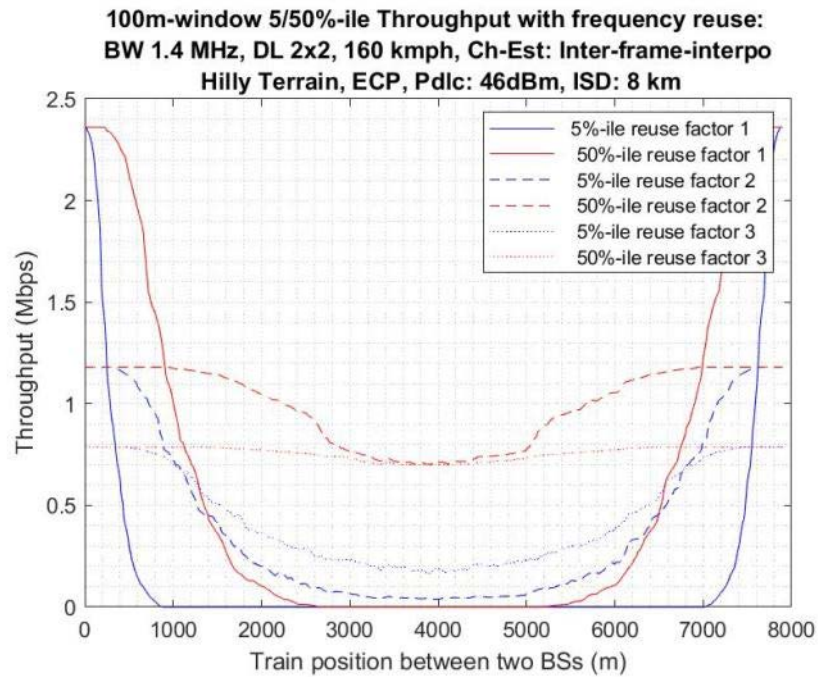

Figure B.27

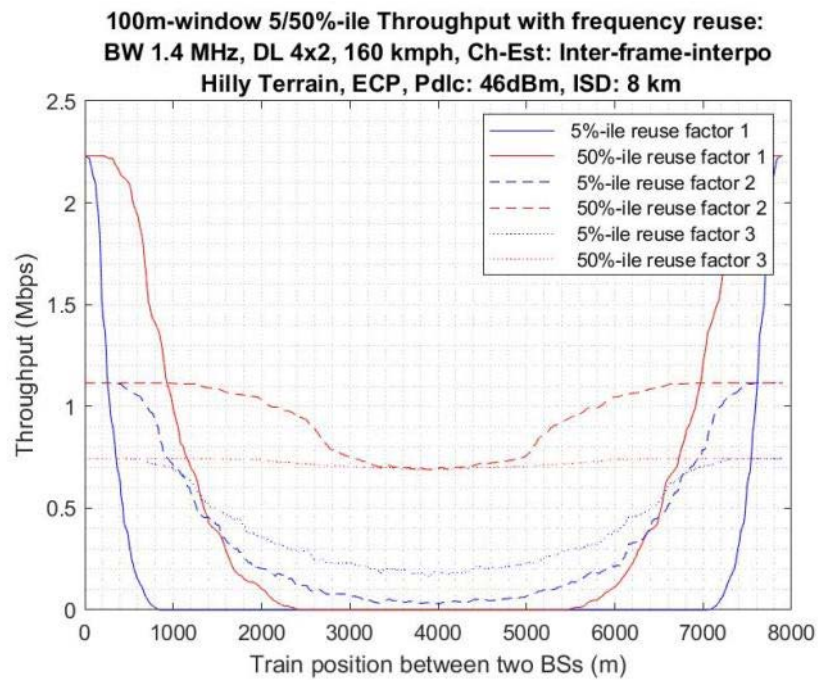

Figure B.28

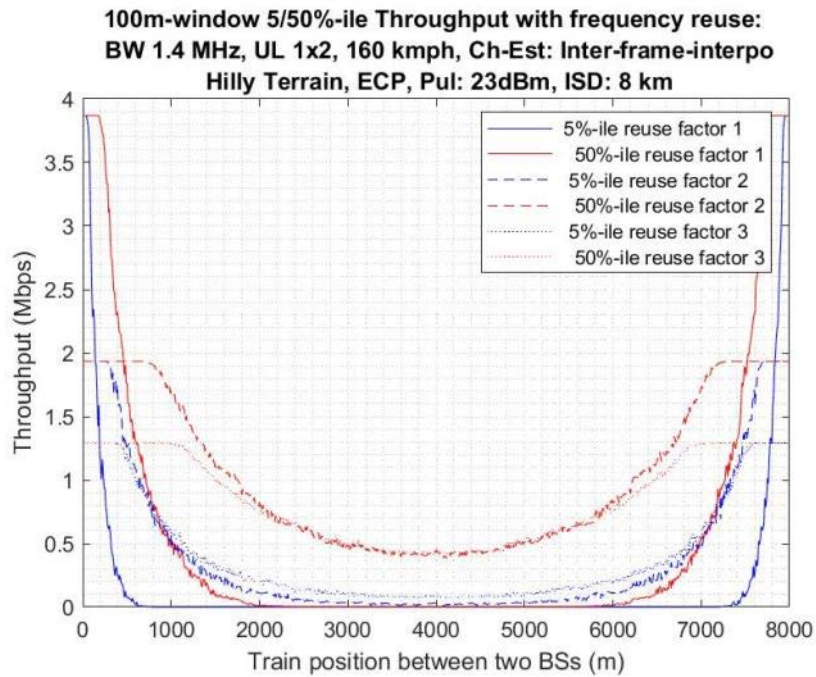

Figure B.29

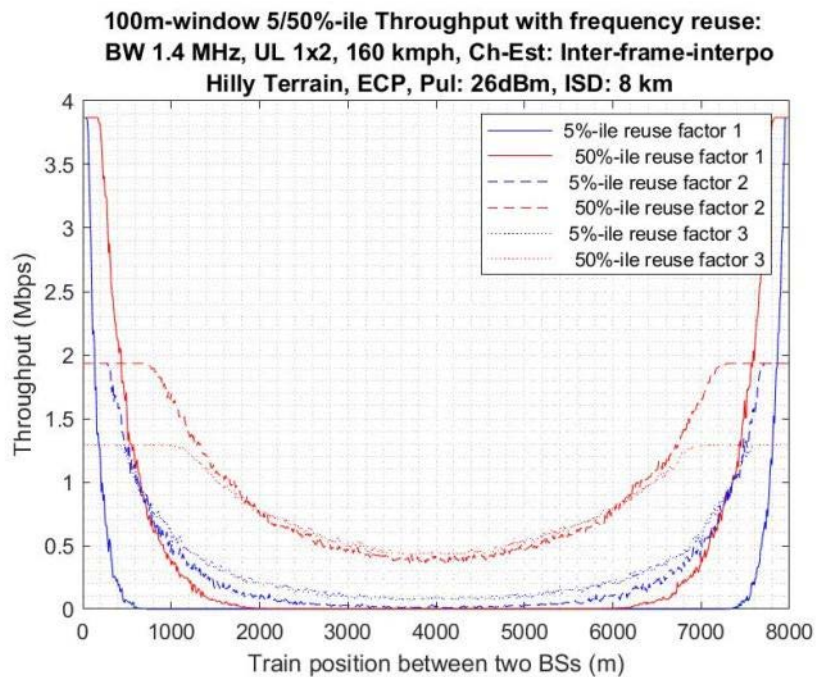

Figure B.30

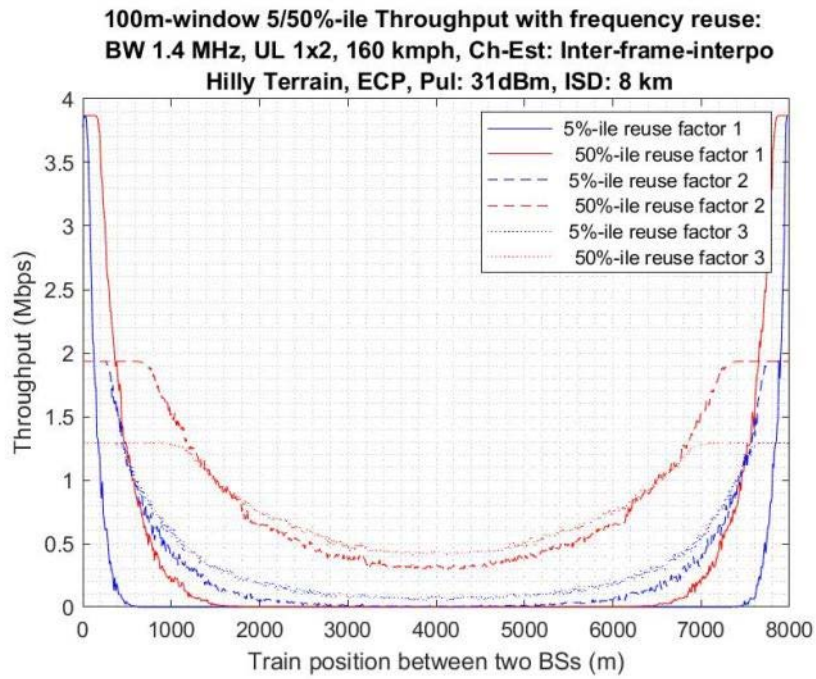

Figure B.31

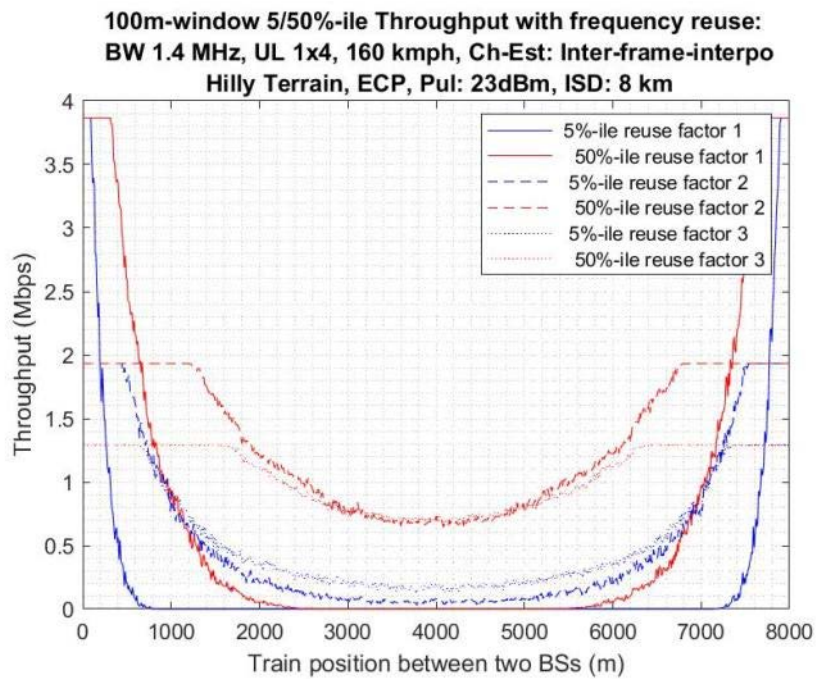

Figure B.32

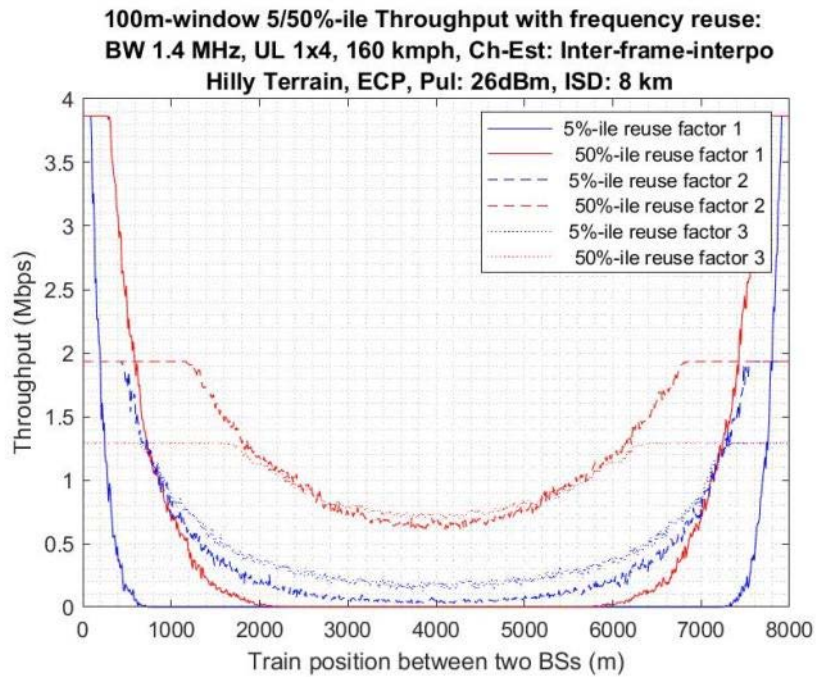

Figure B.33

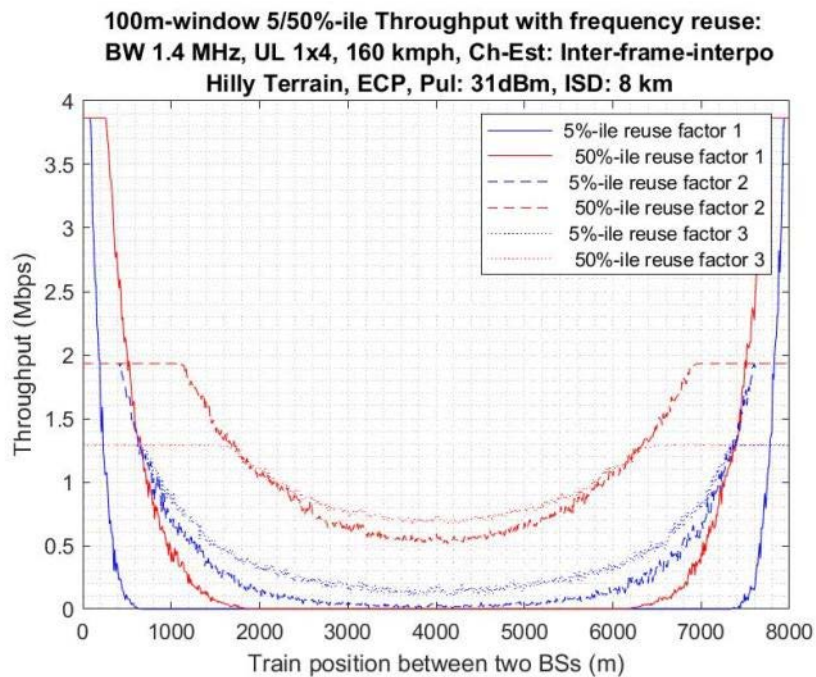

Figure B.34

Urban scenario

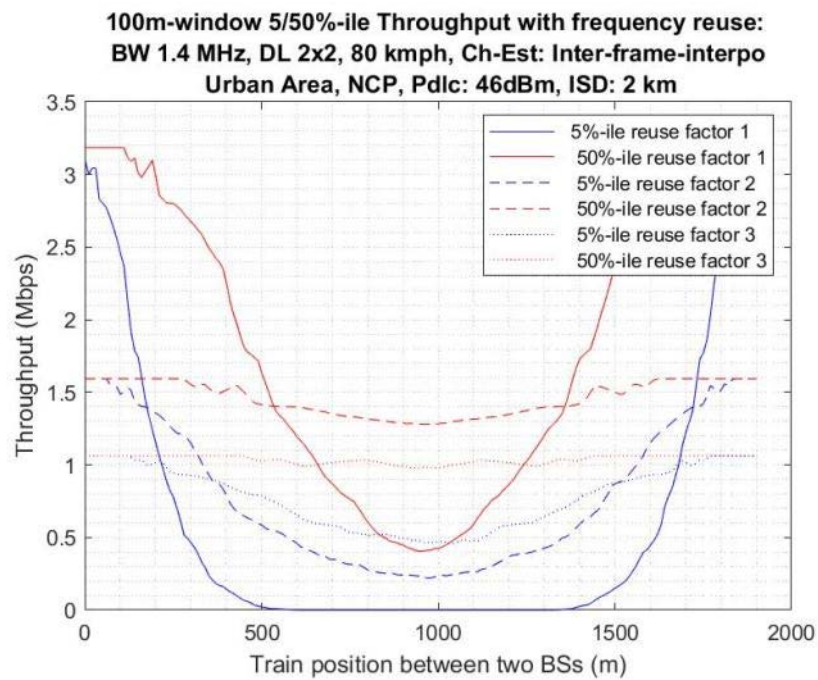

Figure B.35

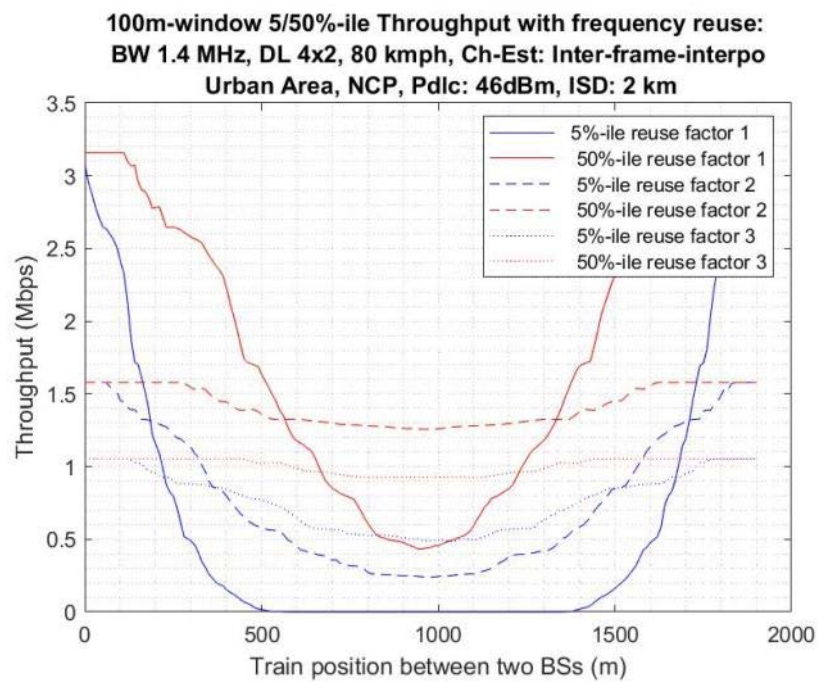

Figure B.36

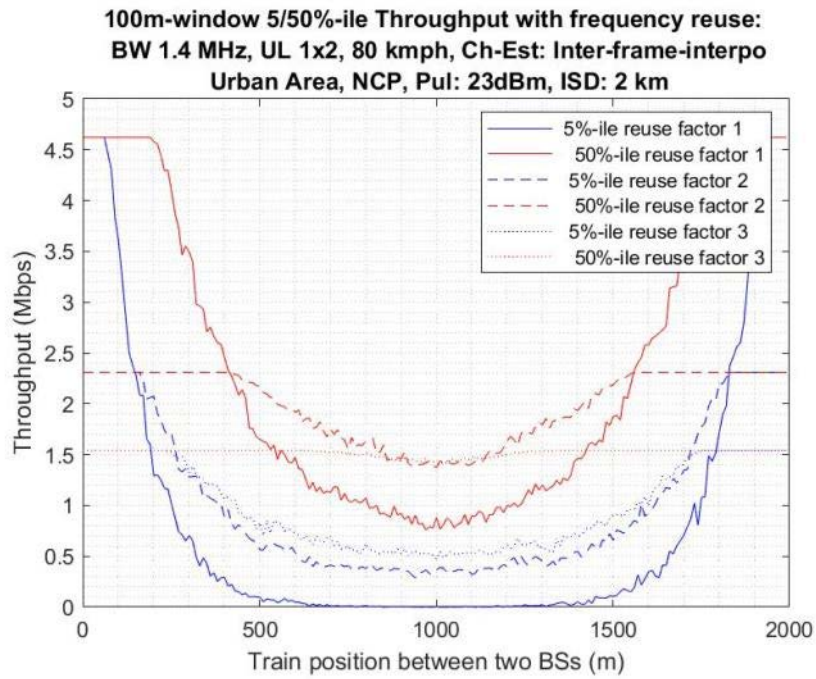

Figure B.37

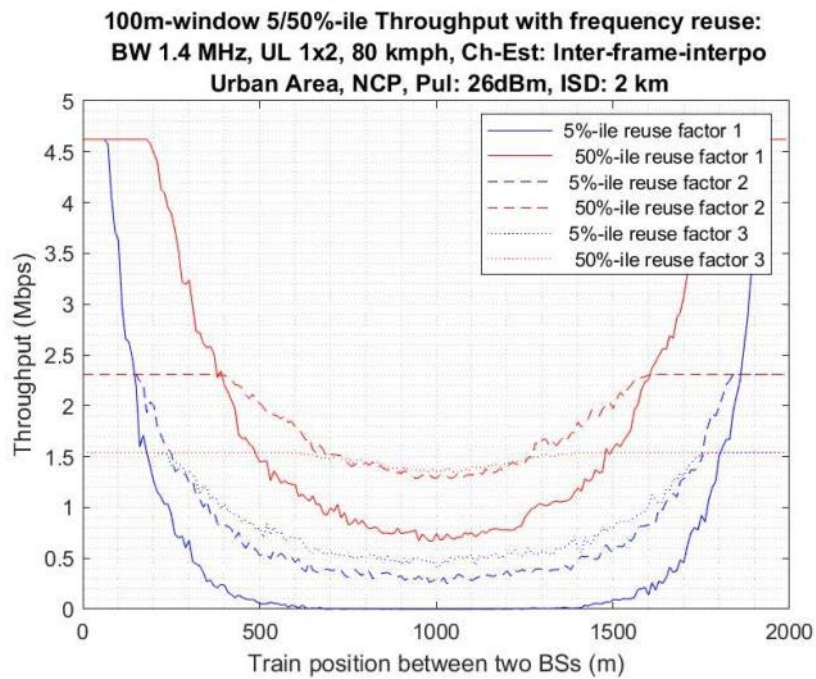

Figure B.38

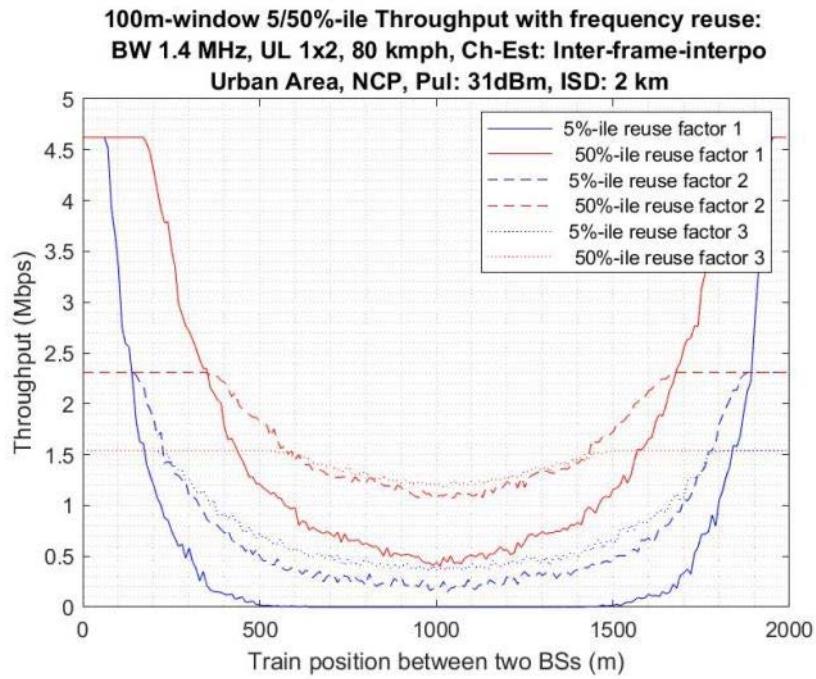

Figure B.39

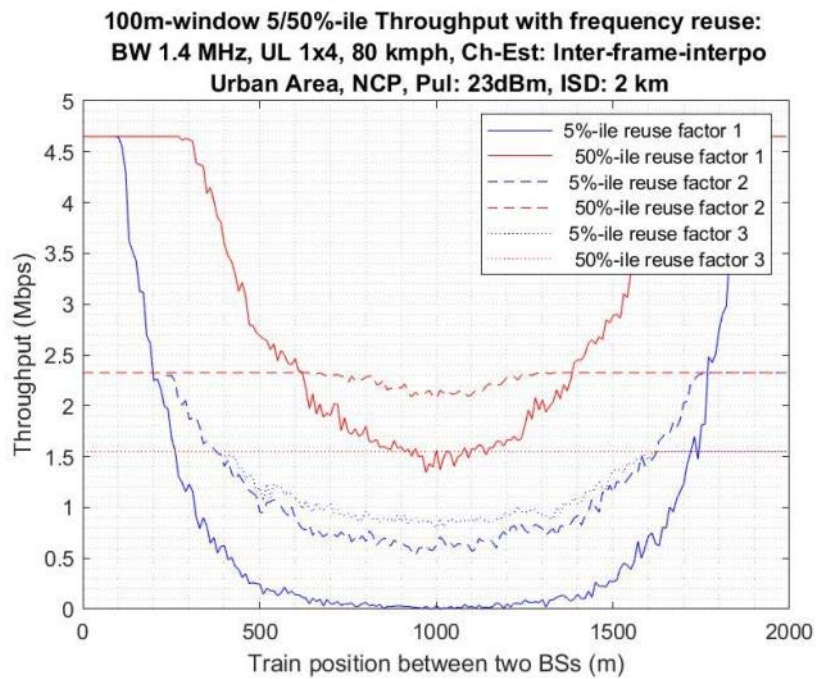

Figure B.40

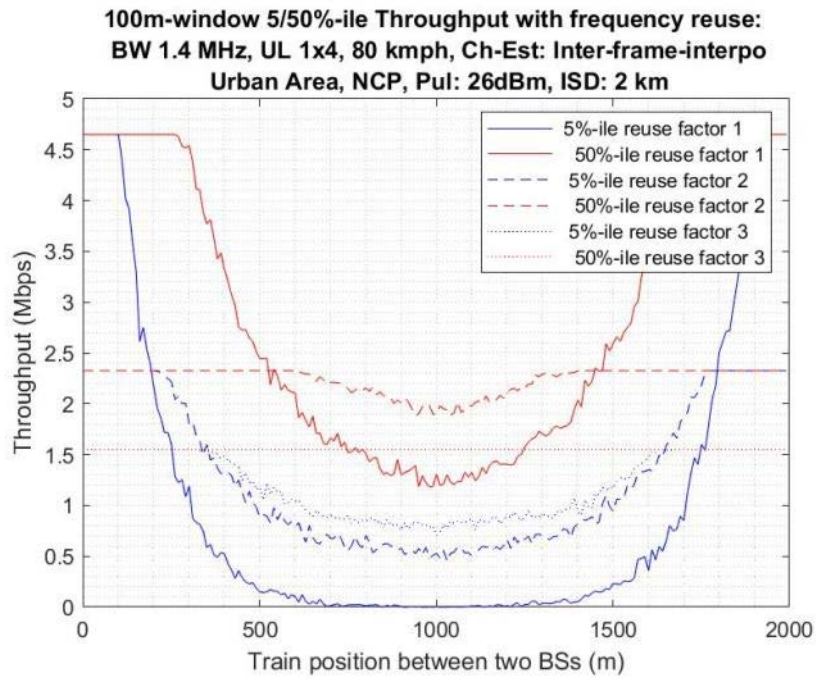

Figure B.41

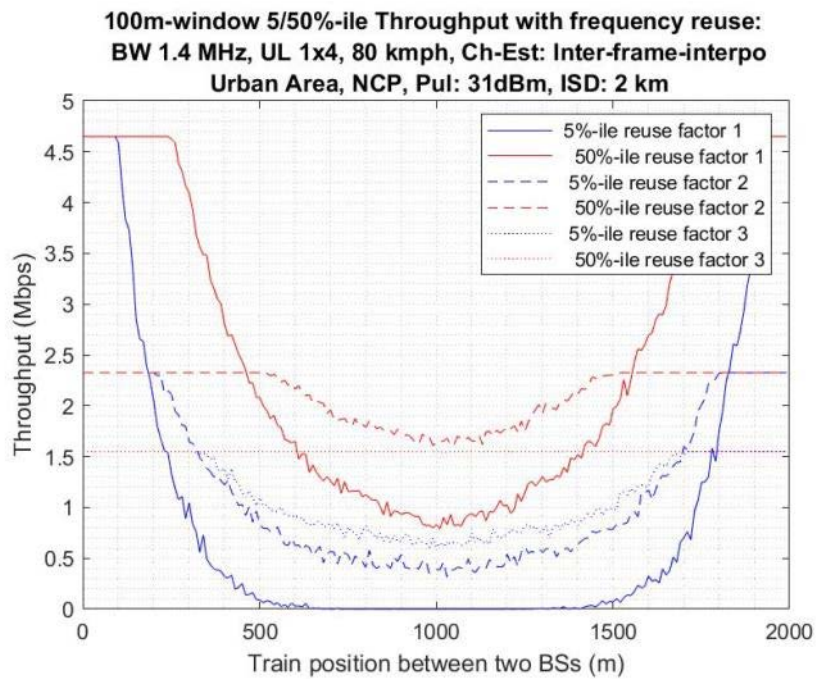

Figure B.42

High density scenario

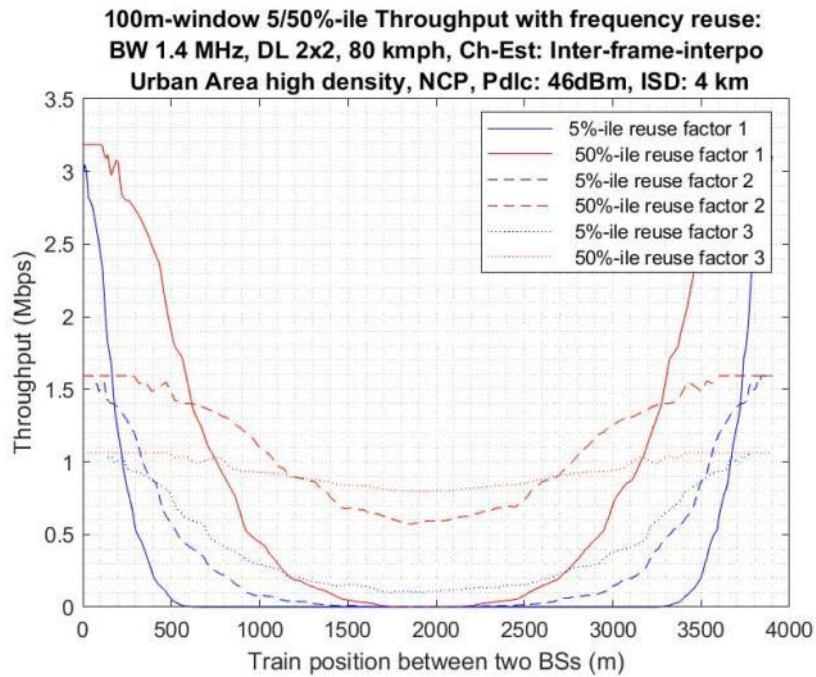

Figure B.43

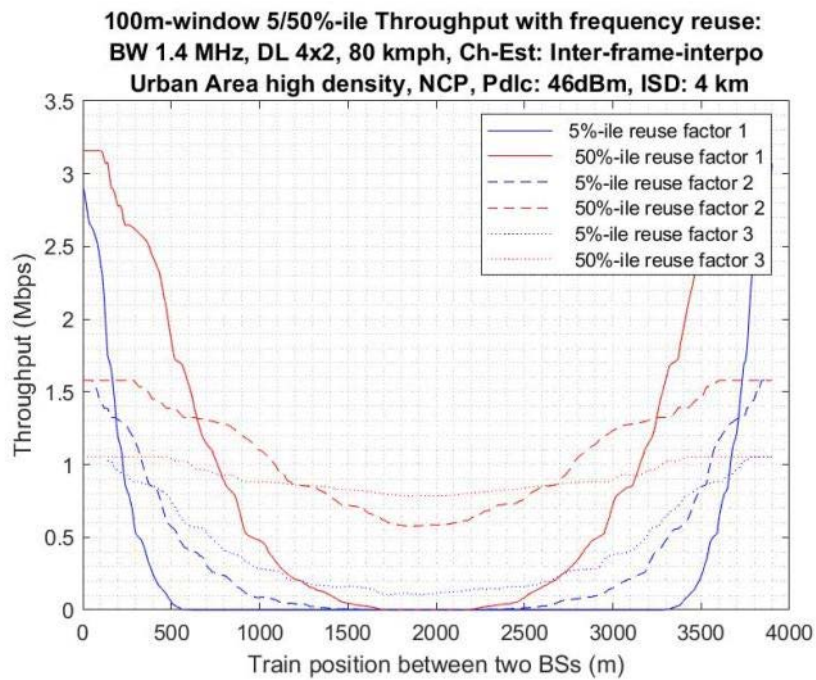

Figure B.44

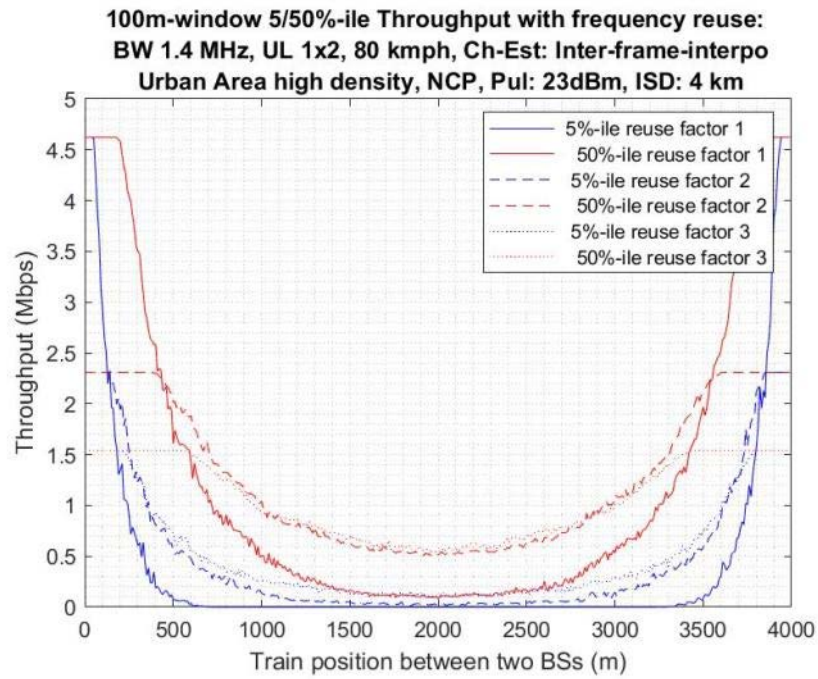

Figure B.45

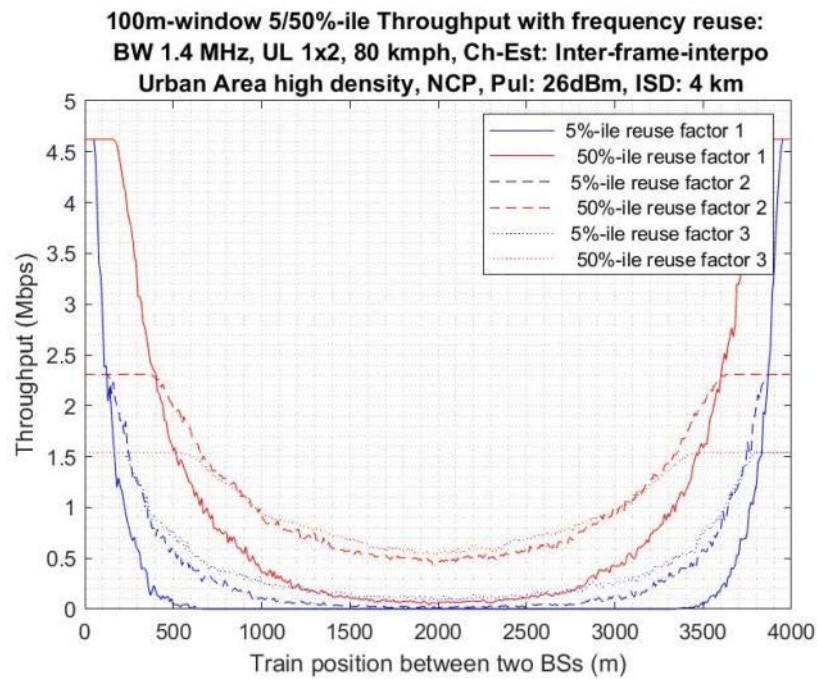

Figure B.46

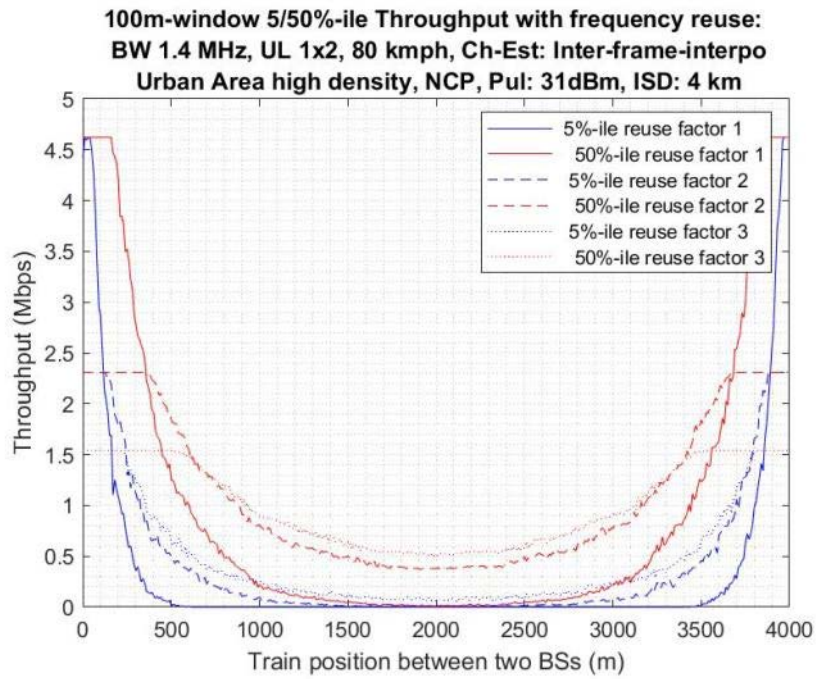

Figure B.47

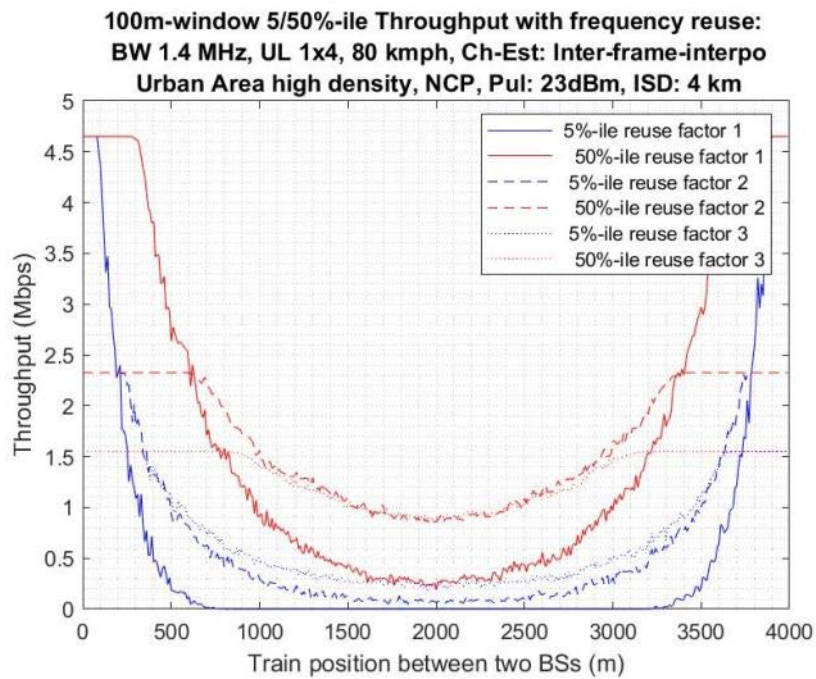

Figure B.48

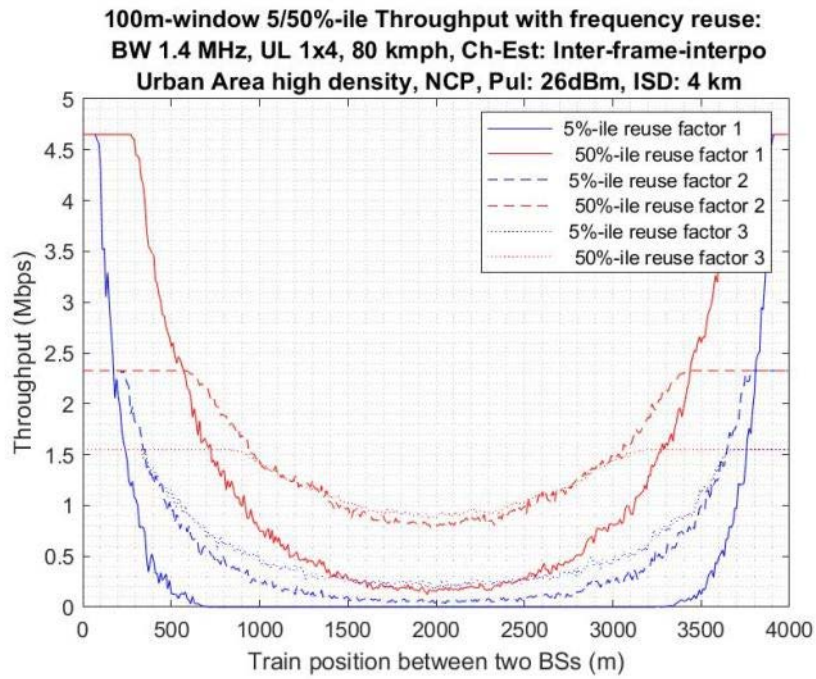

Figure B.49

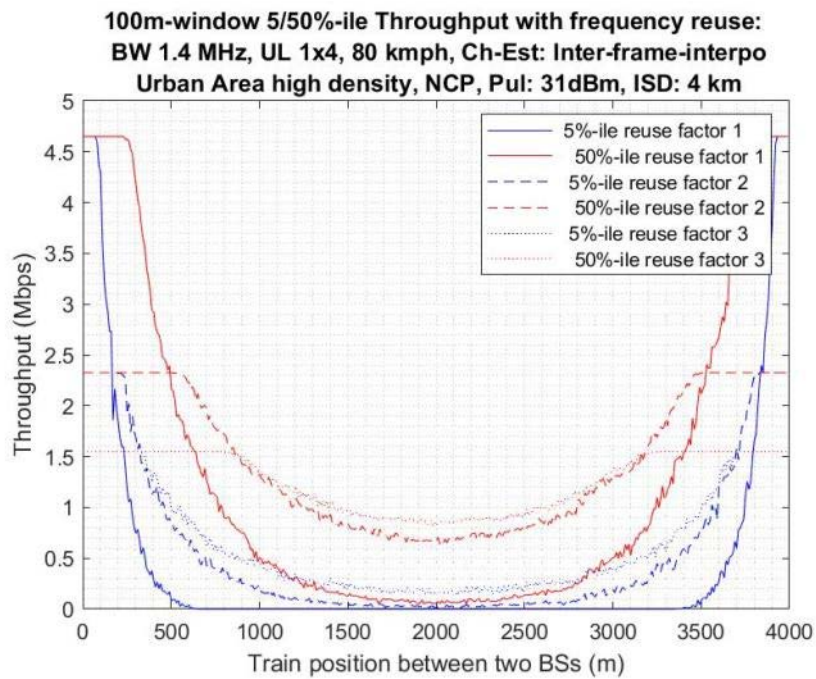

Figure B.50

Results at 3 MHz

High speed scenario

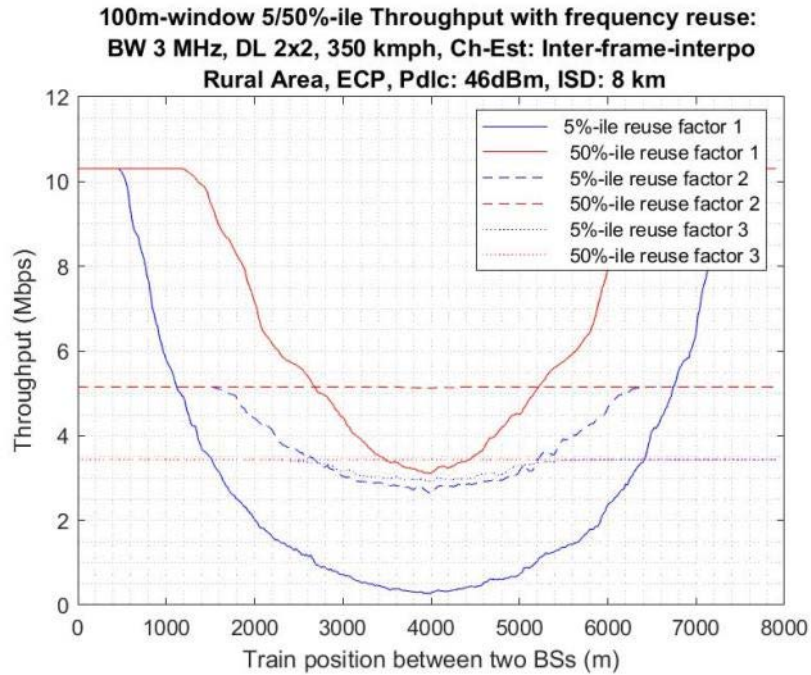

Figure B.51

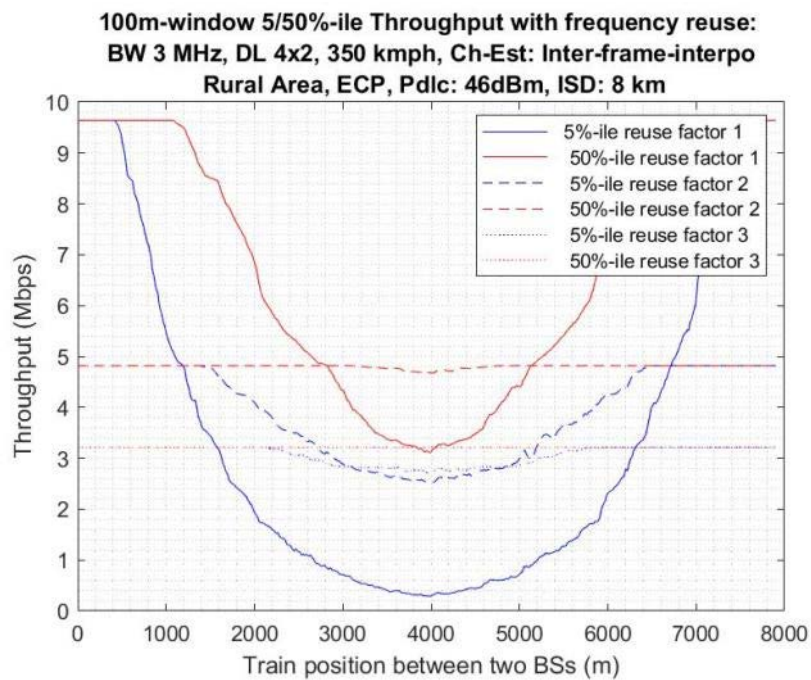

Figure B.52

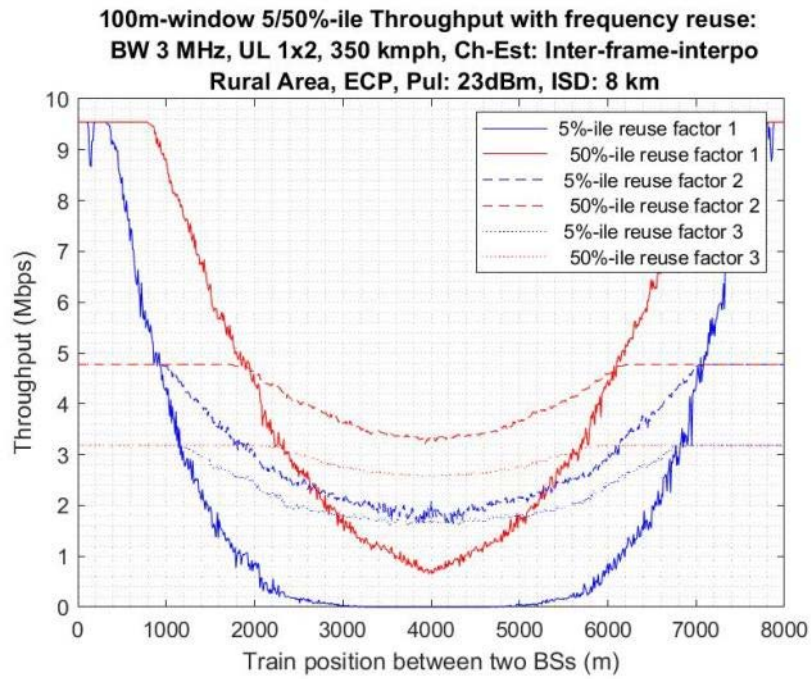

Figure B.53

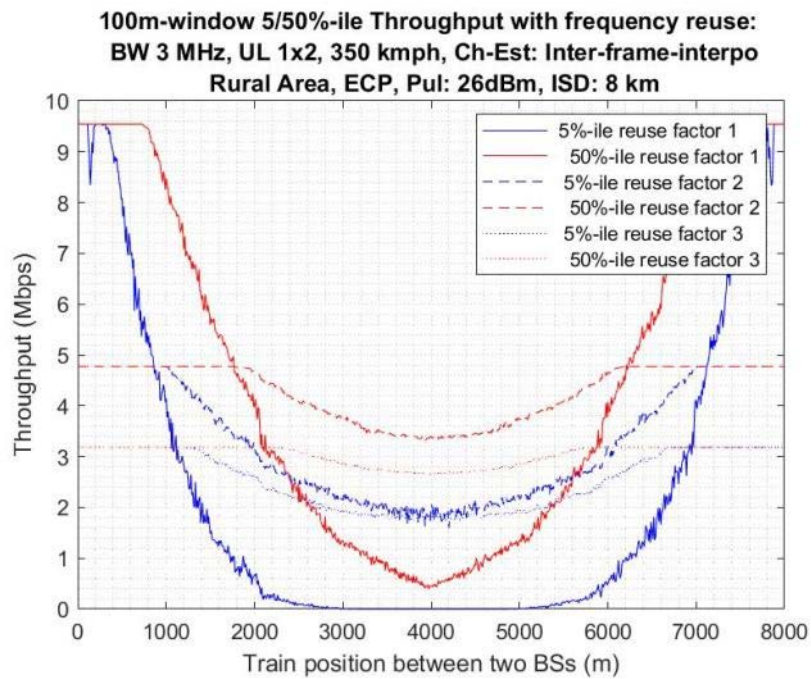

Figure B.54

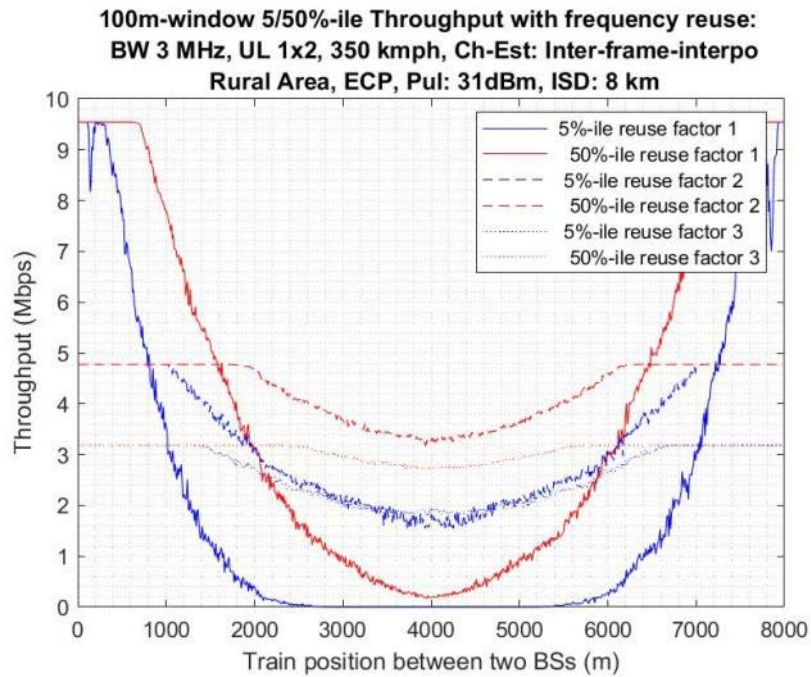

Figure B.55

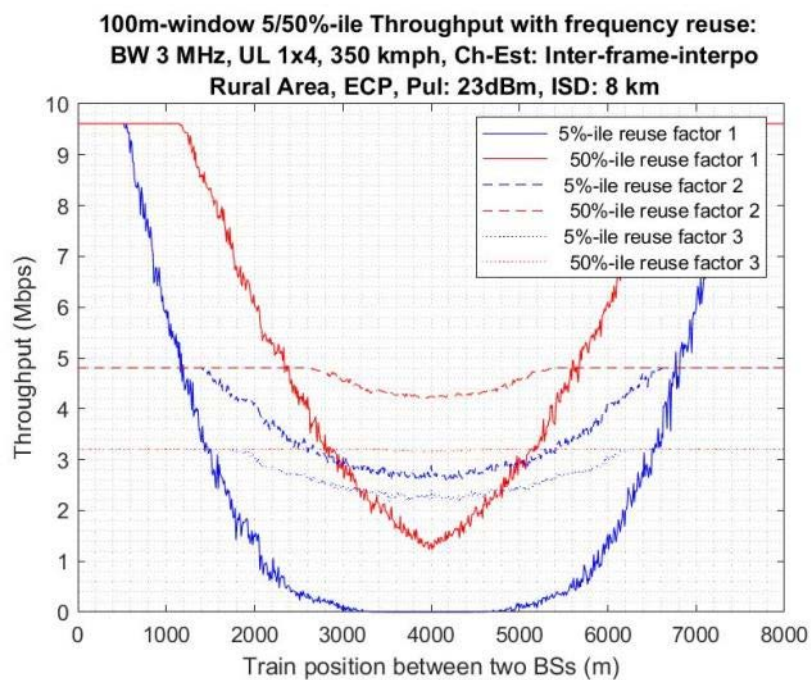

Figure B.56

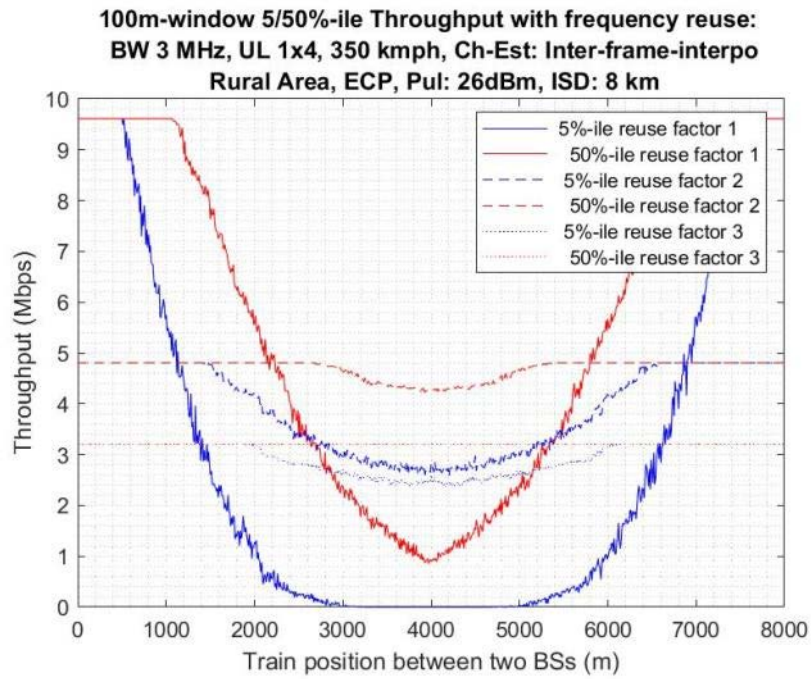

Figure B.57

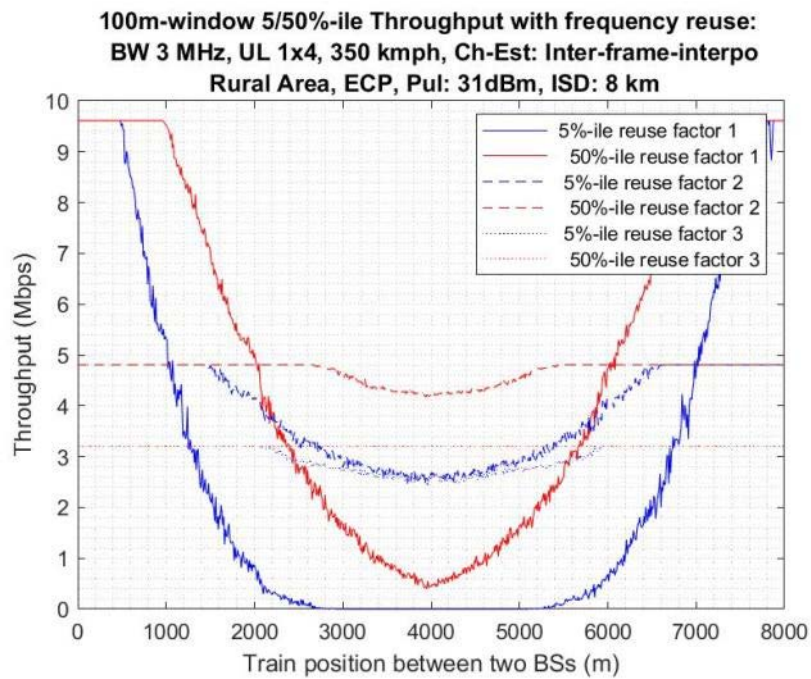

Figure B.58

Hilly scenario

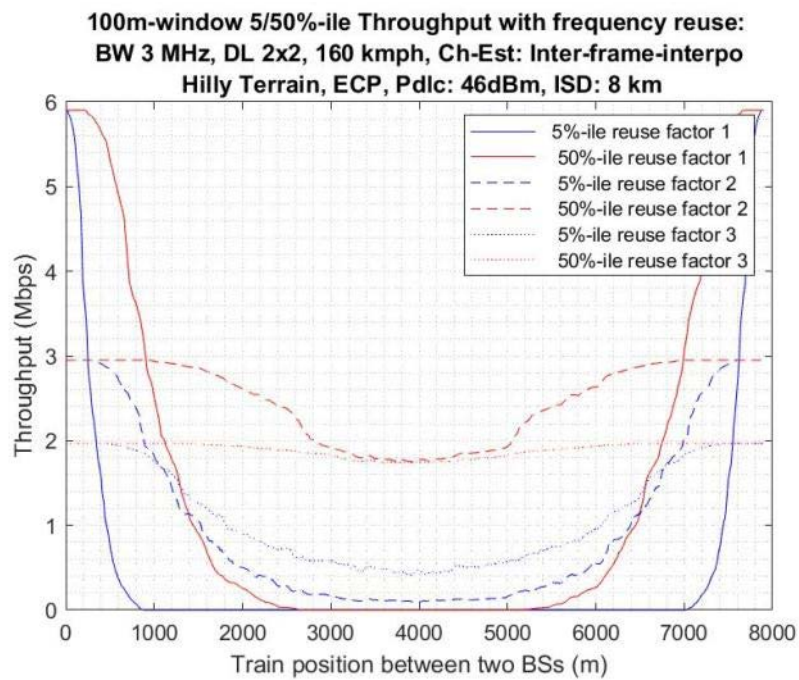

Figure B.59

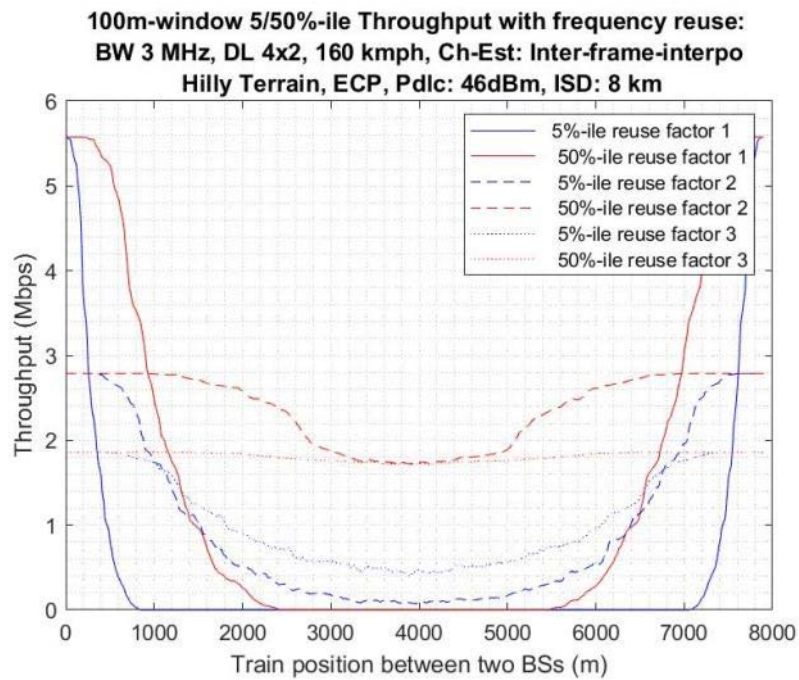

Figure B.60

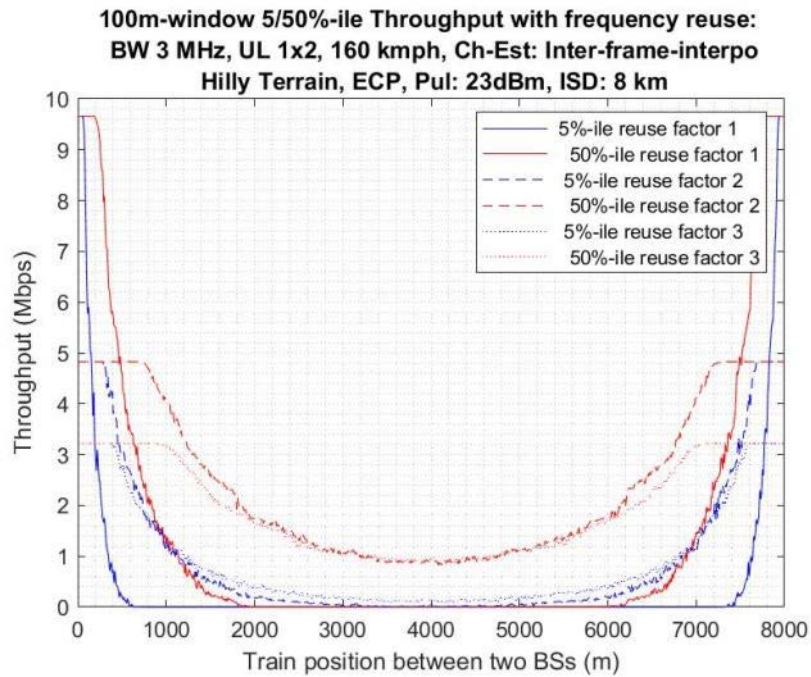

Figure B.61

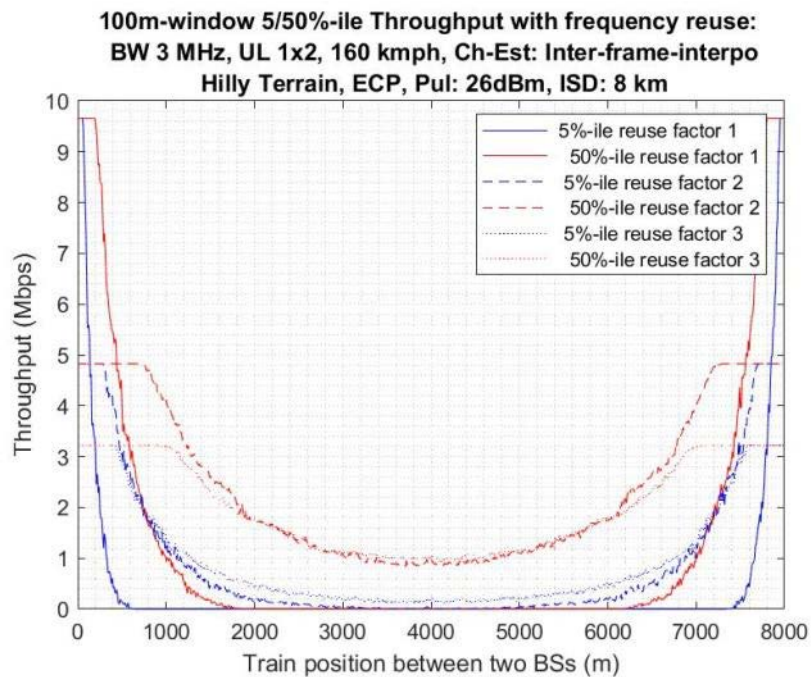

Figure B.62

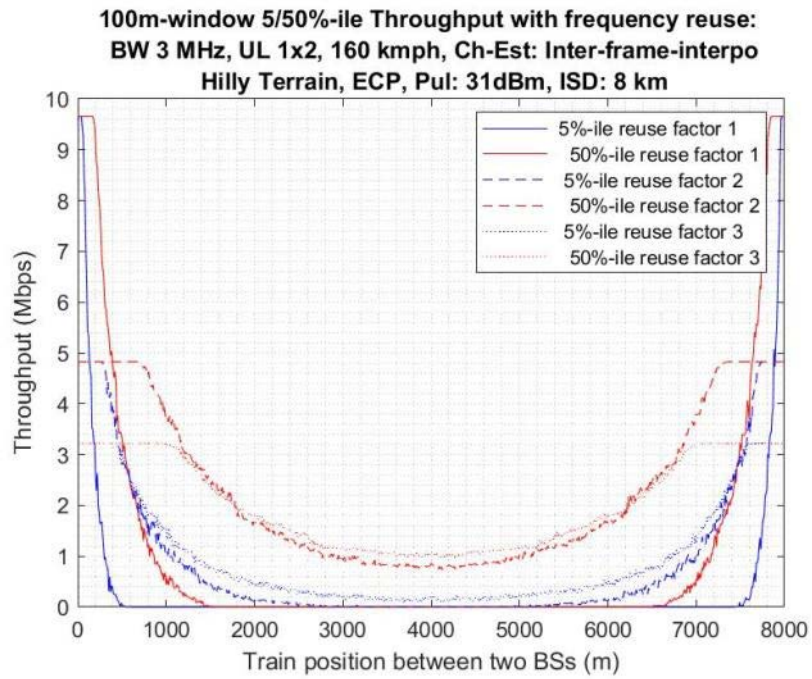

Figure B.63

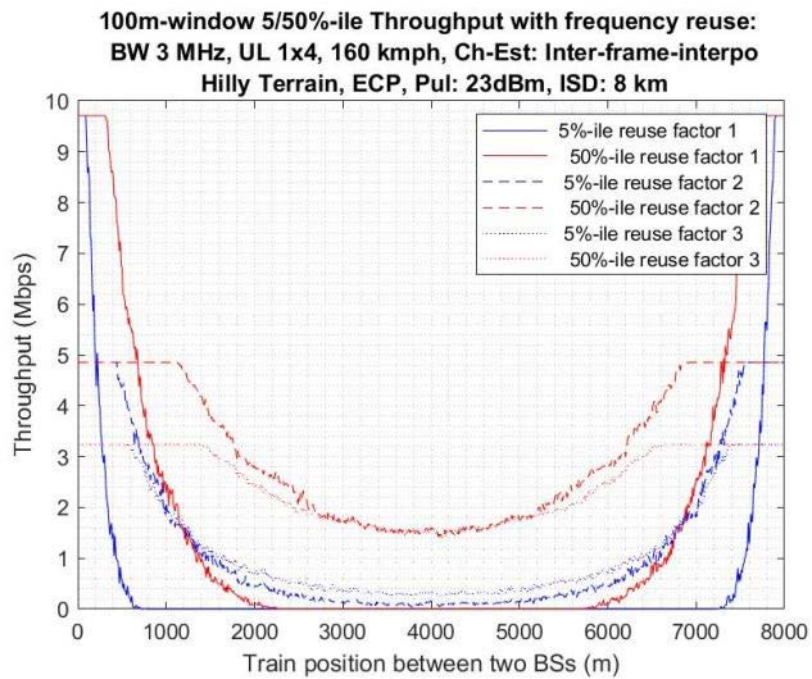

Figure B.64

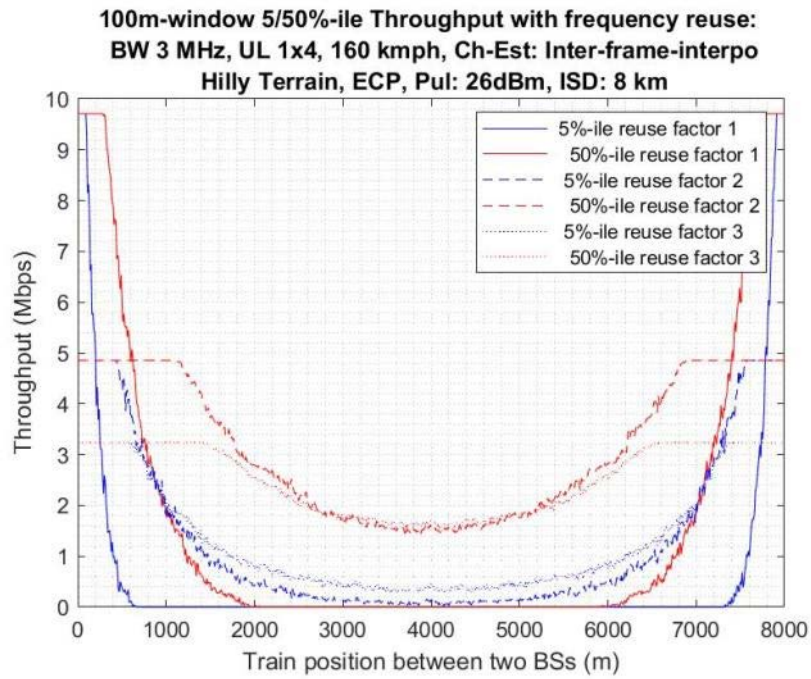

Figure B.65

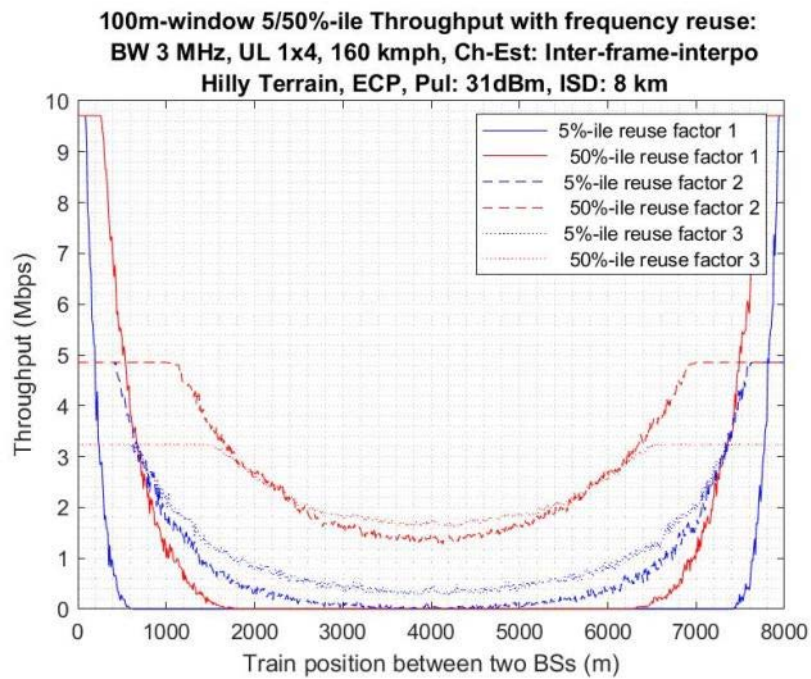

Figure B.66

Urban scenario

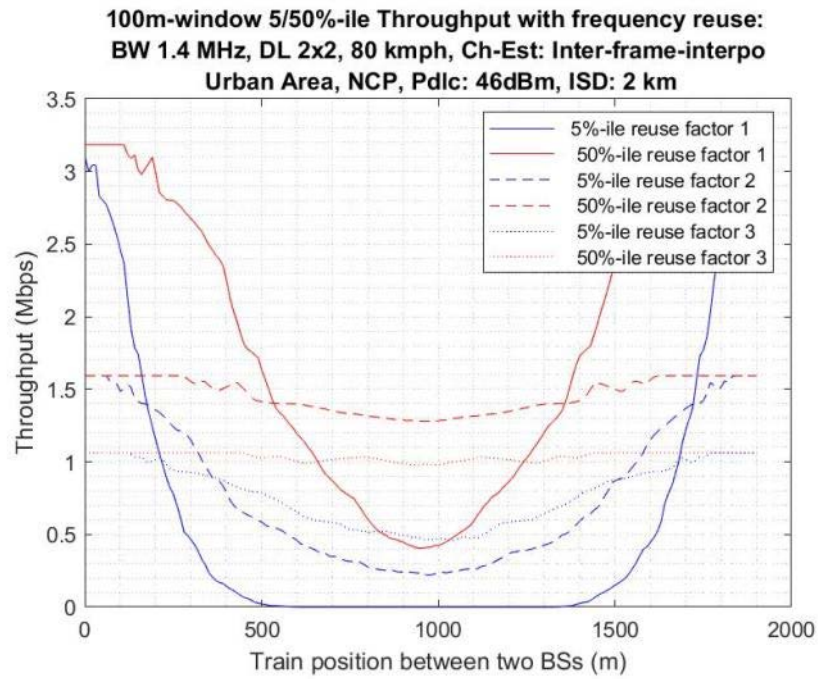

Figure B.67

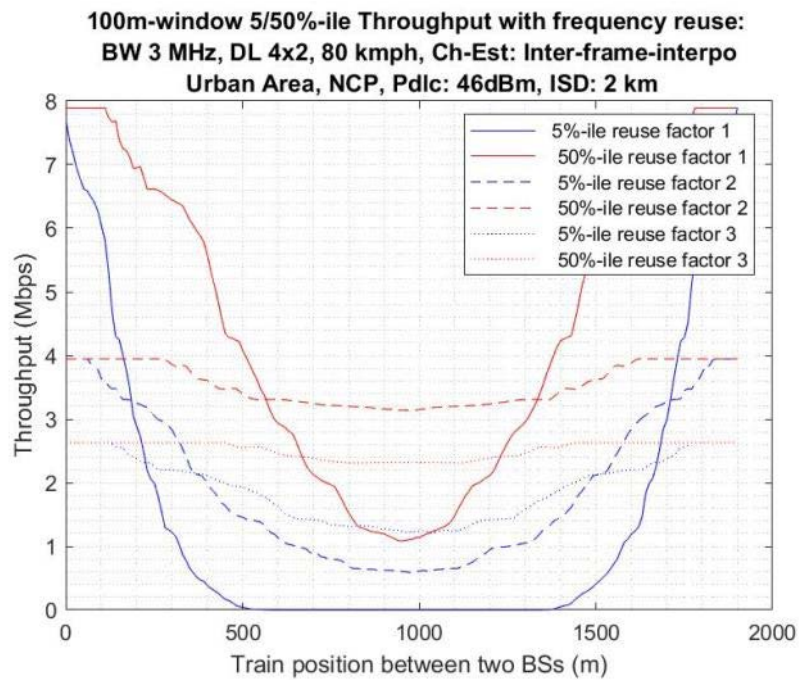

Figure B.68

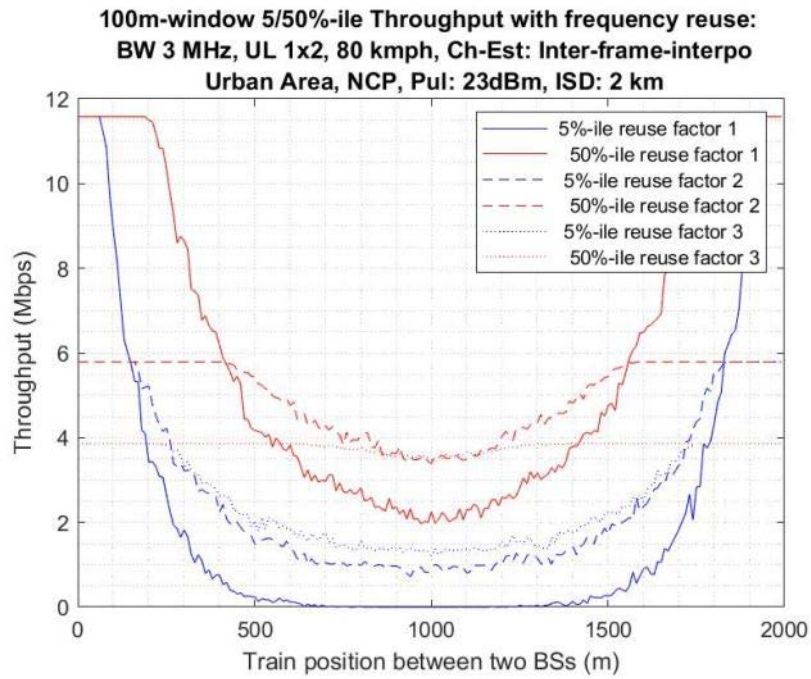

Figure B.69

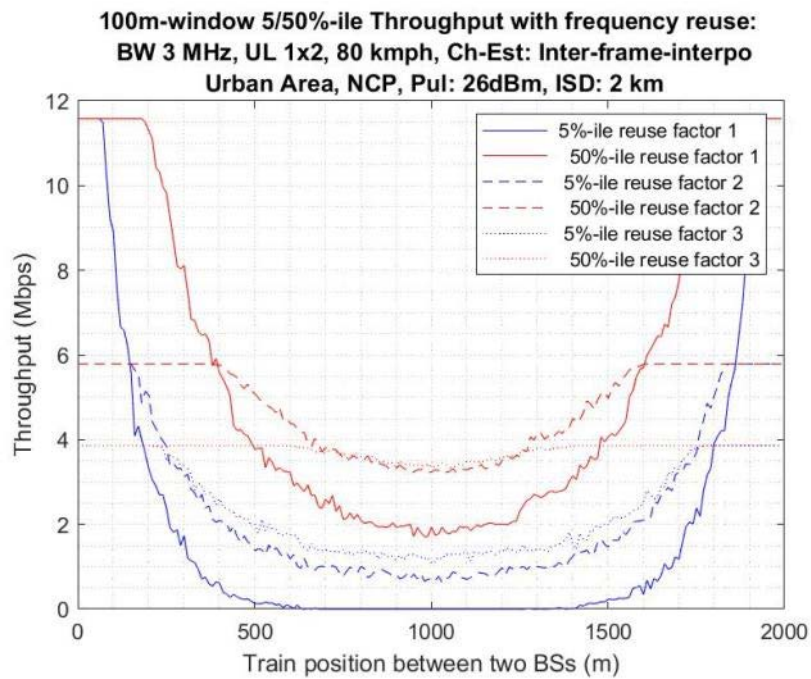

Figure B.70

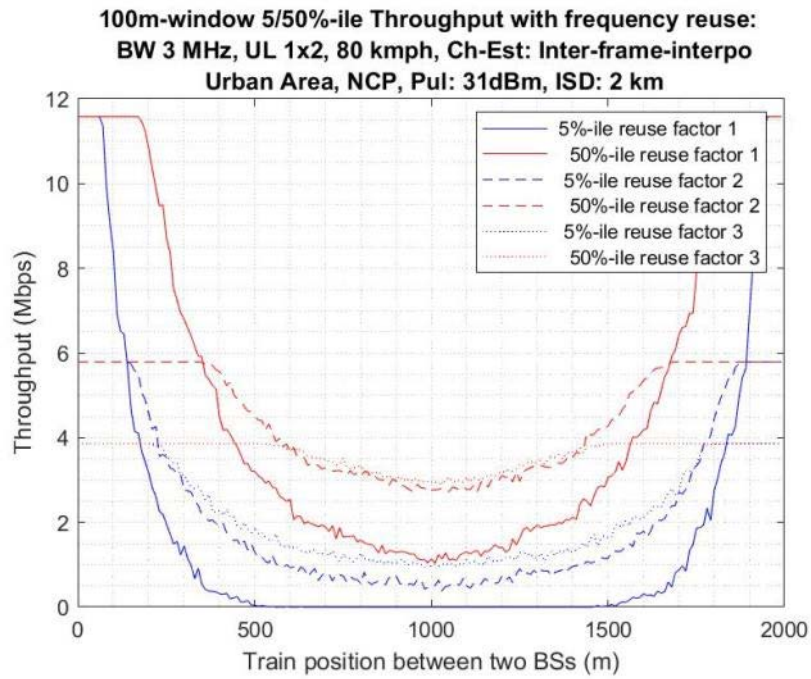

Figure B.71

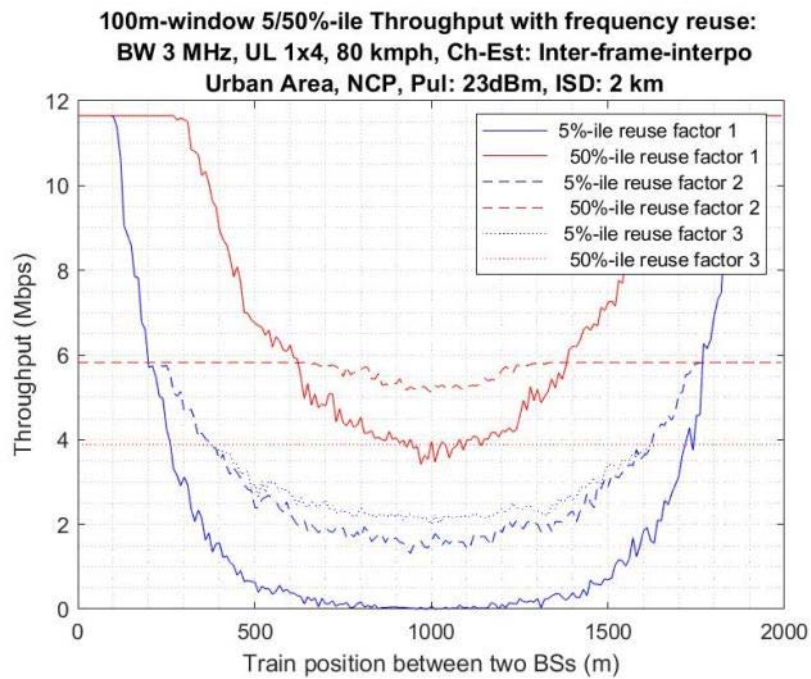

Figure B.72

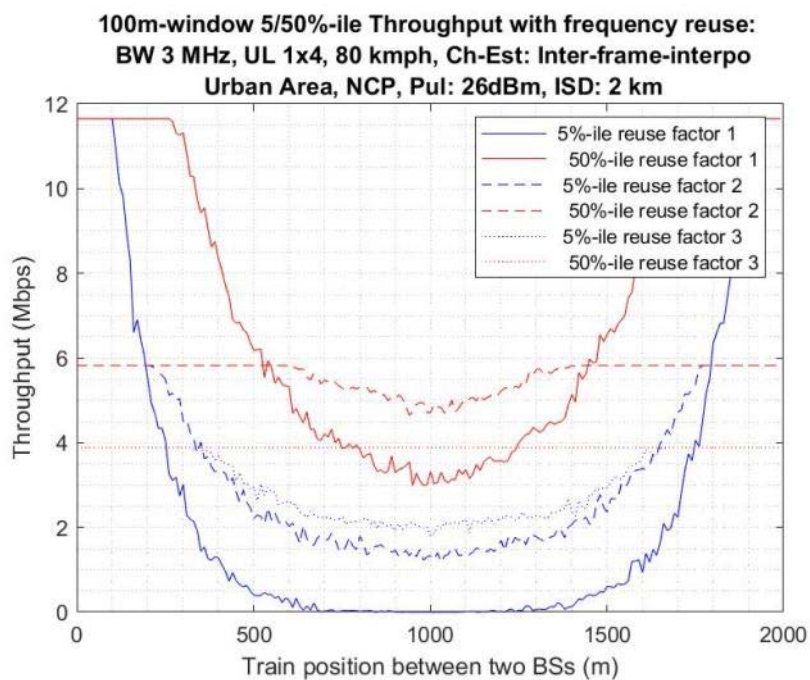

Figure B.73

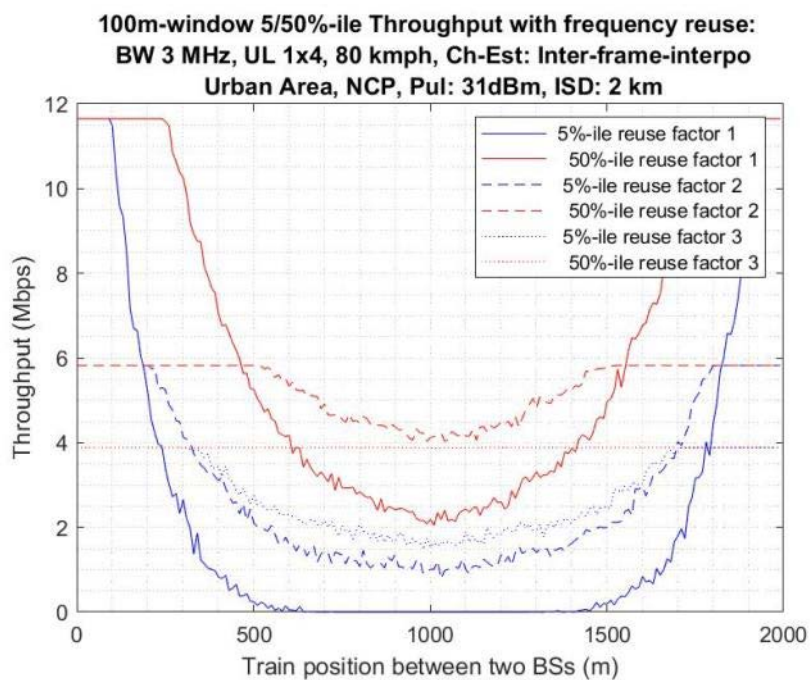

Figure B.74

High density scenario

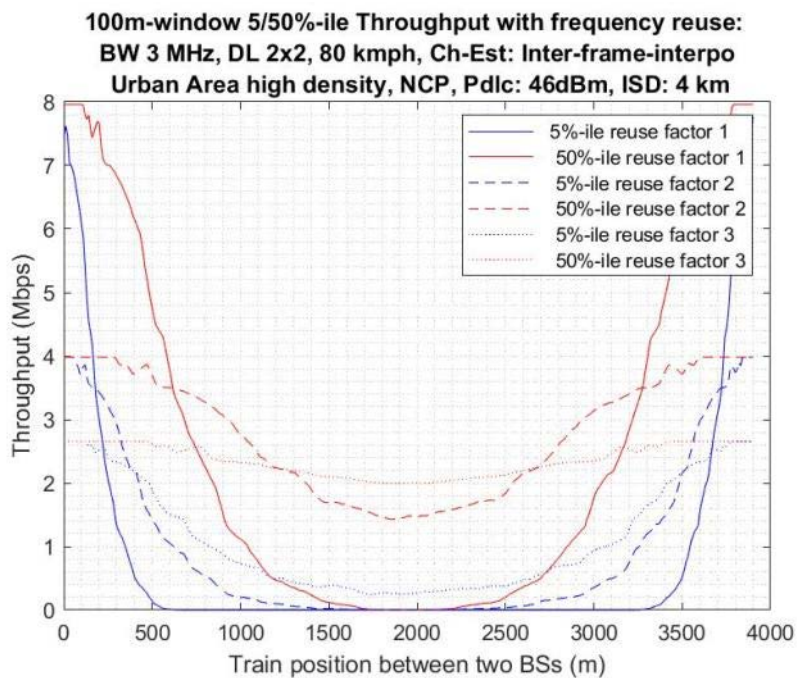

Figure B.75

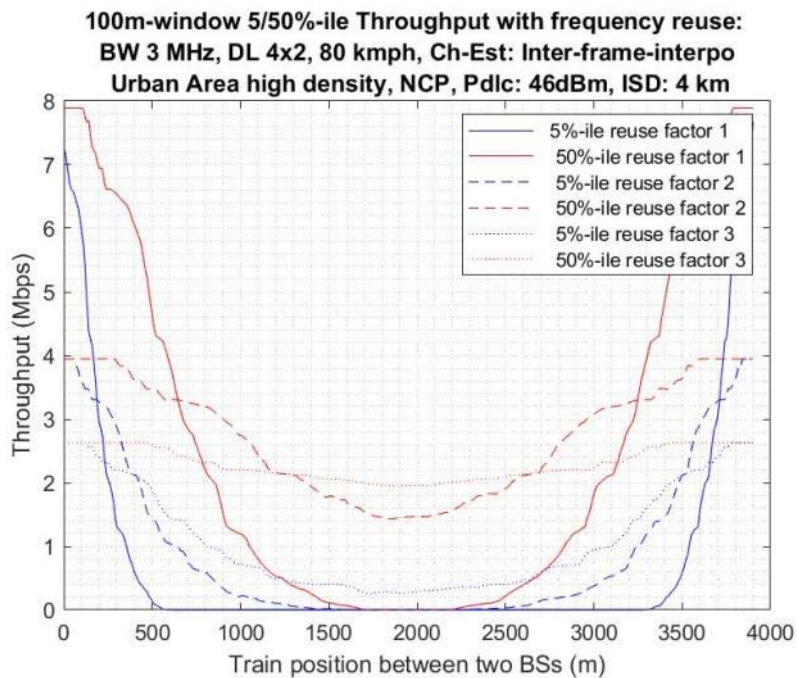

Figure B.76

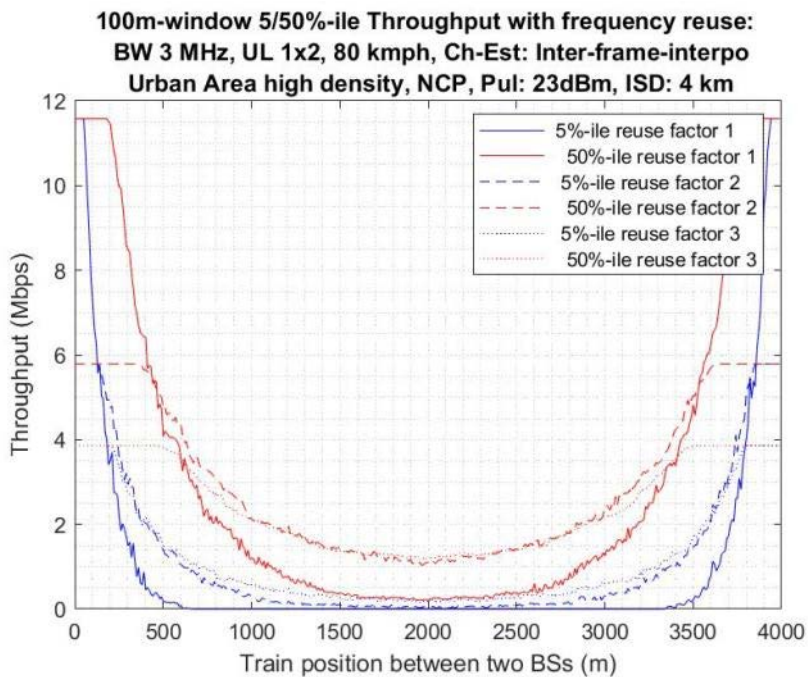

Figure B.77

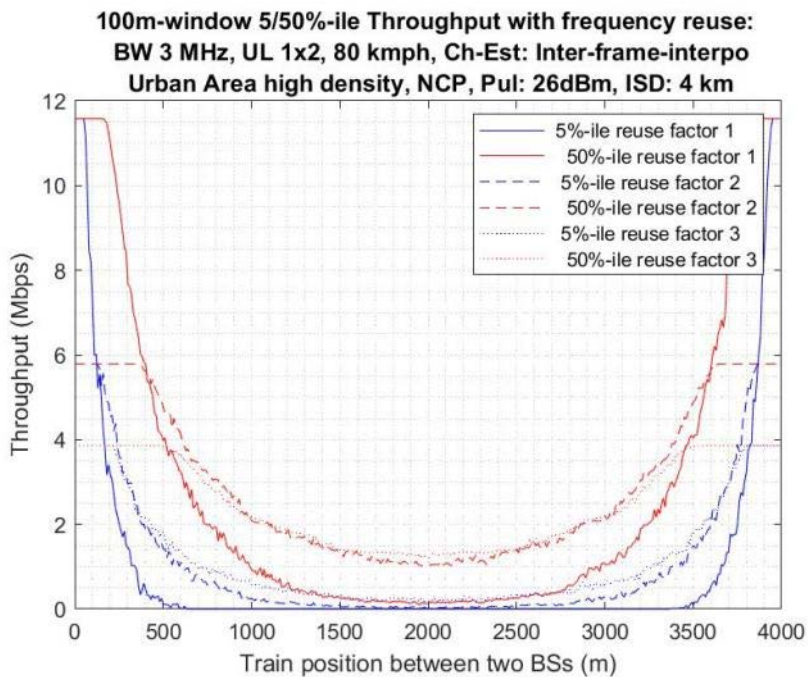

Figure B.78

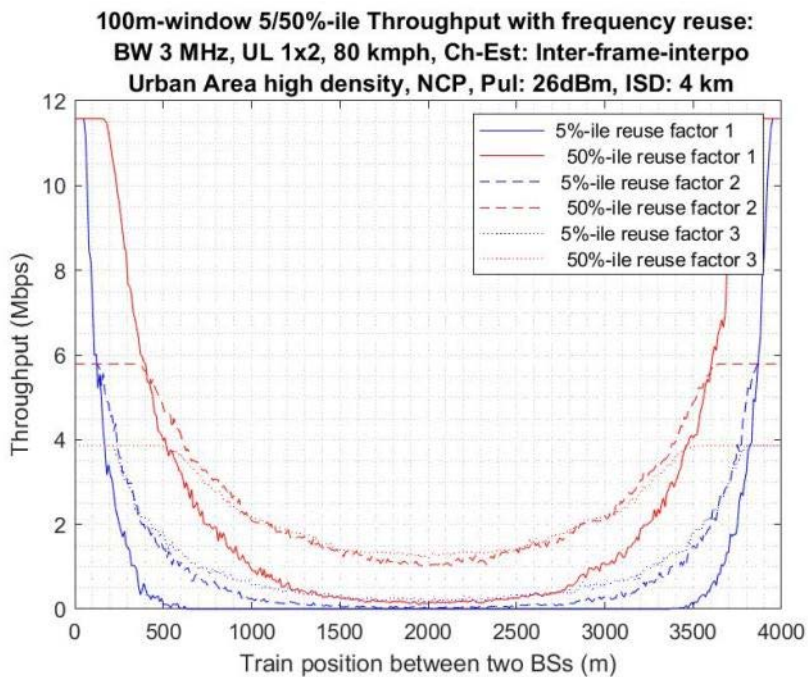

Figure B.79

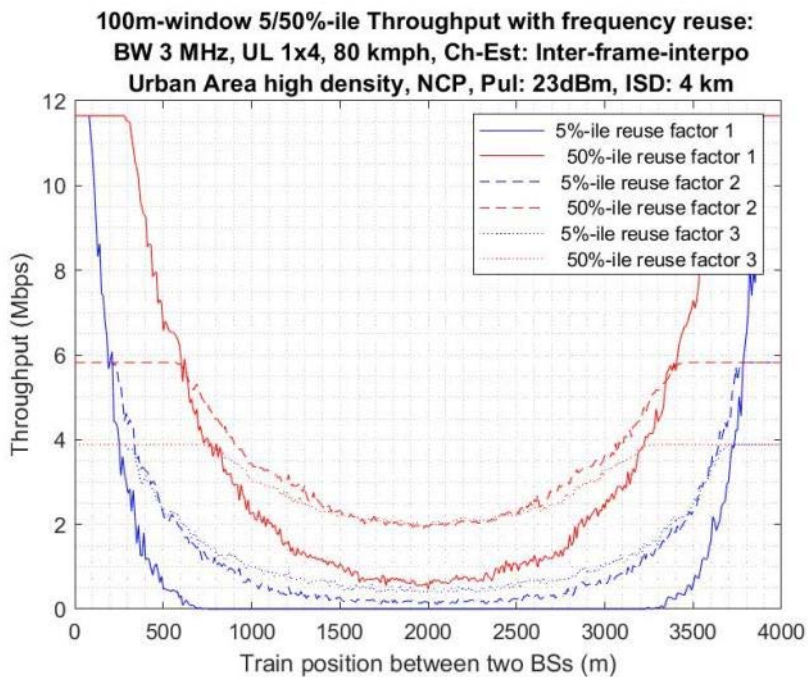

Figure B.80

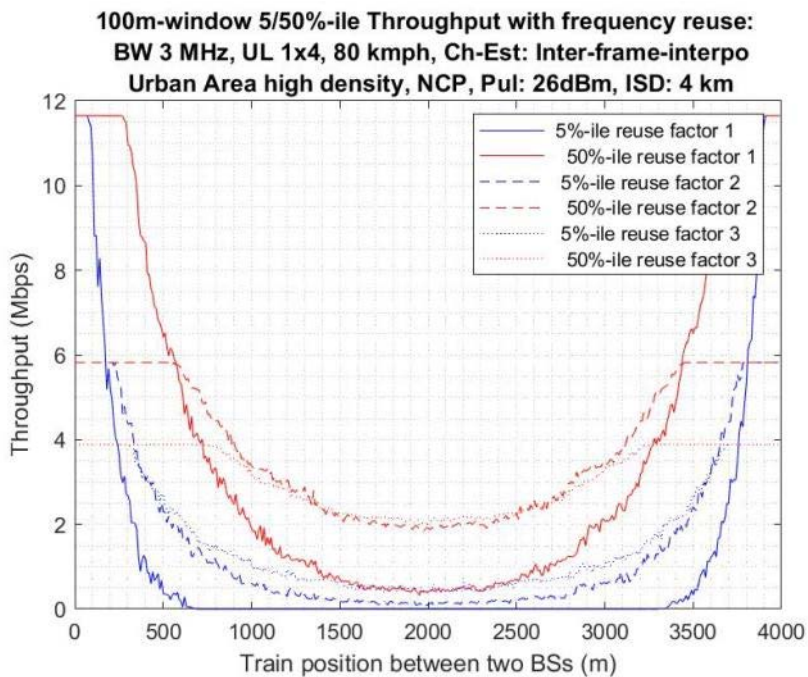

Figure B.81

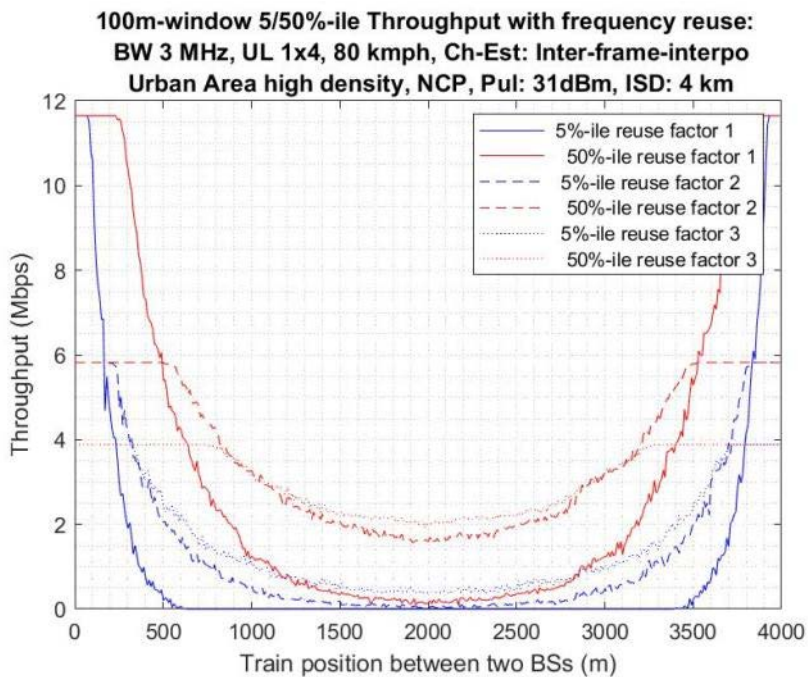

Figure B.82

Results at 5 MHz

High speed scenario

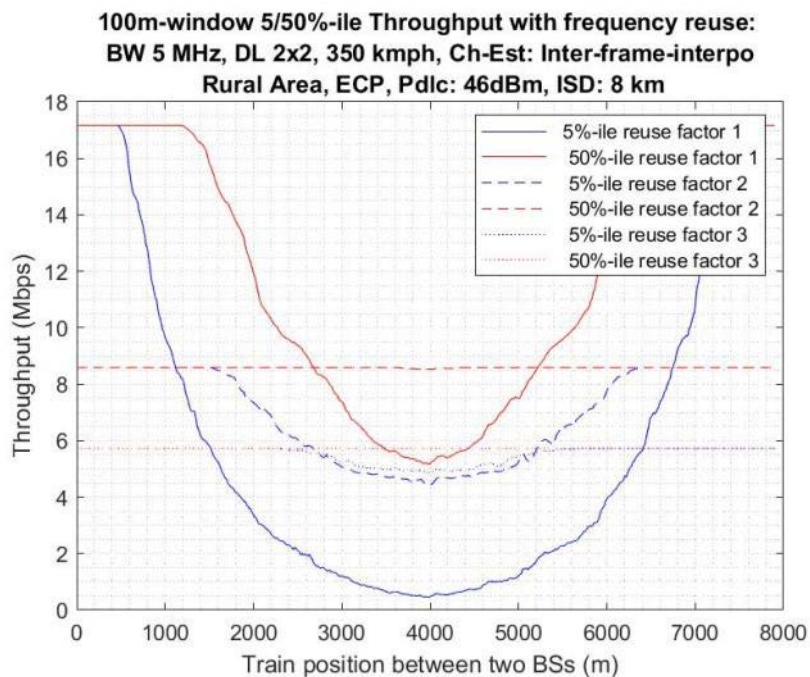

Figure B.83

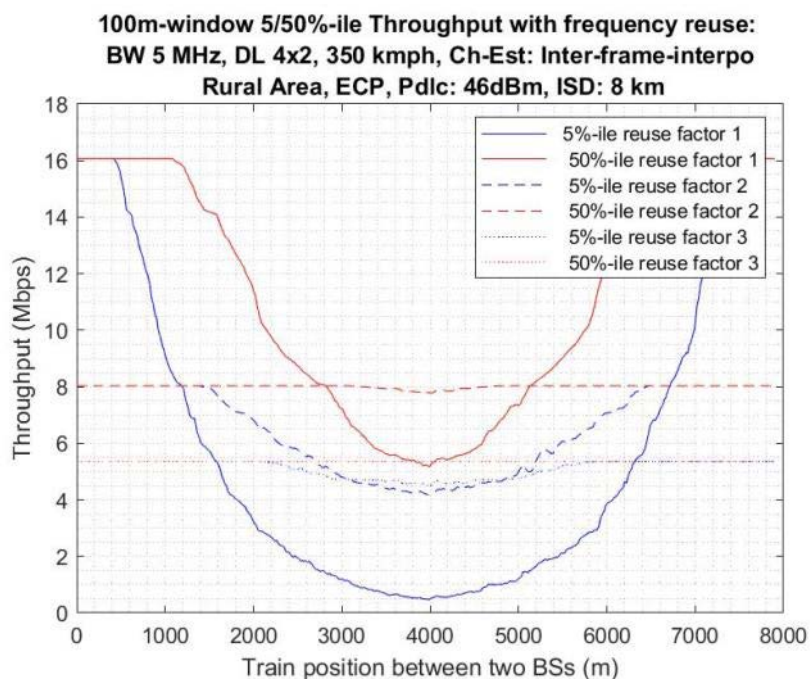

Figure B.84

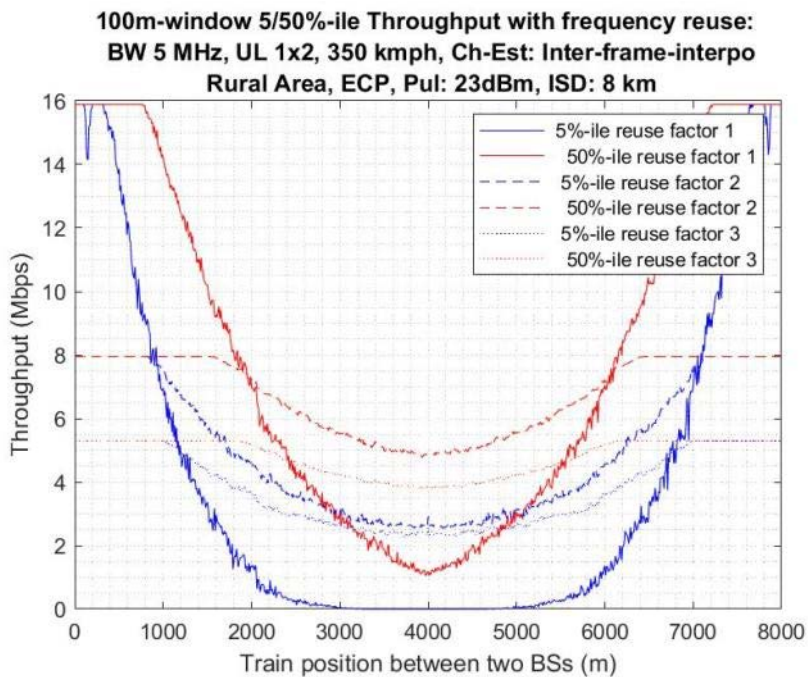

Figure B.85

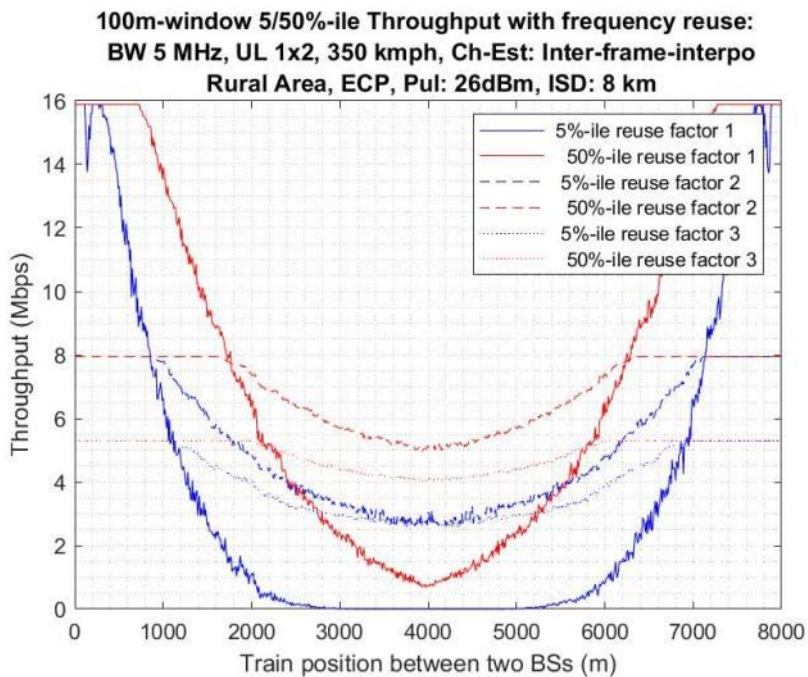

Figure B.86

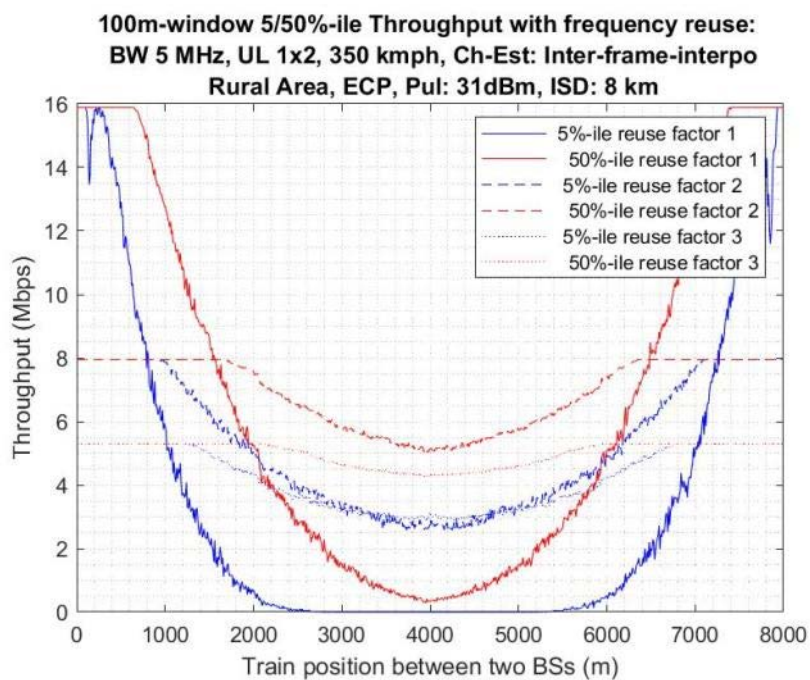

Figure B.87

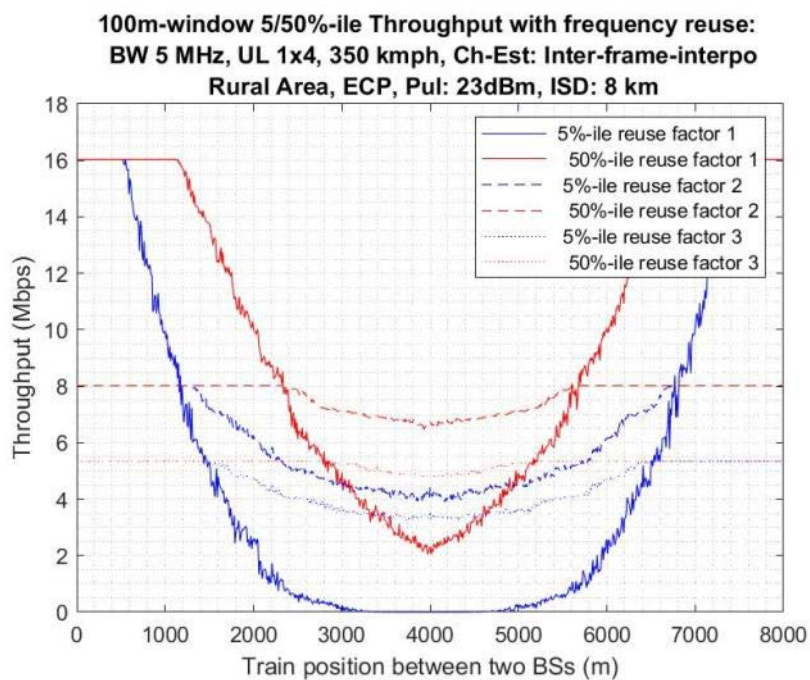

Figure B.88

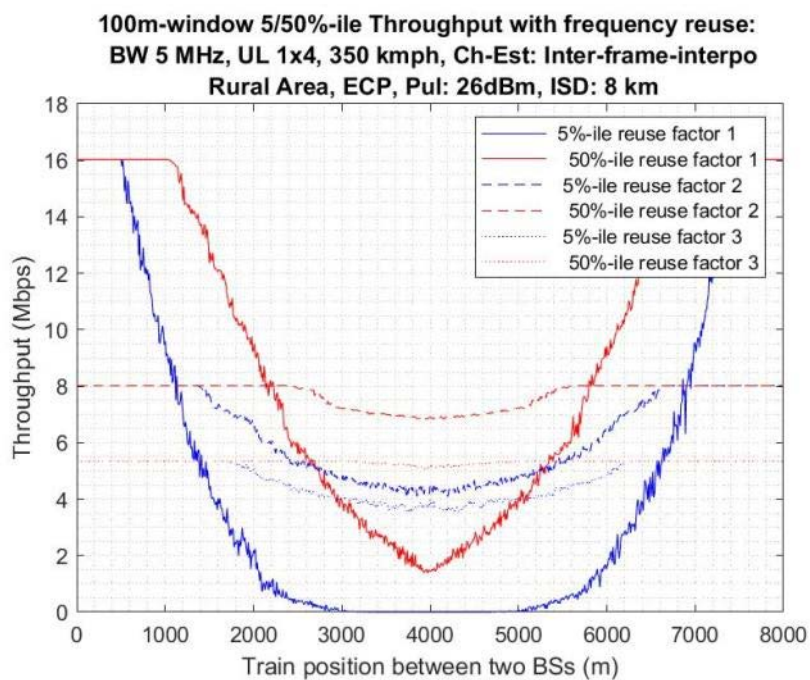

Figure B.89

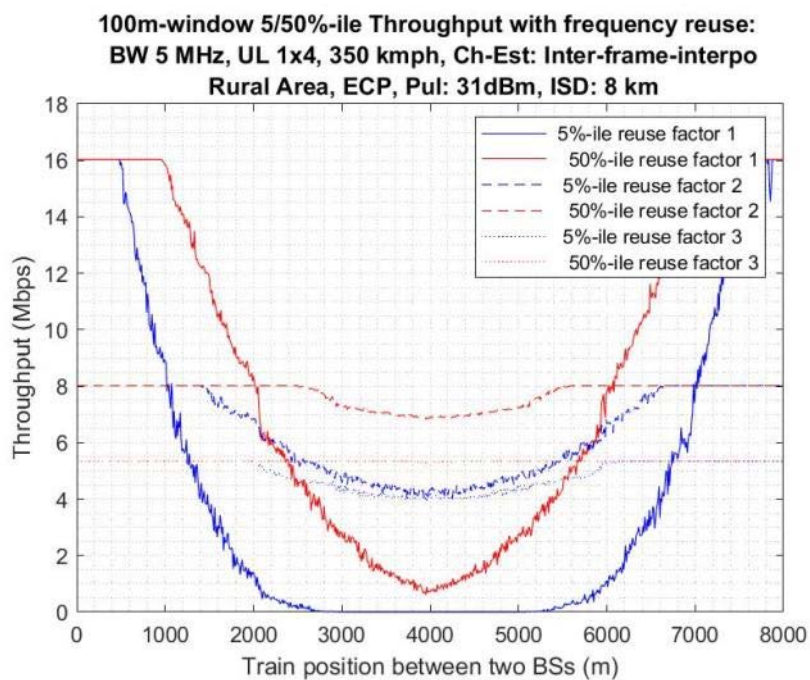

Figure B.90

Hilly scenario

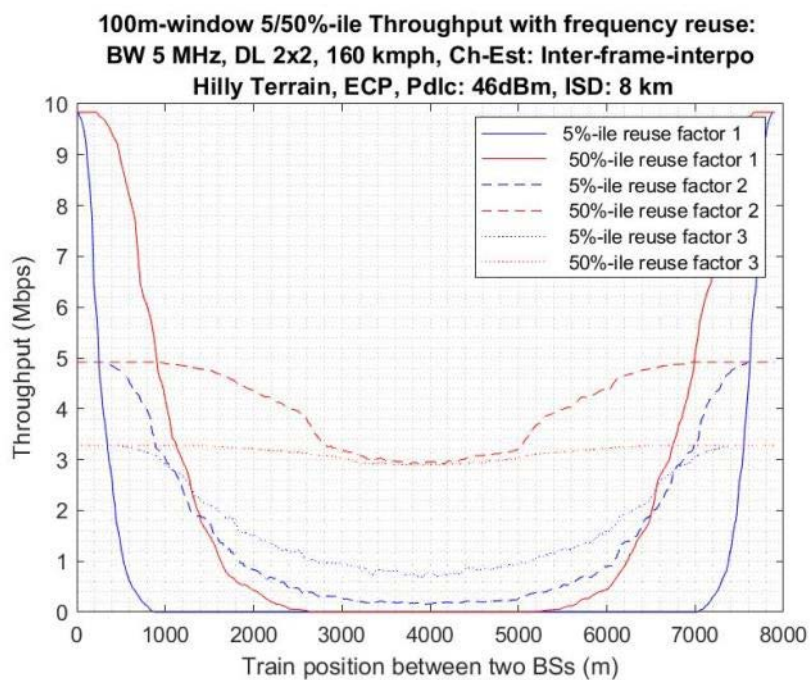

Figure B.91

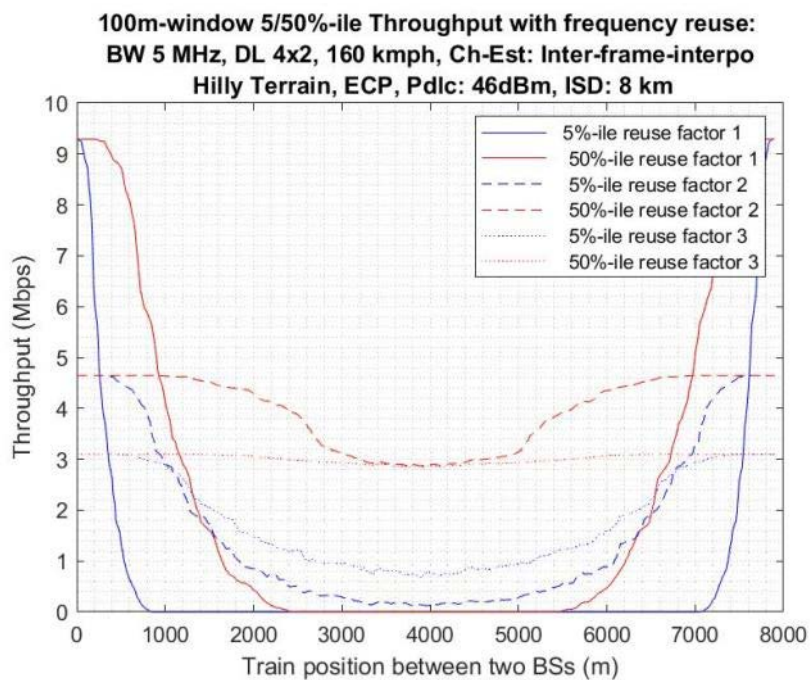

Figure B.92

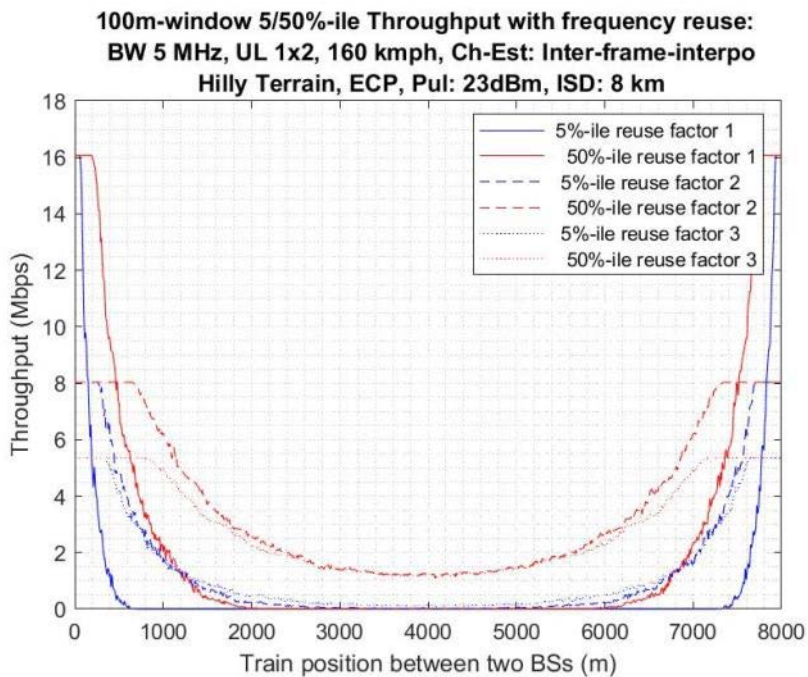

Figure B.93

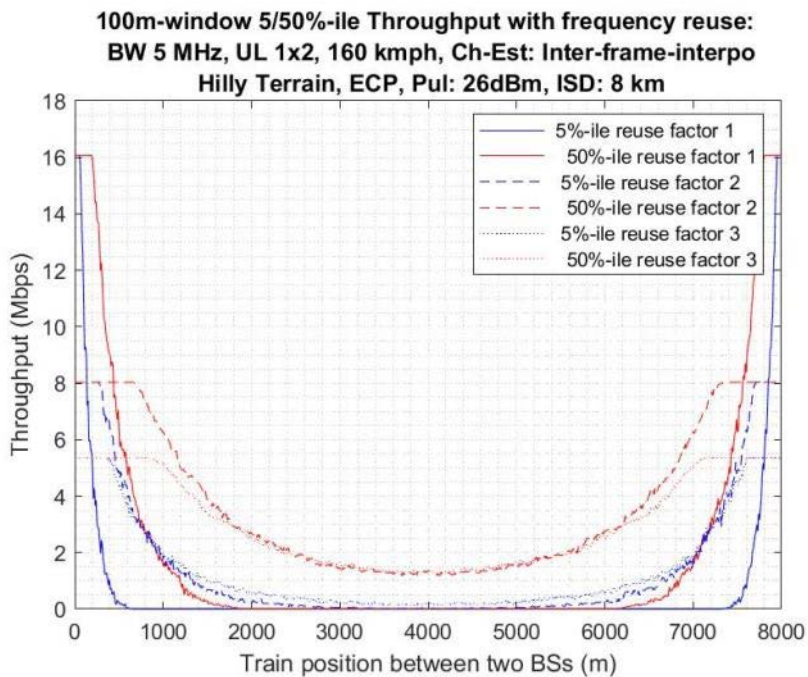

Figure B.94

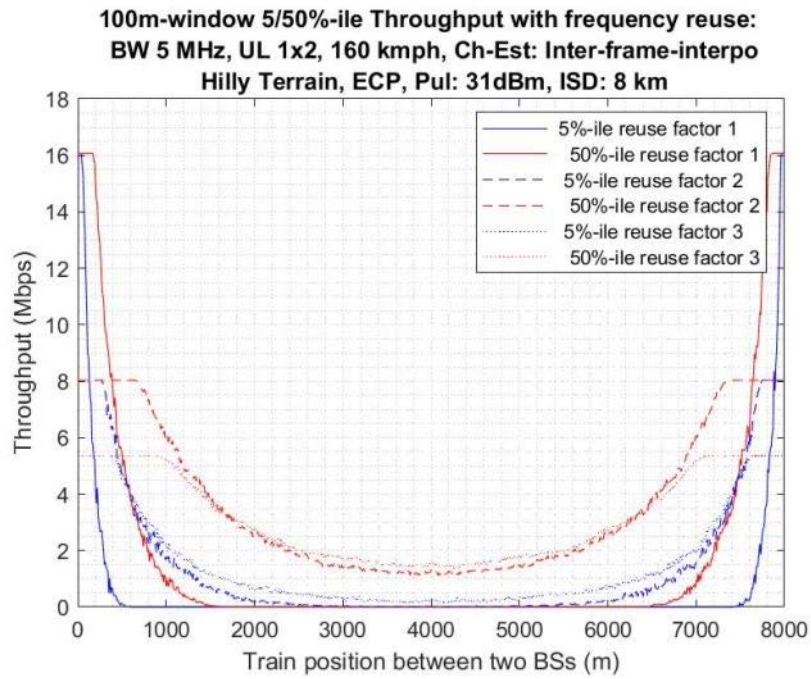

Figure B.95

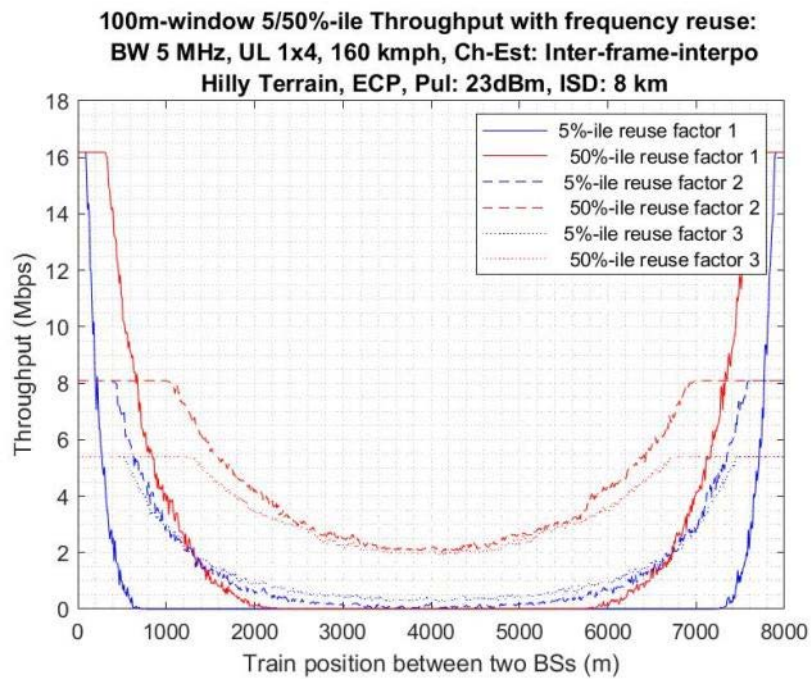

Figure B.96

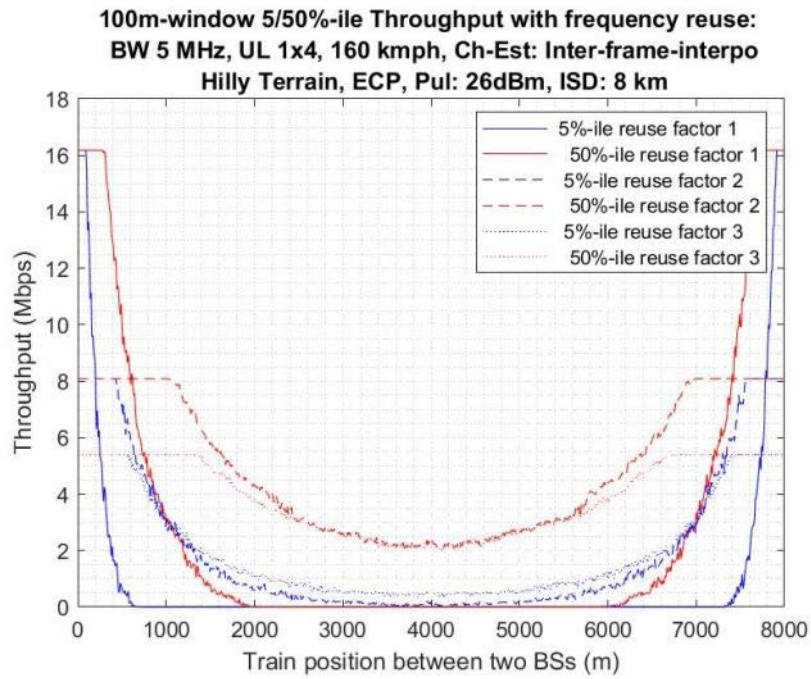

Figure B.97

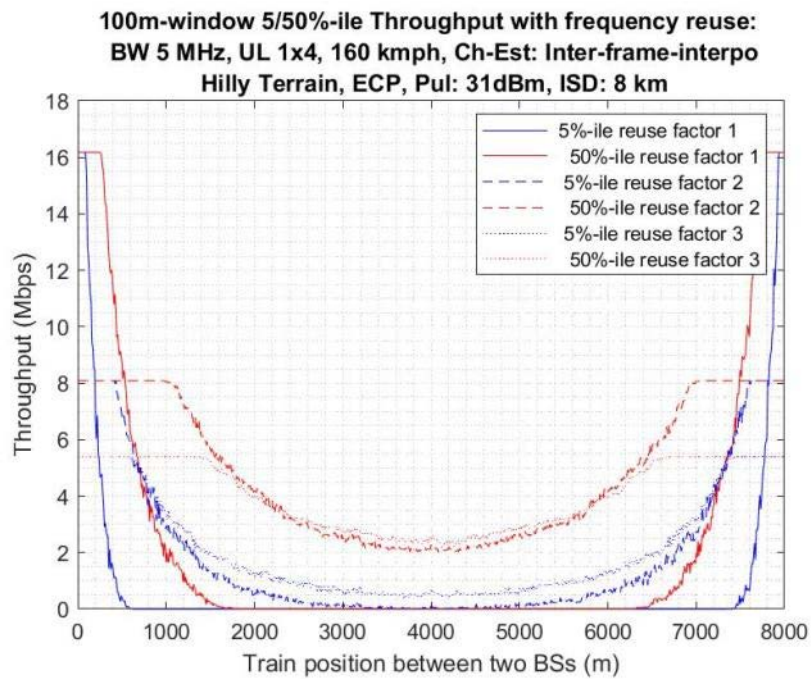

Figure B.98

Urban scenario

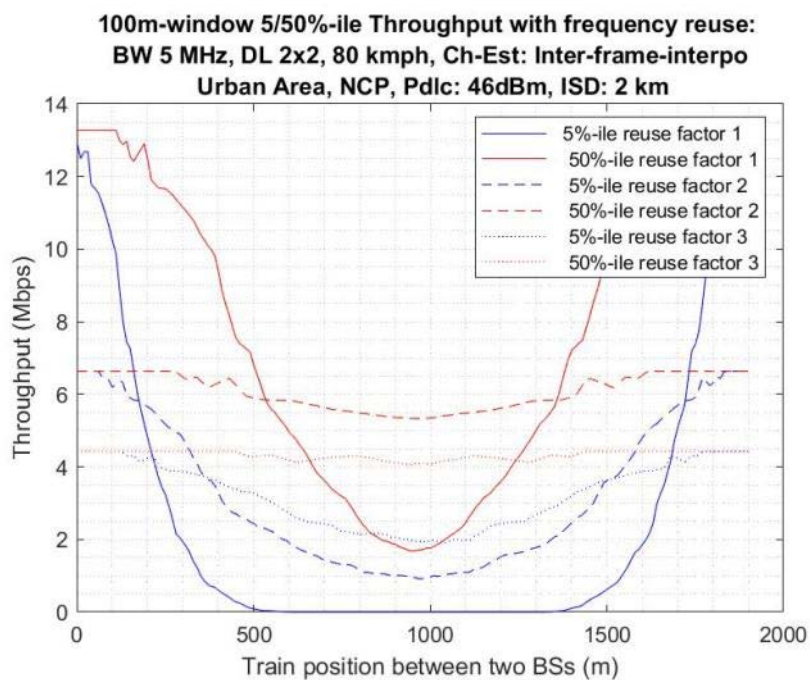

Figure B.99

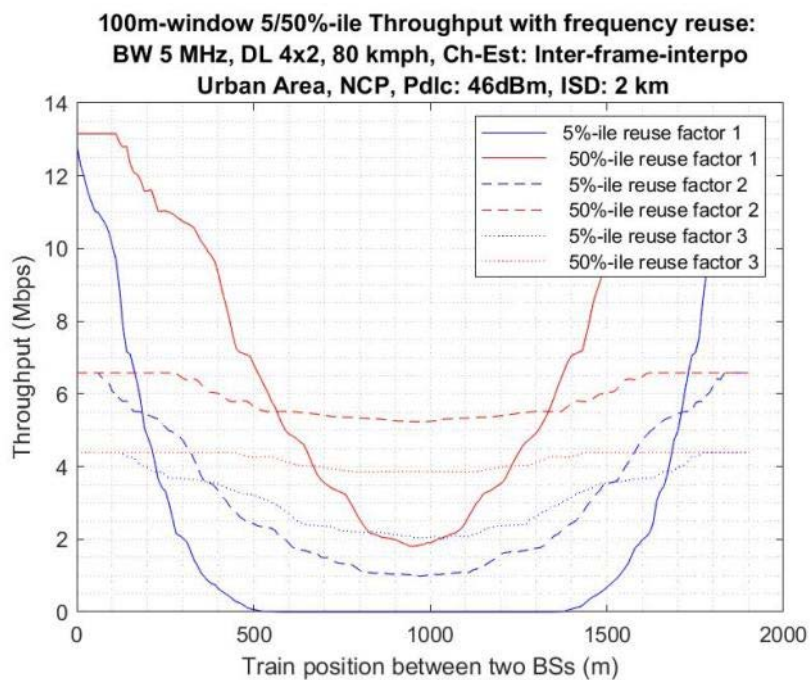

Figure B.100

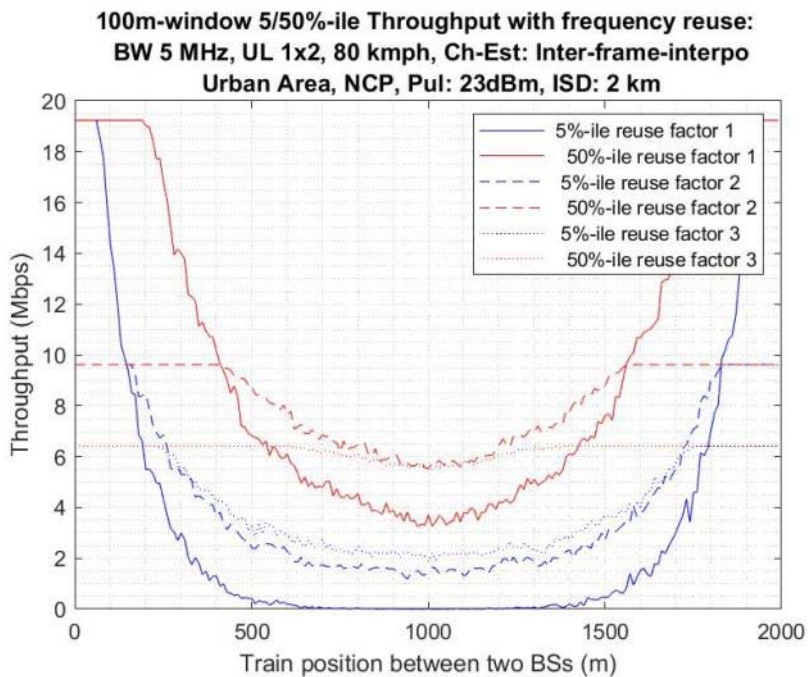

Figure B.101

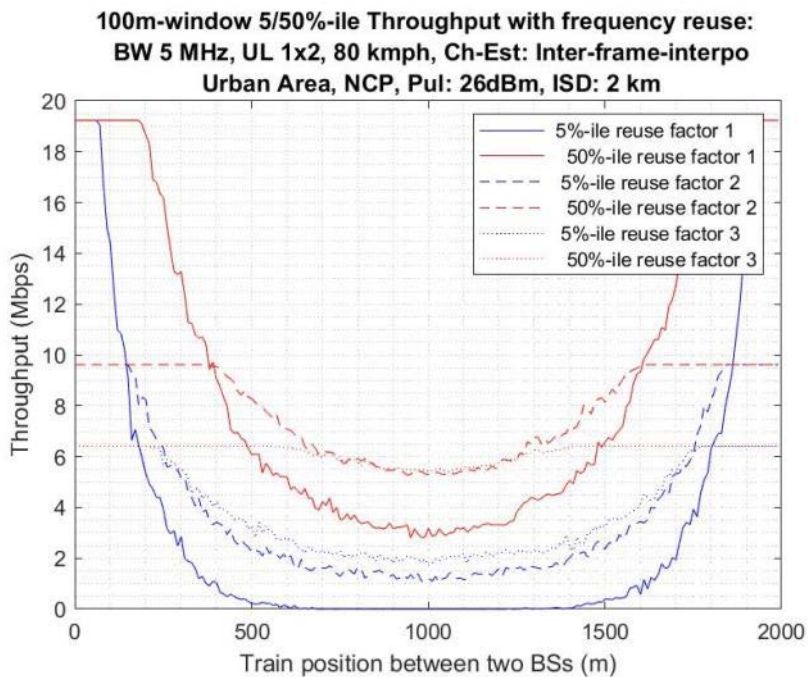

Figure B.102

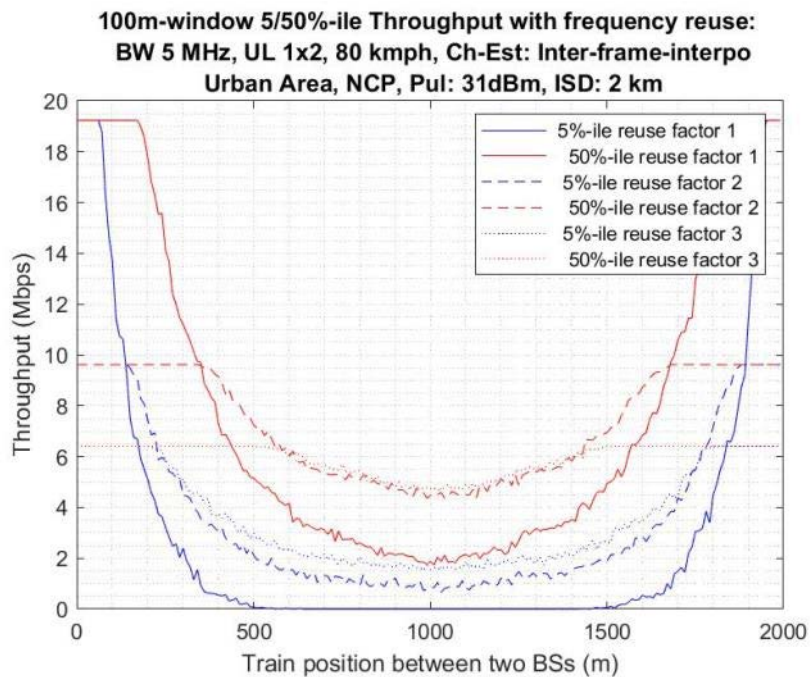

Figure B.103

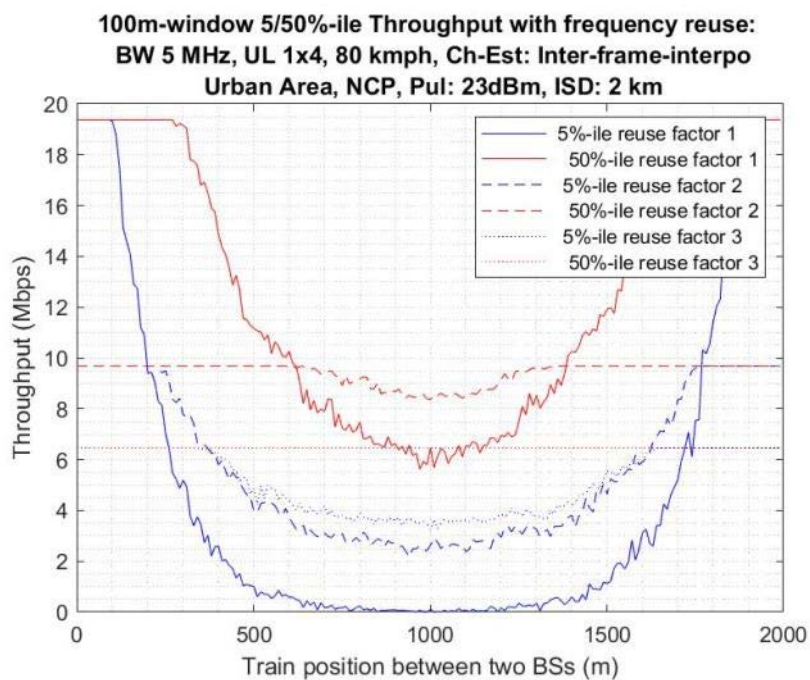

Figure B.104

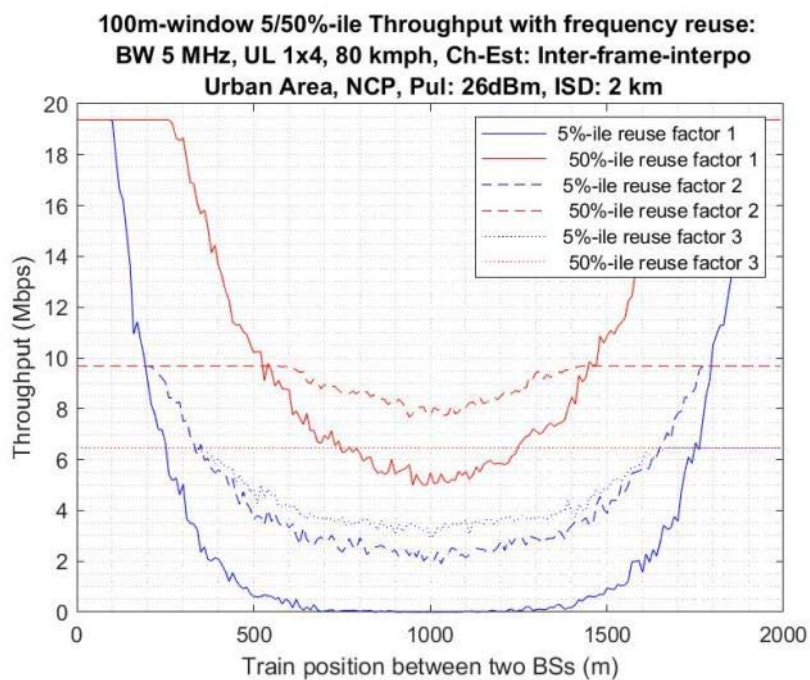

Figure B.105

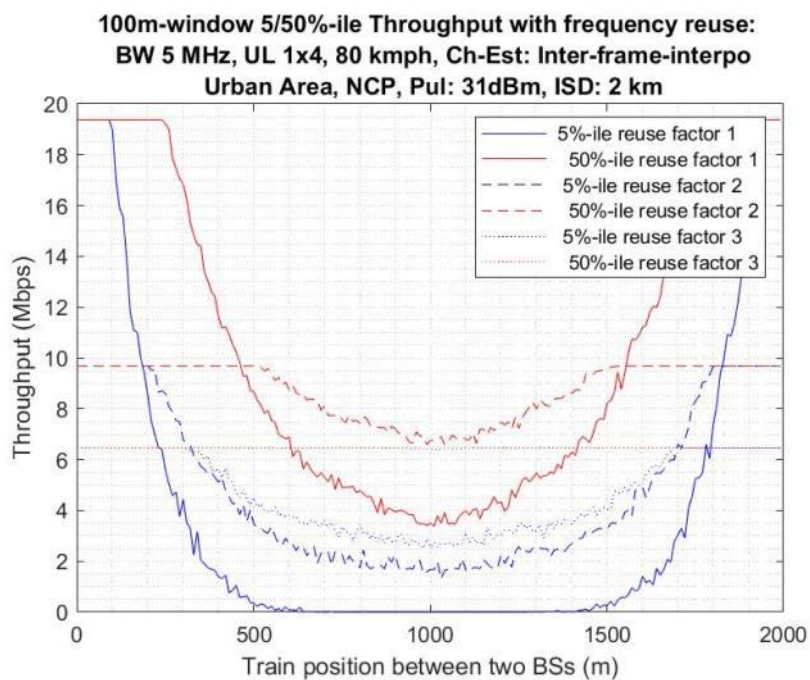

Figure B.106

High density scenario

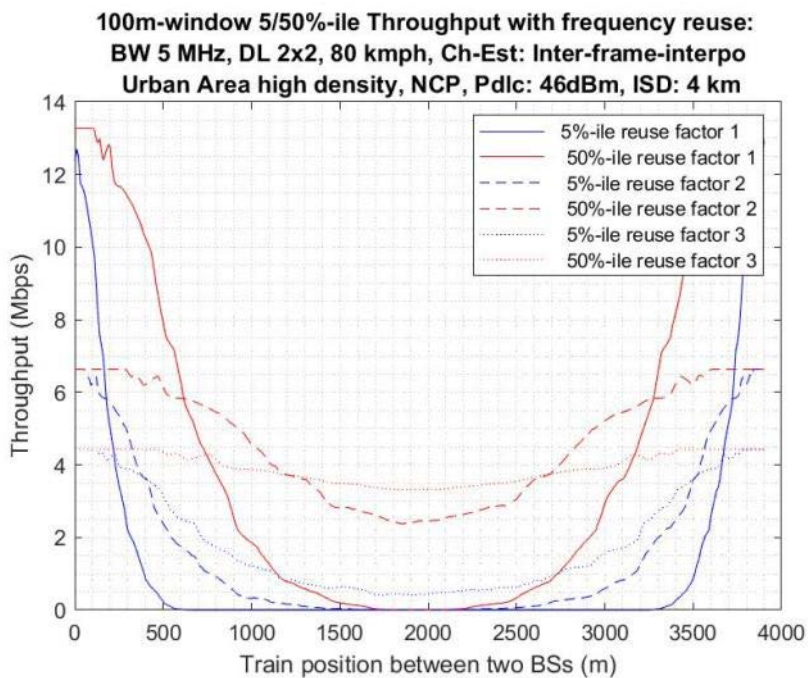

Figure B.107

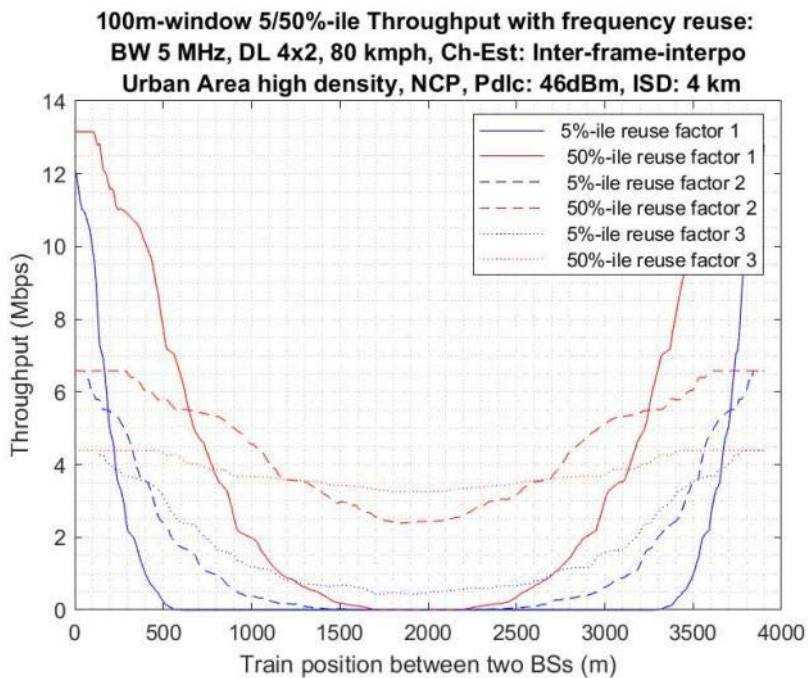

Figure B.108

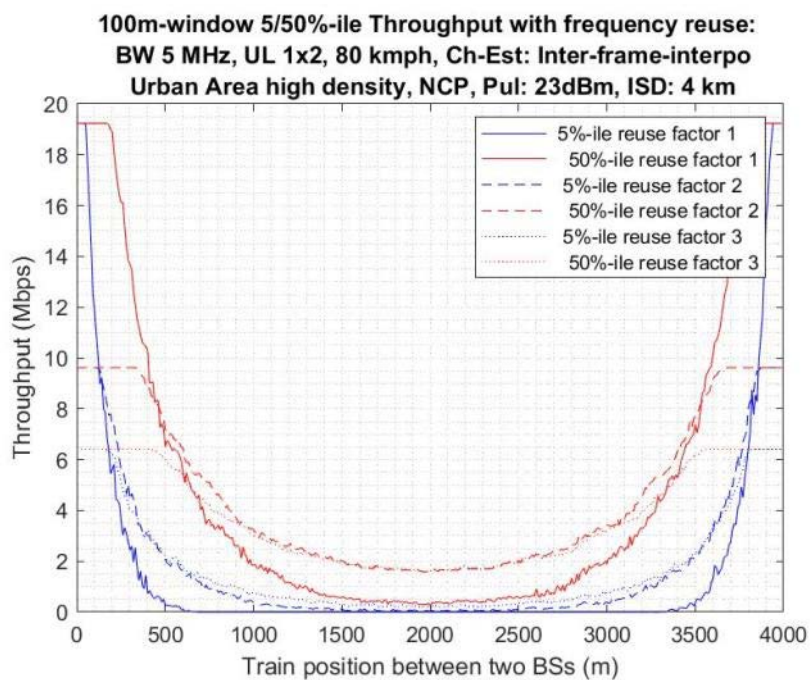

Figure B.109

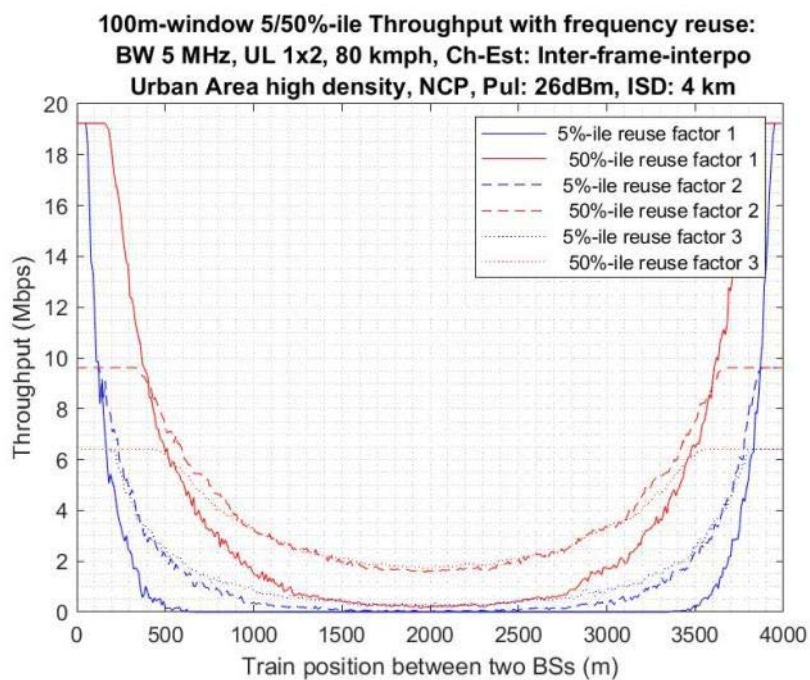

Figure B.110

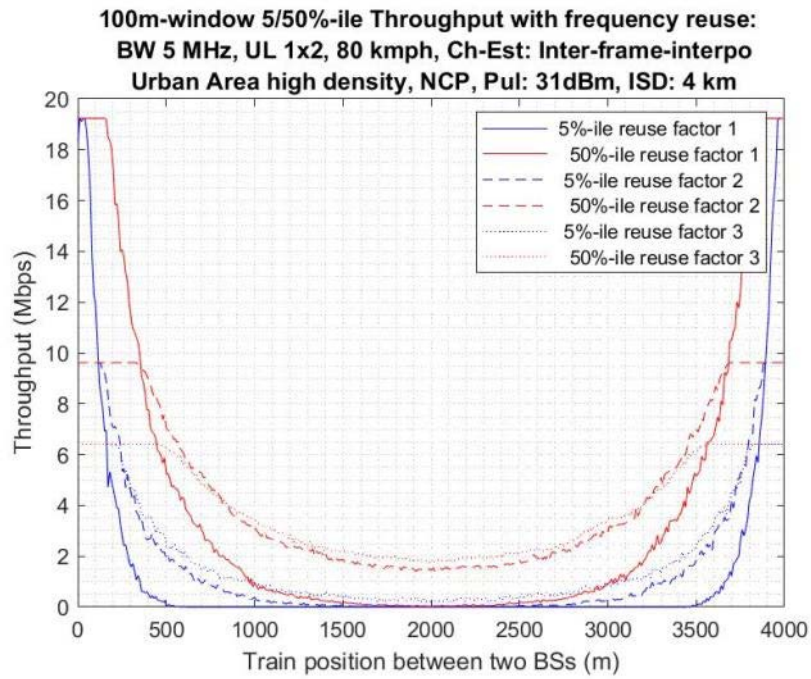

Figure B.111

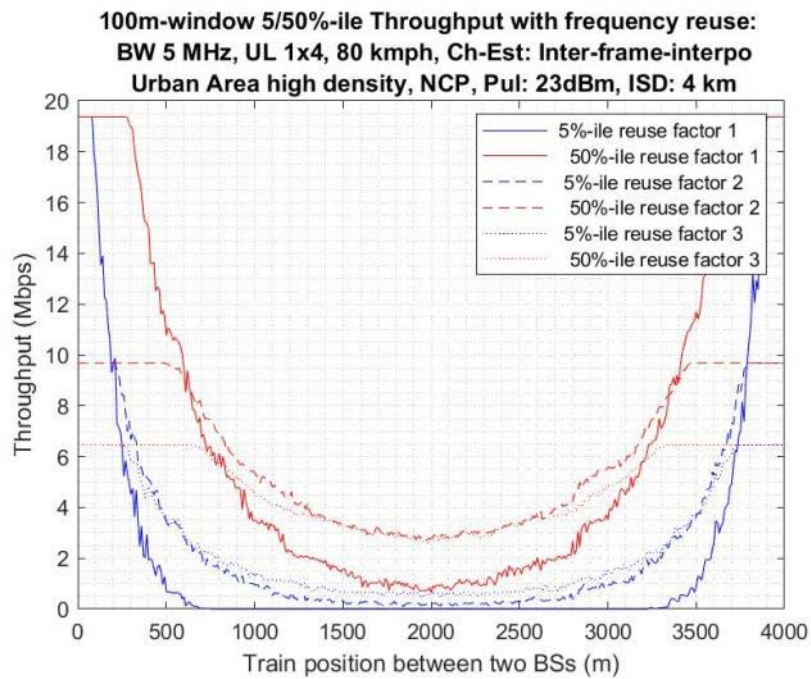

Figure B.112

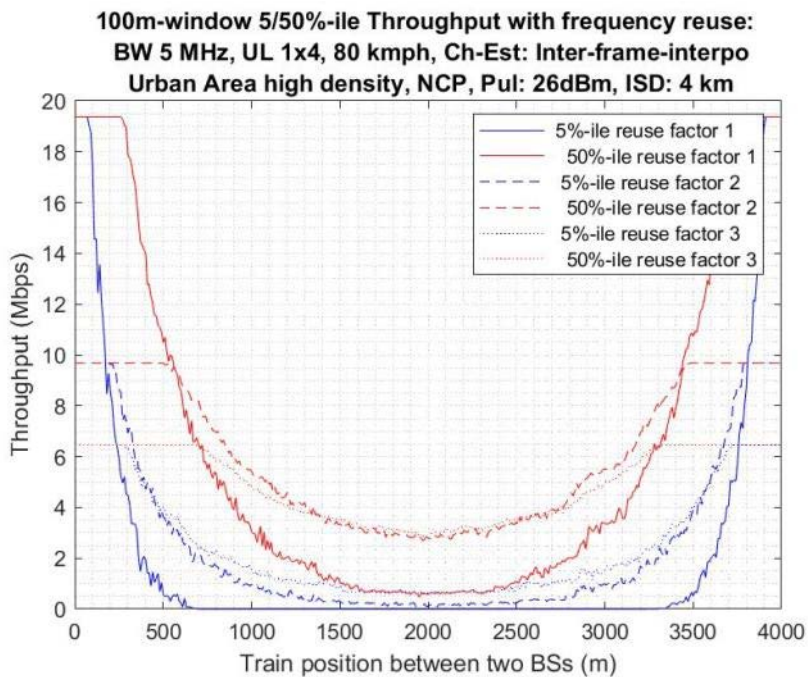

Figure B.113

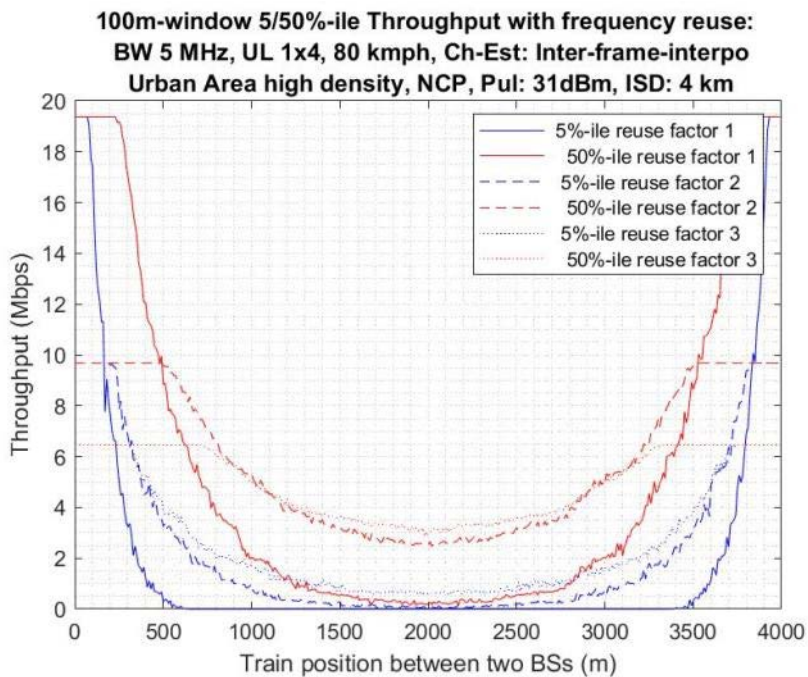

Figure B.114

Annex C: Data Throughput Measurements for results set 3

The following curves show UL throughput measurements obtained with the test bed described in clause 5.3.1, with UDP traffic using 1 024 bytes packet size.

LTE Channel Bandwidth = 3 MHz, Speed = 360 km/d Hilly Terrain with 6 taps

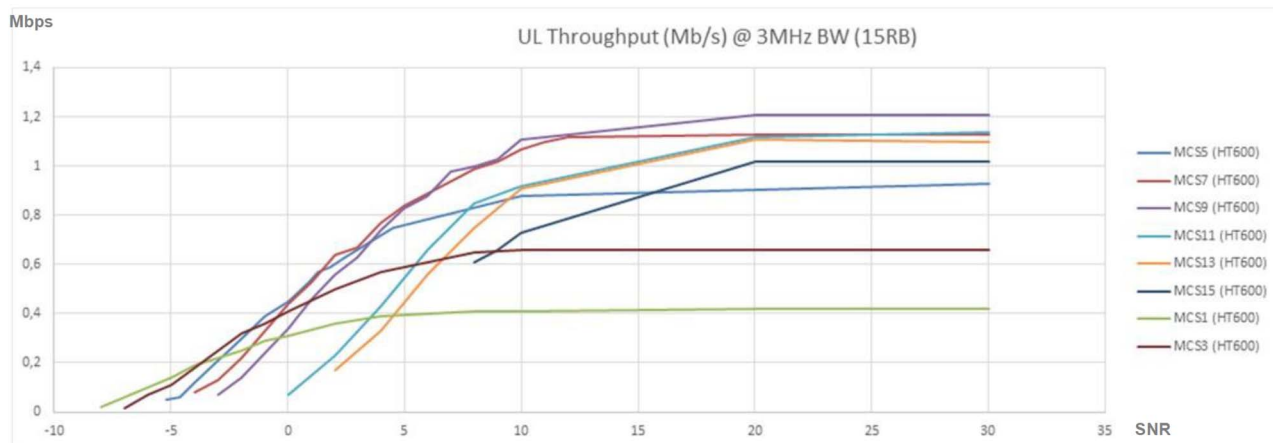

Figure C.1

LTE Channel Bandwidth = 3 MHz, Speed = 500 km/d Hilly Terrain with 6 taps

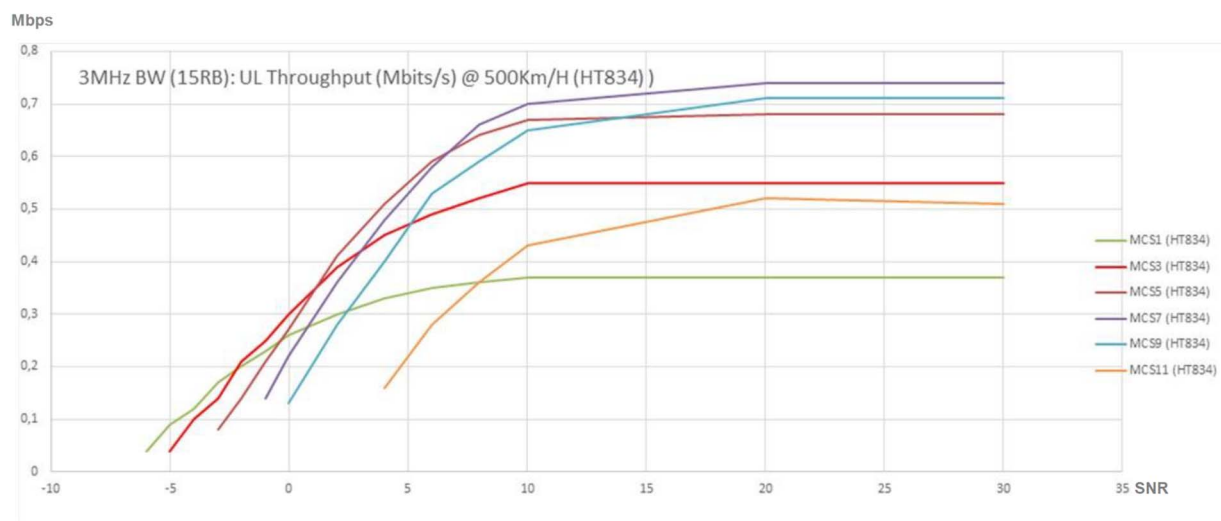

Figure C.2

LTE Channel Bandwidth = 1,4 MHz, Speed = 360 km/h Hilly Terrain with 6 taps

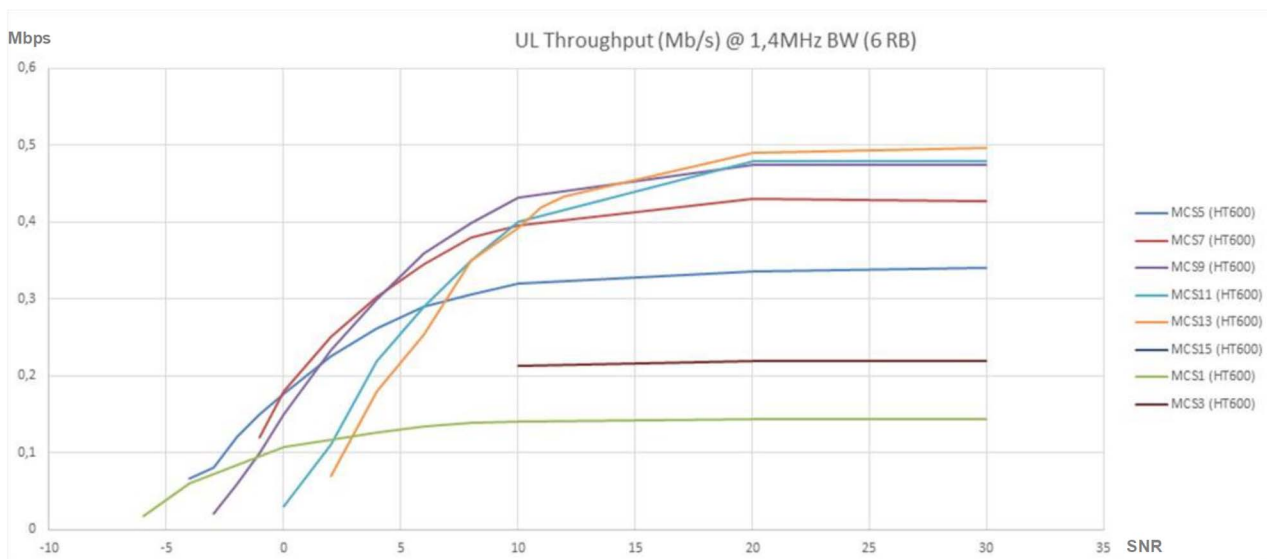

Figure C.3

Maximum data rate per MCS vs conditions (3 MHz)

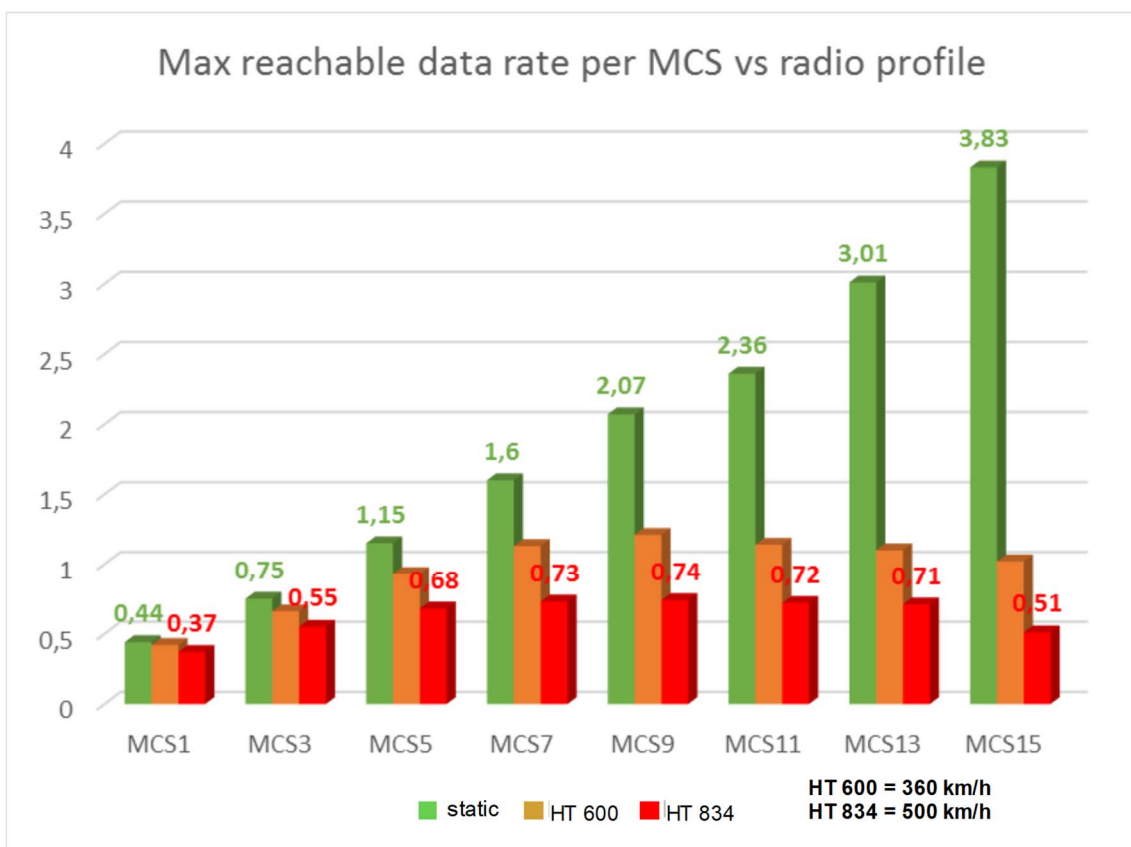

Figure C.4

Annex D: Antenna diagrams

Antenna diagram 1

| Gain (dB) | Horizontal aperture (°) | Vertical aperture (°) |
|-----------|-------------------------|-----------------------|
| 20,5 | 30 | 8,5 |

| Angle (°) | Attenuation (dB) | |
|-----------|------------------|----------|
| | Horizontal | Vertical |
| 0 | 0,00 | 0,00 |
| 1 | 0,02 | 0,18 |
| 2 | 0,06 | 0,71 |
| 3 | 0,13 | 1,61 |
| 4 | 0,23 | 2,92 |
| 5 | 0,35 | 4,67 |
| 6 | 0,50 | 6,97 |
| 7 | 0,67 | 9,99 |
| 8 | 0,87 | 14,07 |
| 9 | 1,10 | 20,09 |
| 10 | 1,35 | 28,71 |
| 11 | 1,63 | 24,72 |
| 12 | 1,94 | 20,96 |
| 13 | 2,28 | 19,66 |
| 14 | 2,64 | 19,85 |
| 15 | 3,04 | 21,32 |
| 16 | 3,47 | 24,29 |
| 17 | 3,94 | 28,98 |
| 18 | 4,45 | 29,38 |
| 19 | 5,01 | 24,68 |
| 20 | 5,62 | 21,56 |
| 21 | 6,29 | 19,86 |
| 22 | 7,02 | 19,20 |
| 23 | 7,81 | 19,42 |
| 24 | 8,67 | 20,50 |
| 25 | 9,60 | 22,54 |
| 26 | 10,61 | 25,71 |
| 27 | 11,70 | 29,83 |
| 28 | 12,89 | 31,65 |
| 29 | 14,22 | 29,83 |
| 30 | 15,71 | 28,58 |
| 31 | 17,43 | 28,86 |
| 32 | 19,50 | 30,69 |
| 33 | 22,00 | 33,28 |
| 34 | 25,02 | 32,18 |
| 35 | 28,06 | 28,39 |
| 36 | 28,67 | 25,48 |
| 37 | 26,40 | 23,63 |
| 38 | 23,87 | 22,58 |
| 39 | 21,82 | 22,16 |
| 40 | 20,23 | 22,27 |
| 41 | 18,98 | 22,86 |
| 42 | 17,95 | 23,91 |
| 43 | 17,09 | 25,47 |
| 44 | 16,36 | 27,64 |
| 45 | 15,75 | 30,53 |
| 46 | 15,21 | 33,85 |
| 47 | 14,76 | 35,28 |
| 48 | 14,39 | 33,44 |

| Angle (°) | Attenuation (dB) | |
|-----------|------------------|----------|
| | Horizontal | Vertical |
| 49 | 14,08 | 31,29 |
| 50 | 13,84 | 29,93 |
| 51 | 13,65 | 29,34 |
| 52 | 13,52 | 29,44 |
| 53 | 13,42 | 30,19 |
| 54 | 13,35 | 31,63 |
| 55 | 13,32 | 33,93 |
| 56 | 13,31 | 37,62 |
| 57 | 13,32 | 44,70 |
| 58 | 13,36 | 54,87 |
| 59 | 13,41 | 41,09 |
| 60 | 13,49 | 36,15 |
| 61 | 13,59 | 33,23 |
| 62 | 13,71 | 31,24 |
| 63 | 13,84 | 29,81 |
| 64 | 13,98 | 28,77 |
| 65 | 14,14 | 28,04 |
| 66 | 14,32 | 27,54 |
| 67 | 14,51 | 27,23 |
| 68 | 14,71 | 27,07 |
| 69 | 14,93 | 27,04 |
| 70 | 15,17 | 27,11 |
| 71 | 15,41 | 27,28 |
| 72 | 15,66 | 27,56 |
| 73 | 15,93 | 27,95 |
| 74 | 16,19 | 28,43 |
| 75 | 16,46 | 28,99 |
| 76 | 16,74 | 29,57 |
| 77 | 17,02 | 30,11 |
| 78 | 17,31 | 30,55 |
| 79 | 17,60 | 30,85 |
| 80 | 17,90 | 31,04 |
| 81 | 18,21 | 31,16 |
| 82 | 18,52 | 31,27 |
| 83 | 18,83 | 31,42 |
| 84 | 19,14 | 31,64 |
| 85 | 19,44 | 31,94 |
| 86 | 19,75 | 32,30 |
| 87 | 20,06 | 32,71 |
| 88 | 20,37 | 33,16 |
| 89 | 20,68 | 33,64 |
| 90 | 20,99 | 34,14 |
| 91 | 21,31 | 34,66 |
| 92 | 21,64 | 35,14 |
| 93 | 21,96 | 35,55 |
| 94 | 22,29 | 35,88 |
| 95 | 22,63 | 36,16 |
| 96 | 22,96 | 36,50 |
| 97 | 23,29 | 37,03 |
| 98 | 23,62 | 37,90 |
| 99 | 23,94 | 39,27 |
| 100 | 24,25 | 41,27 |
| 101 | 24,55 | 43,83 |
| 102 | 24,84 | 45,94 |
| 103 | 25,12 | 45,82 |
| 104 | 25,39 | 44,50 |
| 105 | 25,66 | 43,70 |

| Angle (°) | Attenuation (dB) | |
|-----------|------------------|----------|
| | Horizontal | Vertical |
| 106 | 25,93 | 43,81 |
| 107 | 26,18 | 44,61 |
| 108 | 26,44 | 45,20 |
| 109 | 26,69 | 44,40 |
| 110 | 26,93 | 42,65 |
| 111 | 27,18 | 41,08 |
| 112 | 27,41 | 40,07 |
| 113 | 27,62 | 39,61 |
| 114 | 27,82 | 39,55 |
| 115 | 27,99 | 39,67 |
| 116 | 28,13 | 39,71 |
| 117 | 28,23 | 39,45 |
| 118 | 28,33 | 38,82 |
| 119 | 28,41 | 37,91 |
| 120 | 28,50 | 36,93 |
| 121 | 28,59 | 36,07 |
| 122 | 28,72 | 35,47 |
| 123 | 28,86 | 35,19 |
| 124 | 29,00 | 35,25 |
| 125 | 29,12 | 35,60 |
| 126 | 29,23 | 36,12 |
| 127 | 29,29 | 36,64 |
| 128 | 29,33 | 37,00 |
| 129 | 29,36 | 37,14 |
| 130 | 29,41 | 37,11 |
| 131 | 29,50 | 37,01 |
| 132 | 29,63 | 36,90 |
| 133 | 29,82 | 36,80 |
| 134 | 30,06 | 36,80 |
| 135 | 30,33 | 36,97 |
| 136 | 30,60 | 37,39 |
| 137 | 30,87 | 38,05 |
| 138 | 31,14 | 38,79 |
| 139 | 31,40 | 39,16 |
| 140 | 31,67 | 38,74 |
| 141 | 31,99 | 37,64 |
| 142 | 32,39 | 36,40 |
| 143 | 32,85 | 35,40 |
| 144 | 33,39 | 34,79 |
| 145 | 33,98 | 34,64 |
| 146 | 34,59 | 34,96 |
| 147 | 35,16 | 35,78 |
| 148 | 35,68 | 37,03 |
| 149 | 36,13 | 38,53 |
| 150 | 36,50 | 39,91 |
| 151 | 36,79 | 40,82 |
| 152 | 37,02 | 41,44 |
| 153 | 37,21 | 42,30 |
| 154 | 37,29 | 43,65 |
| 155 | 37,25 | 44,69 |
| 156 | 37,08 | 43,97 |
| 157 | 36,79 | 42,25 |
| 158 | 36,40 | 40,97 |
| 159 | 35,97 | 40,42 |
| 160 | 35,51 | 40,23 |
| 161 | 35,07 | 39,65 |
| 162 | 34,65 | 38,45 |

| Angle (°) | Attenuation (dB) | |
|-----------|------------------|----------|
| | Horizontal | Vertical |
| 163 | 34,28 | 37,21 |
| 164 | 33,96 | 36,56 |
| 165 | 33,69 | 36,78 |
| 166 | 33,47 | 38,09 |
| 167 | 33,31 | 40,75 |
| 168 | 33,19 | 45,28 |
| 169 | 33,10 | 51,94 |
| 170 | 33,03 | 54,18 |
| 171 | 32,98 | 53,77 |
| 172 | 32,95 | 52,67 |
| 173 | 32,94 | 45,92 |
| 174 | 32,98 | 40,70 |
| 175 | 33,07 | 37,39 |
| 176 | 33,23 | 35,42 |
| 177 | 33,44 | 34,46 |
| 178 | 33,70 | 34,36 |
| 179 | 34,01 | 35,06 |
| 180 | 34,37 | 36,55 |
| 181 | 34,69 | 38,89 |
| 182 | 34,99 | 42,00 |
| 183 | 35,26 | 44,68 |
| 184 | 35,51 | 44,51 |
| 185 | 35,77 | 42,92 |
| 186 | 36,07 | 41,89 |
| 187 | 36,42 | 41,66 |
| 188 | 36,83 | 42,03 |
| 189 | 37,29 | 42,62 |
| 190 | 37,82 | 42,97 |
| 191 | 38,38 | 42,72 |
| 192 | 38,94 | 41,75 |
| 193 | 39,49 | 40,32 |
| 194 | 40,03 | 38,82 |
| 195 | 40,49 | 37,64 |
| 196 | 40,89 | 37,01 |
| 197 | 41,21 | 37,02 |
| 198 | 41,46 | 37,68 |
| 199 | 41,63 | 38,78 |
| 200 | 41,75 | 39,62 |
| 201 | 41,82 | 39,26 |
| 202 | 41,81 | 37,84 |
| 203 | 41,69 | 36,27 |
| 204 | 41,45 | 35,01 |
| 205 | 41,10 | 34,18 |
| 206 | 40,62 | 33,83 |
| 207 | 40,08 | 34,01 |
| 208 | 39,56 | 34,78 |
| 209 | 39,12 | 36,18 |
| 210 | 38,74 | 37,94 |
| 211 | 38,42 | 38,99 |
| 212 | 38,21 | 38,26 |
| 213 | 38,02 | 36,75 |
| 214 | 37,82 | 35,65 |
| 215 | 37,57 | 35,28 |
| 216 | 37,30 | 35,72 |
| 217 | 37,01 | 37,03 |
| 218 | 36,70 | 39,37 |
| 219 | 36,43 | 43,20 |
| 220 | 36,24 | 49,56 |
| 221 | 36,13 | 52,60 |
| 222 | 36,07 | 46,94 |
| 223 | 36,09 | 43,92 |
| 224 | 36,14 | 42,66 |

| Angle (°) | Attenuation (dB) | |
|-----------|------------------|----------|
| | Horizontal | Vertical |
| 225 | 36,20 | 42,58 |
| 226 | 36,19 | 43,58 |
| 227 | 36,16 | 45,92 |
| 228 | 36,10 | 50,69 |
| 229 | 36,00 | 63,80 |
| 230 | 35,89 | 52,12 |
| 231 | 35,80 | 45,70 |
| 232 | 35,75 | 42,16 |
| 233 | 35,70 | 39,85 |
| 234 | 35,64 | 38,25 |
| 235 | 35,56 | 37,16 |
| 236 | 35,45 | 36,49 |
| 237 | 35,27 | 36,21 |
| 238 | 35,04 | 36,32 |
| 239 | 34,80 | 36,88 |
| 240 | 34,55 | 37,93 |
| 241 | 34,30 | 39,62 |
| 242 | 34,05 | 42,15 |
| 243 | 33,82 | 45,75 |
| 244 | 33,57 | 48,75 |
| 245 | 33,28 | 46,31 |
| 246 | 32,93 | 42,68 |
| 247 | 32,55 | 40,03 |
| 248 | 32,12 | 38,15 |
| 249 | 31,64 | 36,75 |
| 250 | 31,16 | 35,64 |
| 251 | 30,68 | 34,73 |
| 252 | 30,23 | 33,95 |
| 253 | 29,79 | 33,29 |
| 254 | 29,39 | 32,72 |
| 255 | 29,00 | 32,24 |
| 256 | 28,61 | 31,85 |
| 257 | 28,21 | 31,55 |
| 258 | 27,80 | 31,32 |
| 259 | 27,37 | 31,13 |
| 260 | 26,93 | 30,95 |
| 261 | 26,47 | 30,74 |
| 262 | 26,02 | 30,46 |
| 263 | 25,58 | 30,12 |
| 264 | 25,14 | 29,73 |
| 265 | 24,72 | 29,32 |
| 266 | 24,31 | 28,92 |
| 267 | 23,91 | 28,55 |
| 268 | 23,50 | 28,21 |
| 269 | 23,10 | 27,88 |
| 270 | 22,69 | 27,53 |
| 271 | 22,27 | 27,12 |
| 272 | 21,85 | 26,65 |
| 273 | 21,44 | 26,10 |
| 274 | 21,03 | 25,50 |
| 275 | 20,64 | 24,88 |
| 276 | 20,25 | 24,28 |
| 277 | 19,86 | 23,70 |
| 278 | 19,49 | 23,17 |
| 279 | 19,11 | 22,67 |
| 280 | 18,73 | 22,18 |
| 281 | 18,36 | 21,69 |
| 282 | 17,99 | 21,17 |
| 283 | 17,63 | 20,64 |
| 284 | 17,27 | 20,11 |
| 285 | 16,94 | 19,60 |
| 286 | 16,61 | 19,13 |

| Angle (°) | Attenuation (dB) | |
|-----------|------------------|----------|
| | Horizontal | Vertical |
| 287 | 16,30 | 18,75 |
| 288 | 16,00 | 18,45 |
| 289 | 15,71 | 18,26 |
| 290 | 15,43 | 18,18 |
| 291 | 15,16 | 18,20 |
| 292 | 14,90 | 18,31 |
| 293 | 14,65 | 18,53 |
| 294 | 14,42 | 18,84 |
| 295 | 14,21 | 19,26 |
| 296 | 14,01 | 19,81 |
| 297 | 13,84 | 20,52 |
| 298 | 13,68 | 21,46 |
| 299 | 13,54 | 22,69 |
| 300 | 13,41 | 24,33 |
| 301 | 13,31 | 26,55 |
| 302 | 13,23 | 29,66 |
| 303 | 13,18 | 34,20 |
| 304 | 13,16 | 39,46 |
| 305 | 13,17 | 36,84 |
| 306 | 13,21 | 32,77 |
| 307 | 13,29 | 30,38 |
| 308 | 13,40 | 29,14 |
| 309 | 13,55 | 28,77 |
| 310 | 13,74 | 29,20 |
| 311 | 13,98 | 30,56 |
| 312 | 14,28 | 33,27 |
| 313 | 14,64 | 38,04 |
| 314 | 15,07 | 38,24 |
| 315 | 15,59 | 31,93 |
| 316 | 16,21 | 27,63 |
| 317 | 16,95 | 24,76 |
| 318 | 17,82 | 22,82 |
| 319 | 18,85 | 21,56 |
| 320 | 20,07 | 20,88 |
| 321 | 21,50 | 20,71 |
| 322 | 23,07 | 21,07 |
| 323 | 24,41 | 22,00 |
| 324 | 24,74 | 23,60 |
| 325 | 23,53 | 26,11 |
| 326 | 21,49 | 29,88 |
| 327 | 19,34 | 34,05 |
| 328 | 17,39 | 32,37 |
| 329 | 15,68 | 28,71 |
| 330 | 14,18 | 26,42 |
| 331 | 12,86 | 25,22 |
| 332 | 11,68 | 24,66 |
| 333 | 10,62 | 24,22 |
| 334 | 9,65 | 23,32 |
| 335 | 8,75 | 21,83 |
| 336 | 7,92 | 20,17 |
| 337 | 7,15 | 18,79 |
| 338 | 6,43 | 17,90 |
| 339 | 5,76 | 17,61 |
| 340 | 5,15 | 18,02 |
| 341 | 4,58 | 19,27 |
| 342 | 4,06 | 21,67 |
| 343 | 3,58 | 25,81 |
| 344 | 3,14 | 30,26 |
| 345 | 2,74 | 26,59 |
| 346 | 2,36 | 22,83 |
| 347 | 2,02 | 21,14 |
| 348 | 1,70 | 21,28 |

| Angle (°) | Attenuation (dB) | |
|-----------|------------------|----------|
| | Horizontal | Vertical |
| 349 | 1,41 | 23,52 |
| 350 | 1,15 | 26,23 |
| 351 | 0,92 | 20,27 |
| 352 | 0,72 | 14,32 |
| 353 | 0,54 | 10,12 |
| 354 | 0,39 | 7,03 |
| 355 | 0,26 | 4,68 |
| 356 | 0,16 | 2,91 |
| 357 | 0,09 | 1,60 |
| 358 | 0,03 | 0,70 |
| 359 | 0,01 | 0,17 |

Antenna diagram 2

| Gain (dB) | Horizontal aperture (°) | Vertical aperture (°) |
|-----------|-------------------------|-----------------------|
| 18 | 65 | 7 |

| Angle (°) | Attenuation (dB) | |
|-----------|------------------|----------|
| | Horizontal | Vertical |
| 0 | 0,00 | 0,00 |
| 1 | 0,01 | 0,11 |
| 2 | 0,03 | 0,65 |
| 3 | 0,05 | 1,62 |
| 4 | 0,08 | 3,07 |
| 5 | 0,11 | 5,06 |
| 6 | 0,16 | 7,70 |
| 7 | 0,20 | 11,20 |
| 8 | 0,26 | 15,97 |
| 9 | 0,32 | 22,93 |
| 10 | 0,39 | 30,72 |
| 11 | 0,46 | 27,23 |
| 12 | 0,54 | 25,52 |
| 13 | 0,63 | 26,17 |
| 14 | 0,72 | 28,30 |
| 15 | 0,82 | 30,81 |
| 16 | 0,93 | 32,21 |
| 17 | 1,04 | 33,26 |
| 18 | 1,16 | 36,50 |
| 19 | 1,28 | 50,77 |
| 20 | 1,41 | 37,04 |
| 21 | 1,55 | 29,94 |
| 22 | 1,69 | 26,41 |
| 23 | 1,84 | 24,53 |
| 24 | 1,99 | 23,77 |
| 25 | 2,15 | 23,90 |
| 26 | 2,32 | 24,79 |
| 27 | 2,49 | 26,22 |
| 28 | 2,66 | 27,42 |
| 29 | 2,84 | 27,21 |
| 30 | 3,03 | 25,80 |
| 31 | 3,22 | 24,35 |
| 32 | 3,42 | 23,42 |
| 33 | 3,62 | 23,15 |
| 34 | 3,83 | 23,61 |
| 35 | 4,04 | 24,91 |
| 36 | 4,26 | 27,37 |
| 37 | 4,48 | 31,82 |
| 38 | 4,71 | 41,04 |
| 39 | 4,94 | 36,20 |
| 40 | 5,18 | 29,97 |
| 41 | 5,42 | 26,89 |
| 42 | 5,66 | 25,24 |
| 43 | 5,92 | 24,48 |
| 44 | 6,17 | 24,37 |
| 45 | 6,43 | 24,80 |
| 46 | 6,69 | 25,75 |
| 47 | 6,96 | 27,30 |
| 48 | 7,23 | 29,69 |
| 49 | 7,51 | 33,58 |
| 50 | 7,79 | 41,09 |
| 51 | 8,07 | 40,56 |
| 52 | 8,36 | 33,05 |
| 53 | 8,64 | 29,12 |

| Angle (°) | Attenuation (dB) | |
|-----------|------------------|----------|
| | Horizontal | Vertical |
| 54 | 8,94 | 26,80 |
| 55 | 9,23 | 25,45 |
| 56 | 9,53 | 24,82 |
| 57 | 9,83 | 24,80 |
| 58 | 10,13 | 25,30 |
| 59 | 10,44 | 26,24 |
| 60 | 10,75 | 27,43 |
| 61 | 11,05 | 28,49 |
| 62 | 11,37 | 28,93 |
| 63 | 11,68 | 28,67 |
| 64 | 11,99 | 28,17 |
| 65 | 12,30 | 27,88 |
| 66 | 12,61 | 28,03 |
| 67 | 12,92 | 28,73 |
| 68 | 13,23 | 30,08 |
| 69 | 13,54 | 32,22 |
| 70 | 13,85 | 35,42 |
| 71 | 14,16 | 39,80 |
| 72 | 14,47 | 42,13 |
| 73 | 14,78 | 38,87 |
| 74 | 15,09 | 35,76 |
| 75 | 15,40 | 33,74 |
| 76 | 15,70 | 32,52 |
| 77 | 16,01 | 31,88 |
| 78 | 16,31 | 31,70 |
| 79 | 16,62 | 31,92 |
| 80 | 16,92 | 32,51 |
| 81 | 17,22 | 33,43 |
| 82 | 17,53 | 34,66 |
| 83 | 17,82 | 36,16 |
| 84 | 18,13 | 37,94 |
| 85 | 18,43 | 39,94 |
| 86 | 18,74 | 42,13 |
| 87 | 19,05 | 44,41 |
| 88 | 19,37 | 46,64 |
| 89 | 19,69 | 48,58 |
| 90 | 20,00 | 49,91 |
| 91 | 20,33 | 50,59 |
| 92 | 20,66 | 50,97 |
| 93 | 20,99 | 51,13 |
| 94 | 21,33 | 50,27 |
| 95 | 21,67 | 47,87 |
| 96 | 22,02 | 44,88 |
| 97 | 22,37 | 42,14 |
| 98 | 22,73 | 39,85 |
| 99 | 23,09 | 38,02 |
| 100 | 23,47 | 36,62 |
| 101 | 23,85 | 35,65 |
| 102 | 24,23 | 35,09 |
| 103 | 24,62 | 34,94 |
| 104 | 25,02 | 35,15 |
| 105 | 25,43 | 35,66 |
| 106 | 25,84 | 36,36 |
| 107 | 26,27 | 37,15 |
| 108 | 26,70 | 37,93 |
| 109 | 27,14 | 38,59 |
| 110 | 27,58 | 39,00 |
| 111 | 28,04 | 39,01 |
| 112 | 28,50 | 38,73 |
| 113 | 28,97 | 38,51 |
| 114 | 29,45 | 38,73 |
| 115 | 29,94 | 39,72 |

| Angle (°) | Attenuation (dB) | |
|-----------|------------------|----------|
| | Horizontal | Vertical |
| 116 | 30,44 | 41,92 |
| 117 | 30,94 | 46,14 |
| 118 | 31,46 | 52,67 |
| 119 | 31,98 | 47,93 |
| 120 | 32,51 | 43,10 |
| 121 | 33,05 | 40,73 |
| 122 | 33,60 | 39,87 |
| 123 | 34,16 | 40,21 |
| 124 | 34,73 | 41,63 |
| 125 | 35,30 | 43,91 |
| 126 | 35,88 | 45,44 |
| 127 | 36,47 | 44,12 |
| 128 | 37,06 | 42,03 |
| 129 | 37,66 | 40,76 |
| 130 | 38,26 | 40,46 |
| 131 | 38,86 | 40,91 |
| 132 | 39,47 | 41,50 |
| 133 | 40,08 | 41,19 |
| 134 | 40,69 | 39,79 |
| 135 | 41,31 | 38,26 |
| 136 | 41,92 | 37,28 |
| 137 | 42,55 | 37,09 |
| 138 | 43,19 | 37,85 |
| 139 | 43,85 | 39,82 |
| 140 | 44,55 | 43,77 |
| 141 | 45,27 | 52,41 |
| 142 | 46,09 | 50,00 |
| 143 | 46,98 | 43,21 |
| 144 | 48,00 | 40,22 |
| 145 | 49,18 | 39,01 |
| 146 | 50,62 | 39,05 |
| 147 | 52,47 | 40,24 |
| 148 | 54,91 | 42,78 |
| 149 | 58,51 | 47,45 |
| 150 | 65,46 | 56,50 |
| 151 | 75,75 | 52,14 |
| 152 | 61,12 | 46,68 |
| 153 | 55,72 | 44,30 |
| 154 | 52,28 | 43,49 |
| 155 | 49,73 | 43,83 |
| 156 | 47,69 | 45,16 |
| 157 | 45,99 | 47,52 |
| 158 | 44,52 | 50,88 |
| 159 | 43,24 | 55,04 |
| 160 | 42,10 | 59,93 |
| 161 | 41,08 | 71,69 |
| 162 | 40,16 | 61,44 |
| 163 | 39,32 | 52,80 |
| 164 | 38,55 | 48,12 |
| 165 | 37,85 | 45,12 |
| 166 | 37,21 | 43,04 |
| 167 | 36,63 | 41,43 |
| 168 | 36,09 | 39,98 |
| 169 | 35,60 | 38,55 |
| 170 | 35,14 | 37,21 |
| 171 | 34,74 | 36,02 |
| 172 | 34,37 | 35,06 |
| 173 | 34,04 | 34,34 |
| 174 | 33,74 | 33,80 |
| 175 | 33,48 | 33,40 |
| 176 | 33,25 | 33,08 |
| 177 | 33,06 | 32,83 |

| Angle (°) | Attenuation (dB) | |
|-----------|------------------|----------|
| | Horizontal | Vertical |
| 178 | 32,89 | 32,63 |
| 179 | 32,76 | 32,50 |
| 180 | 32,66 | 32,67 |
| 181 | 32,59 | 33,11 |
| 182 | 32,55 | 33,92 |
| 183 | 32,54 | 35,26 |
| 184 | 32,57 | 37,35 |
| 185 | 32,62 | 40,50 |
| 186 | 32,71 | 44,84 |
| 187 | 32,83 | 46,66 |
| 188 | 32,98 | 43,72 |
| 189 | 33,16 | 41,58 |
| 190 | 33,38 | 41,00 |
| 191 | 33,64 | 41,89 |
| 192 | 33,93 | 44,27 |
| 193 | 34,26 | 47,53 |
| 194 | 34,64 | 47,71 |
| 195 | 35,06 | 45,30 |
| 196 | 35,52 | 44,10 |
| 197 | 36,04 | 44,68 |
| 198 | 36,61 | 46,99 |
| 199 | 37,25 | 48,69 |
| 200 | 37,95 | 45,65 |
| 201 | 38,73 | 42,45 |
| 202 | 39,61 | 40,79 |
| 203 | 40,58 | 40,54 |
| 204 | 41,69 | 41,65 |
| 205 | 42,95 | 44,30 |
| 206 | 44,41 | 48,42 |
| 207 | 46,13 | 49,81 |
| 208 | 48,22 | 46,65 |
| 209 | 50,81 | 44,51 |
| 210 | 54,04 | 43,86 |
| 211 | 57,37 | 44,43 |
| 212 | 57,37 | 46,13 |
| 213 | 54,23 | 49,09 |
| 214 | 51,28 | 53,95 |
| 215 | 48,96 | 63,25 |
| 216 | 47,12 | 61,64 |
| 217 | 45,66 | 54,87 |
| 218 | 44,42 | 51,23 |
| 219 | 43,39 | 48,50 |
| 220 | 42,48 | 46,11 |
| 221 | 41,69 | 44,08 |
| 222 | 40,98 | 42,54 |
| 223 | 40,34 | 41,56 |
| 224 | 39,75 | 41,19 |
| 225 | 39,21 | 41,43 |
| 226 | 38,71 | 42,28 |
| 227 | 38,23 | 43,76 |
| 228 | 37,78 | 45,93 |
| 229 | 37,34 | 48,89 |
| 230 | 36,91 | 52,95 |
| 231 | 36,49 | 59,13 |
| 232 | 36,07 | 71,04 |
| 233 | 35,65 | 59,51 |
| 234 | 35,24 | 52,97 |
| 235 | 34,81 | 48,88 |
| 236 | 34,39 | 46,11 |
| 237 | 33,95 | 44,36 |
| 238 | 33,51 | 43,53 |
| 239 | 33,07 | 43,56 |

| Angle (°) | Attenuation (dB) | |
|-----------|------------------|----------|
| | Horizontal | Vertical |
| 240 | 32,62 | 44,42 |
| 241 | 32,16 | 46,03 |
| 242 | 31,69 | 48,14 |
| 243 | 31,22 | 50,14 |
| 244 | 30,74 | 51,42 |
| 245 | 30,27 | 52,10 |
| 246 | 29,79 | 52,28 |
| 247 | 29,30 | 51,68 |
| 248 | 28,82 | 50,50 |
| 249 | 28,33 | 49,29 |
| 250 | 27,85 | 48,21 |
| 251 | 27,37 | 47,21 |
| 252 | 26,89 | 46,47 |
| 253 | 26,42 | 46,41 |
| 254 | 25,96 | 47,57 |
| 255 | 25,49 | 50,26 |
| 256 | 25,04 | 50,79 |
| 257 | 24,59 | 46,07 |
| 258 | 24,15 | 42,22 |
| 259 | 23,71 | 39,90 |
| 260 | 23,29 | 38,69 |
| 261 | 22,87 | 38,23 |
| 262 | 22,46 | 38,04 |
| 263 | 22,06 | 37,66 |
| 264 | 21,66 | 36,98 |
| 265 | 21,28 | 36,35 |
| 266 | 20,90 | 36,16 |
| 267 | 20,53 | 36,64 |
| 268 | 20,16 | 37,90 |
| 269 | 19,80 | 40,00 |
| 270 | 19,45 | 40,00 |
| 271 | 19,11 | 42,80 |
| 272 | 18,77 | 45,77 |
| 273 | 18,44 | 47,75 |
| 274 | 18,11 | 47,89 |
| 275 | 17,78 | 46,29 |
| 276 | 17,47 | 44,02 |
| 277 | 17,15 | 42,12 |
| 278 | 16,84 | 41,02 |
| 279 | 16,53 | 40,73 |
| 280 | 16,22 | 40,99 |
| 281 | 15,91 | 41,21 |
| 282 | 15,60 | 40,81 |
| 283 | 15,30 | 39,95 |
| 284 | 14,99 | 39,33 |
| 285 | 14,69 | 39,39 |
| 286 | 14,38 | 40,33 |
| 287 | 14,08 | 42,21 |
| 288 | 13,78 | 44,26 |
| 289 | 13,47 | 44,00 |
| 290 | 13,17 | 41,60 |
| 291 | 12,86 | 39,42 |
| 292 | 12,56 | 38,00 |
| 293 | 12,26 | 37,24 |
| 294 | 11,95 | 36,95 |
| 295 | 11,65 | 36,91 |
| 296 | 11,35 | 36,82 |
| 297 | 11,05 | 36,43 |
| 298 | 10,75 | 35,69 |
| 299 | 10,45 | 34,76 |
| 300 | 10,15 | 33,84 |
| 301 | 9,86 | 33,10 |

| Angle (°) | Attenuation (dB) | |
|-----------|------------------|----------|
| | Horizontal | Vertical |
| 302 | 9,56 | 32,63 |
| 303 | 9,27 | 32,49 |
| 304 | 8,98 | 32,75 |
| 305 | 8,69 | 33,51 |
| 306 | 8,41 | 35,01 |
| 307 | 8,13 | 37,76 |
| 308 | 7,85 | 43,42 |
| 309 | 7,58 | 51,99 |
| 310 | 7,31 | 39,80 |
| 311 | 7,04 | 34,33 |
| 312 | 6,77 | 31,11 |
| 313 | 6,51 | 29,06 |
| 314 | 6,26 | 27,84 |
| 315 | 6,00 | 27,32 |
| 316 | 5,76 | 27,48 |
| 317 | 5,51 | 28,38 |
| 318 | 5,27 | 30,13 |
| 319 | 5,03 | 32,61 |
| 320 | 4,80 | 33,67 |
| 321 | 4,58 | 31,01 |
| 322 | 4,35 | 27,82 |
| 323 | 4,14 | 25,52 |
| 324 | 3,92 | 24,15 |
| 325 | 3,72 | 23,62 |
| 326 | 3,51 | 23,97 |
| 327 | 3,31 | 25,37 |
| 328 | 3,12 | 28,35 |
| 329 | 2,93 | 34,72 |
| 330 | 2,75 | 39,41 |
| 331 | 2,57 | 30,01 |
| 332 | 2,40 | 25,74 |
| 333 | 2,23 | 23,56 |
| 334 | 2,07 | 22,65 |
| 335 | 1,91 | 22,72 |
| 336 | 1,76 | 23,58 |
| 337 | 1,62 | 24,80 |
| 338 | 1,48 | 25,14 |
| 339 | 1,35 | 23,90 |
| 340 | 1,22 | 22,24 |
| 341 | 1,10 | 21,23 |
| 342 | 0,98 | 21,25 |
| 343 | 0,88 | 22,68 |
| 344 | 0,77 | 26,42 |
| 345 | 0,68 | 33,70 |
| 346 | 0,59 | 26,85 |
| 347 | 0,50 | 21,16 |
| 348 | 0,42 | 18,28 |
| 349 | 0,35 | 17,12 |
| 350 | 0,29 | 17,39 |
| 351 | 0,23 | 18,78 |
| 352 | 0,18 | 18,53 |
| 353 | 0,13 | 14,29 |
| 354 | 0,09 | 9,93 |
| 355 | 0,06 | 6,59 |
| 356 | 0,04 | 4,11 |
| 357 | 0,02 | 2,31 |
| 358 | 0,01 | 1,07 |
| 359 | 0,00 | 0,31 |

Annex E: Propagation models

The Hata model:

$$L_U = 69,55 + 26,16 \log_{10} f - 13,82 \log_{10} h_B - C_H + (44,9 - 6,55 \log_{10} h_B) \log_{10} d$$

For small or medium sized cities:

$$C_H = 0,8 + (1,1 \log_{10} f - 0,7) h_M - 1,56 \log_{10} f$$

For large cities:

$$C_H = 8,29 (\log_{10} (1.54 h_M))^2 - 1,1 \text{ if } 150 \leq f \leq 200$$

$$C_H = 3,29 (\log_{10} (11.75 h_M))^2 - 4,97 \text{ if } 200 \leq f \leq 15\,000$$

The Okumura-Hata model:

$$L_U = 69,55 + 26,16 \log_{10} f - 13,82 \log_{10} h_B - a(h_M) + (44,9 - 6,55 \log_{10} h_B) \log_{10} d + C_H$$

In open and urban areas:

$$a(h_M) = (1,1 (\log_{10} (f) - 0,7) h_M - (1,1 \log_{10} (f) - 0,8))$$

In urban areas:

$$C_H = 0$$

In rural areas:

$$C_H = -4,78 (\log_{10} (f))^2 + 18,33 \log_{10} (f) - 40,98$$

where:

L_U : path loss (dB)

h_B : base station antenna (m)

h_M : mobile station antenna height (m)

f : carrier frequency (MHz)

C_H : antenna height correction factor

d : distance between the base and mobile stations (km).

Table E.1: Application to scenarios of the present document

| Distance | Model | Scenario | | |
|----------------------|--------------------|----------|-------|--------------------------|
| | | Rural | Hilly | Urban/Urban High Density |
| Distance \leq 8 km | Okumura-Hata Rural | X | X | |
| | Okumura-Hata Urban | | | X |
| Distance \geq 8 km | Okumura-Hata Urban | | | X |

Annex F: Change history

| Date | Version | Information about changes |
|---------------|---------|---|
| July 2017 | 0.0.1 | Initial draft |
| December 2017 | 0.2.0 | Integration of agreements from July meeting and October review, integration of drafting sessions of November 2017 and December 2017 |
| January 2018 | 0.3.0 | Integration of RT #68 decisions |
| March 2018 | 0.4.0 | Integration of drafting session decisions: <ul style="list-style-type: none"> • LTE channel location • Results set 1 • Results set 3 |
| March 2018 | 0.5.0 | Added note and clarification on Worst Cell edge metric |
| April 2018 | 0.6.0 | Added section on comparison results |
| June 2018 | 0.7.0 | Interim conclusion with 1,4 MHz results |
| July 2018 | 0.9.2 | Clarifications on Fractional Frequency Reuse |
| January 2019 | 1.2.1 | Added results for 3 and 5 MHz bandwidth and added several UL Tx powers |
| March 2020 | 1.3.1 | 1 900 MHz results |

History

| Document history | | |
|-------------------------|---------------|--------------------------------|
| V1.1.1 | August 2018 | Publication as ETSI TR 103 554 |
| V1.2.1 | February 2019 | Publication |
| V1.3.1 | October 2020 | Publication |
| | | |
| | | |